

**Screw
Jacks**

UP SERIES

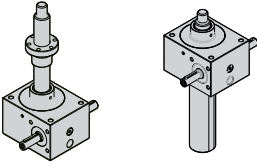
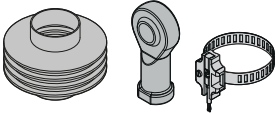
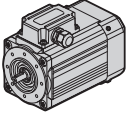

	Indice	<i>Index</i>	Index	Pag. Page Seite	
	A	Introduzione	<i>Introduction</i>	Einführung	A1
	B	Martinetti UP	<i>Screw jacks</i> UP	Hubgetriebe UP	B1
	C	Accessori	<i>Accessories</i>	Zubehör	C1
	D	Motori applicabili	<i>Applicable motors</i>	Anwendbare Motoren	D1

Questo catalogo annulla e sostituisce ogni precedente edizione o revisione.
Ci riserviamo inoltre il diritto di apportare modifiche senza preavviso.
La versione più aggiornata è disponibile sul sito
www.transtecno.com

*This catalogue supersedes any previous edition and revision.
We reserve the right to implement modifications without notice.
The most updated version is available on our website
www.transtecno.com*

Indice	Index	Index	Pag. Page Seite
Generalità	<i>General</i>	Allgemeine Informationen	A2
Simbologia	<i>Symbols used</i>	Symbole	A2
Definizione dei carichi	<i>Definition of loads</i>	Definition von Lasten	A2
Carichi massimi ammessi	<i>Maximum permissible loads</i>	Maximal zulässige Lasten	A3
Coppie in ingresso ai martinetti	<i>Jack input torque</i>	Eingangsdrehmoment des Hubgetriebes	A4
Velocità di sollevamento	<i>Lifting speed</i>	Hebegeschwindigkeit	A5
Corsa	<i>Stroke</i>	Hub	A5
Lubrificazione	<i>Lubrication</i>	Schmierung	A6
Temperatura di funzionamento e fattore di servizio	<i>Operating temperature and service factor</i>	Betriebstemperatur und Betriebsfaktor	A6
Formule di calcolo	<i>Calculation formulas</i>	Formeln für die Berechnung	A7
Esempio di selezione	<i>Selection example</i>	Beispiel für die Auswahl	A8
Verifica a carico di punta	<i>Peak load check</i>	Überprüfung der Spitzenlast	A10
Velocità critica	<i>Critical speed</i>	Kritische Geschwindigkeit	A14
Installazione	<i>Installation</i>	Installation	A16
Posizioni di montaggio	<i>Mounting positions</i>	Einbaulagen	A17
Giochi ed usura	<i>Backlash and wear</i>	Spiel und Verschleiß	A17

Questa sezione annulla e sostituisce ogni precedente edizione o revisione. Qualora questa sezione non Vi sia giunta in distribuzione controllata, l'aggiornamento dei dati ivi contenuto non è assicurato. **In tal caso la versione più aggiornata è disponibile sul nostro sito internet www.transtecno.com**

This section replaces any previous edition and revision. If you obtained this catalogue other than through controlled distribution channels, the most up to date content is not guaranteed. In this case the latest version is available on our web site www.transtecno.com

Generalità

Il martinetto meccanico permette di trasformare il movimento rotatorio fornito da un motore elettrico in un movimento lineare che consente di effettuare sollevamenti verticali in tiro, in spinta o posizionamenti orizzontali.

General

The mechanical jack makes it possible to transform the rotary movement provided by an electric motor into a linear movement that allows vertical lifting, directly or in thrust mode, or horizontal positioning.

Allgemeine Informationen

Das mechanische Hubgetriebe ermöglicht es, die von einem Elektromotor erzeugte Drehbewegung in eine lineare Bewegung umzuwandeln, die ein vertikales Anheben beim Ziehen, Schieben oder horizontalen Positionieren ermöglicht.

Simbologia

Symbols

Symbole

F	[N]	Carico / Load / Last
P	[kW]	Potenza necessaria / Power required / Erforderliche Leistung
p	[mm]	Passo dello stelo filettato / Leadscrew/ballscrew pitch / Gewindesteigung
η_m		Rendimento martinetto / Overall screwjack efficiency / Wirkungsgrad des Spindelhubgetriebes
η_c		Rendimento della configurazione / Overall system efficiency / Wirkungsgrad des Konfiguration
i		Rapporto di riduzione martinetto / Reduction ratio / Untersetzungsverhältnis des Spindelhubgetriebes
M_t	[Nm]	Momento torcente in ingresso al martinetto o al sistema di martinetti / Torque at the input of the jack or jack system / Drehmoment am Eingang des Hubgetriebe oder des Hubgetriebesystems
M_l	[Nm]	Momento torcente a vuoto / Idling torque / Leerlaufmoment
n_1	[rpm]	Numero di giri in ingresso al martinetto / Speed at the input of the jack / Drehzahl am Eingang des Spindelhubgetriebes
sf		Fattore di servizio / Service factor
V	[mm/s]	Velocità di traslazione / Linear speed / Bewegungsgeschwindigkeit
n		Numero di martinetti / Number of screwjacks / Anzahl der Spindelhubgetriebe
N		Numero totale di martinetti e rinvii / Number of screwjacks and bevelgears / Gesamtanzahl der Spindelhub- und Kegelradgetriebe

Definizione dei carichi

Load definition

Festlegen der belastungen

CARICHI STATICI

Sono statici, per definizione, tutti quei carichi che agiscono sul martinetto quando tutti i suoi componenti si trovano in stato di quiete.

STATIC LOADS

By definition, all loads acting on the jack when all its components are at rest are static loads.

STATISCHE BELASTUNGEN

Statisch sind definitionsgemäß alle Belastungen, die auf das Spindelhubgetriebe einwirken, wenn sich all seine Komponenten im Ruhezustand befinden.

CARICHI DINAMICI

Sono dinamici, per definizione, tutti quei carichi che agiscono sul martinetto mentre i suoi componenti sono in movimento, qualunque esso sia.

DYNAMIC LOADS

By definition, all loads acting on the jack while its components are moving are dynamic loads.

DYNAMISCHE BELASTUNGEN

Dynamisch sind definitionsgemäß alle Belastungen, die auf das Spindelhubgetriebe einwirken, wenn sich seine Komponenten in Bewegung befinden, egal welcher Art.

CARICHI IN TRAZIONE

Un carico si definisce in trazione quando agisce sull'asse dello stelo filettato in verso opposto al corpo martinetto. In questo caso il martinetto può lavorare al carico massimo ammissibile.

PULL LOADS

A pull or tension load is a load that acts on the spindle axis in the opposite direction to the jack housing. In this case the jack can work at the maximum permissible load.

ZUGBELASTUNGEN

Man spricht von einer Zugbelastung, wenn sie auf die Achse des Gewindeschafte in entgegengesetzter Richtung zum Körper des Spindelhubgetriebes einwirkt. In diesem Fall kann das Spindelhubgetriebe mit der maximal zulässigen Belastung arbeiten.

CARICHI IN COMPRESSIONE

Un carico si definisce in compressione quando agisce sull'asse dello stelo filettato in direzione del corpo del martinetto. In questo caso particolare lo stelo filettato può essere soggetto al cosiddetto "carico di punta" da cui consegue una limitazione del carico massimo ammesso sul martinetto. (vedi sezione calcolo martinetti pag. A7).

PUSH LOADS

A push or compression load is a load that acts on the spindle axis in the direction of the jack housing. In this particular case the spindle may be subject to so-called "buckling load" so there is a limitation to the maximum permissible load on the jack (see jack calculations section page A7)

DRUCKBELASTUNGEN

Man spricht von einer Druckbelastung, wenn sie auf die Achse des Gewindeschafte in Richtung zum Körper des Spindelhubgetriebes einwirkt. In diesem Fall kann vor allem die Gewindespindel einer sogenannten „Höchstlast“ ausgesetzt sein, aus der sich eine Einschränkung der maximal zulässigen Belastung am Spindelhubgetriebe ergibt (siehe Abschnitt. A7).

Carichi massimi ammessi

Maximum permissible loads

Maximal zulässige belastungen

I martinetti sono progettati per sopportare sia in trazione che in compressione il carico nominale statico ammesso.

Il carico ammesso dipende dal tipo di fissaggio del martinetto e dalla direzione del carico.

The jacks are designed to withstand the nominal static load permitted in tension and compression.

The permissible load depends on the type of jack mounting and the load direction.

Die Spindelhubgetriebe sind so ausgelegt, dass sie sowohl bei Zug- als auch bei Druckbelastungen der zulässigen statischen Nennlast standhalten. Die zulässige Belastung hängt von der Art der Befestigung des Spindelhubgetriebes und der Lastrichtung ab.

A) Montaggio del martinetto in appoggio sul piano, stelo rivolto verso l'alto e carico in compressione.

Il carico statico massimo può essere limitato rispetto al nominale, in funzione della corsa del martinetto. Occorre verificare la lunghezza dello stelo a carico di punta.

A) Jack resting on level surface, spindle facing upwards and push load.

The maximum static load may be limited with respect to the nominal load, depending on the stroke of the jack. The length of the spindle must be checked at buckling load.

A) Montage des Spindelhubgetriebes auf einer Fläche aufliegend, Schaft nach oben gerichtet und unter Druckbelastung.

Die maximale statische Belastung kann je nach Hub des Spindelhubgetriebes im Vergleich zur Nennlast geringer sein. Es muss überprüft werden, wie lang der Schaft bei der Höchstlast ist.

B) Montaggio del martinetto in appoggio sul piano, stelo rivolto verso il basso e carico in trazione.

I martinetti possono sopportare il carico statico nominale massimo.

B) Jack resting on a flat surface, spindle facing downwards and pull load.

The jacks can withstand the maximum nominal static load.

B) Montage des Spindelhubgetriebes auf einer Fläche aufliegend, Schaft nach unten gerichtet und unter Zugbelastung.

Das Spindelhubgetriebe kann der maximalen statischen Nennlast standhalten.

C) Montaggio del martinetto fissato sotto al piano, stelo rivolto verso il basso e carico in trazione, che grava sulle viti di fissaggio.

I martinetti possono sopportare il carico nominale statico massimo solo se vengono rispettate le specifiche di fissaggio: la lunghezza vite e la coppia di serraggio. (Tali valori sono riportati sul manuale uso e manutenzione).

Si sconsiglia questo tipo di montaggio, se non strettamente necessario.

È preferibile applicare i martinetti con fissaggi in appoggio sul piano.

C) Jack mounted under a flat surface, spindle facing downwards and pull load supported by the fixing screws.

The jacks can withstand the maximum nominal static load only if the fixing specifications are observed: screw length and tightening torque. (These values are given in the use and maintenance manual).

This type of fixing should be avoided unless absolutely necessary.

It is preferable to fix the jacks on top of a flat surface.

C) Montage des Spindelhubgetriebes an einer Fläche hängend, Spindel nach unten gerichtet und unter Zugbelastung, die auf die Befestigungsschrauben wirkt.

Die Spindelhubgetriebe können der maximalen statischen Nennlast nur dann standhalten, wenn die Befestigungsvorgaben eingehalten werden: Schraubenlänge und Anzugsdrehmoment (diese Werte finden Sie in der Betriebs- und Wartungsanleitung).

Diese Art der Montage sollte vermieden werden, wenn sie nicht absolut erforderlich ist. Vorzugsweise sollten die Spindelhubgetriebe auf einer Fläche aufliegend montiert werden.

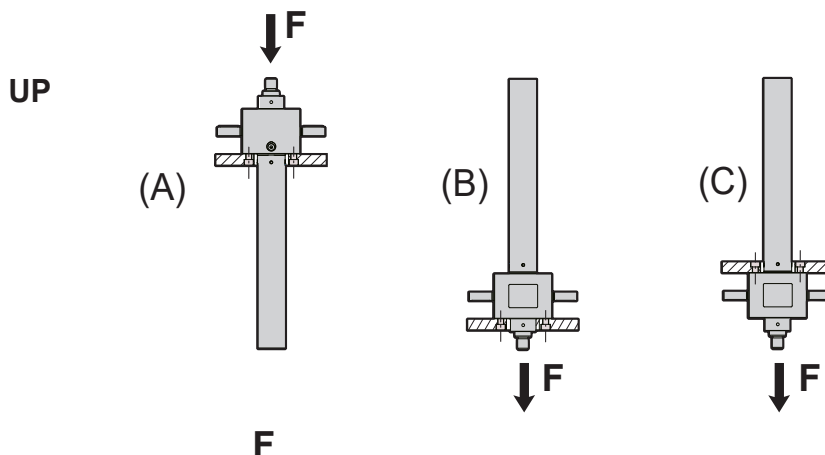

Coppie in ingresso ai martinetti

COPPIA MASSIMA AMMESSA IN INGRESSO AI SINGOLI MARTINETTI

Per una durata ottimale del martinetto occorre non superare i valori di coppia massima in ingresso riportati nella tabella dei "dati tecnici generici" (pag.B19-B27).

COPPIA MOTRICE PER SINGOLO MARTINETTO

Le coppie motrici necessarie per il sollevamento del carico di un singolo martinetto sono riportate nelle "tabelle prestazionali" (pag.B20-B21-B28-B29). Nel caso in cui il carico da movimentare non sia riportato nelle tabelle fare riferimento al capitolo "formule di calcolo" (pag.A14).

COPPIA MASSIMA AMMISSIBILE IN INGRESSO AI MARTINETTI

In sistemi composti da più martinetti, alimentati da un unico motore, occorre verificare la coppia massima ammessa in ingresso dei singoli martinetti.

I valori sono riportati nella tabella dei "dati tecnici generici" (pag.B19-B27). Nel caso in cui il valore venisse superato è necessario scegliere una taglia superiore, cambiare lo schema di montaggio o modificare la velocità, compatibilmente con quanto riportato nei paragrafi precedenti.

COPPIA MOTRICE PER SISTEMI DI SOLLEVAMENTO

Per il calcolo della coppia motrice necessaria ad un sistema a più martinetti non è sufficiente sommare le singole coppie dei vari martinetti ma occorre tenere conto del rendimento del sistema. Per fare il calcolo fare riferimento al capitolo "formule di calcolo" (pag.A7).

Jack input torque

MAXIMUM PERMISSIBLE INPUT TORQUE FOR INDIVIDUAL JACKS

For optimal life of the jack, the maximum input torque values shown in the „general technical data“ table (page B19-B27) must not be exceeded.

DRIVE TORQUE FOR A SINGLE JACK

The drive torques required for load lifting by a single jack are given in the „performance tables“ (page B20-B21-B28-B29).

If the load to be lifted is not shown in the tables, refer to the „calculation formulas“ chapter (page A14).

MAXIMUM ALLOWABLE INPUT TORQUE TO THE JACKS

In systems consisting of several jacks, powered by a single motor, the maximum allowable input torque to the individual jacks must be checked. The values are given in the „General technical data“ table (page B19-B27). If the value is exceeded, it is necessary to choose a larger size, change the mounting layout or modify the speed, in accordance with the previous paragraphs.

DRIVE TORQUE FOR LIFTING SYSTEMS

To calculate the drive torque required for a multi-jack system, it is not sufficient to sum the individual torque values of the various jacks: the efficiency of the entire system must be taken into account. To perform the calculation, refer to the „calculation formulas“ chapter (page A7).

Eingangsdrehmoment an spindelhubgetrieben

MAXIMAL ZULÄSSIGES EINGANGSDREHMOMENT AN EINZELNEN SPINDELHUBGETRIEBEN

Um eine optimale Lebensdauer des Spindelhubgetriebes zu gewährleisten, sollten die in der Tabelle „Allgemeine technische Daten“ (Seite B19-B27) angegebenen Werte für das maximale Eingangsdrehmoment nicht überschritten werden.

ANTRIEBSDREHMOMENT AM EINZELNEN SPINDELHUBGETRIEBE

Die erforderlichen Antriebsdrehmomente zum Anheben der Last eines einzelnen Spindelhubgetriebes sind in den „Leistungstabellen“ (Seite B20-B21-B28-B29) angegeben.

Wenn die zu bewegende Last nicht in den Tabellen erscheint, können Sie auf das Kapitel „Berechnungsformeln“ (Seite A14) zurückgreifen.

MAXIMAL ZULÄSSIGES EINGANGSDREHMOMENT AN DEN HEBEBÖCKEN

Bei Systemen mit mehreren Hubgetrieben, die von einem einzigen Motor angetrieben werden, muss das maximal zulässige Eingangsdrehmoment der einzelnen Hubgetrieben überprüft werden. Die Werte sind in der Tabelle „Allgemeine technische Daten“ angegeben (Seite B19-B27). Wenn der Wert überschritten wird, muss ein größeres Format gewählt, das Montagemuster geändert oder die Geschwindigkeit gemäß den vorangegangenen Abschnitten angepasst werden.

ANTRIEBSDREHMOMENT FÜR HEBESYSTEME

Für die Berechnung des Antriebsdrehmoments für ein Spindelhubgetriebesystem reicht es nicht aus, die einzelnen Drehmomente der verschiedenen Spindelhubgewinde zusammenzuzählen, sondern die Systemleistung muss berücksichtigt werden. Informationen zur Berechnung finden Sie im Kapitel „Berechnungsformeln“ (Seite A7).

Velocità di sollevamento

Le velocità di sollevamento sono riportate nelle "tabelle prestazionali" (pag. B20-B21-B28-B29).

Per calcolare la velocità di sollevamento con un numero di giri diverso da quanto riportato in tabella fare riferimento alla formula riportata nel capitolo "formule di calcolo" (pag. A7)

Per aumentare la velocità di traslazione si possono utilizzare viti a due principi che raddoppiano la velocità lineare del martinetto. L'utilizzo di queste viti diminuisce il carico dinamico, che è limitato dalla coppia massima in ingresso al martinetto e rendono il martinetto reversibile. Per sopperire a tale effetto occorre prevedere un freno meccanico.

Per ridurre la velocità di traslazione occorre diminuire i giri in ingresso al martinetto.

Si possono utilizzare motori con un numero di poli superiore, inverter o interporre un riduttore tra motore e martinetto.

In tutti i casi occorre fare sempre attenzione alla coppia massima ammessa in ingresso al martinetto.

Lifting speed

Lifting speeds are shown in the "performance tables" (page B20-B21-B28-B29).

To calculate the lifting speed with an rpm value other than that shown in the table, refer to the formula given in the "calculation formulas" chapter (page A7)

To increase the travel speed, screws with two starts can be used to double the linear speed of the jack.

The use of these screws reduces the dynamic load, which is limited by the jack's maximum input torque. These screws also make the jack reversible, which must be countered by installing a mechanical brake.

To reduce the travel speed, jack input speed must be decreased.

This can be achieved using a motor with a greater number of poles, an inverter, or by interposing a gear reducer between the motor and the jack.

In all cases, always pay attention to the maximum permissible input torque to the jack.

Hubgeschwindigkeit

Die Hubgeschwindigkeiten sind in den „Leistungstabellen“ (Seite B20-B21-B28-B29) angegeben.

Um die Hubgeschwindigkeit bei einer anderen Anzahl von Drehungen zu berechnen, als den in der Tabelle angegebenen, können Sie auf das Kapitel „Berechnungsformeln“ (Seite A7) zurückgreifen.

Um die Versetzungsgeschwindigkeit zu erhöhen, können Sie Doppelgewindeschäfte verwenden, um die lineare Geschwindigkeit des Spindelhubgetriebes zu verdoppeln.

Die Verwendung dieser Gewindeschäfte verringert die dynamische Belastung, die vom maximalen Eingangsdrehmoment am Spindelhubgetriebe abhängt, und macht das Spindelhubgetriebe umkehrbar. Um diesem Effekt entgegenzuwirken, muss eine mechanische Bremse vorgesehen werden.

Um die Versetzungsgeschwindigkeit zu verringern, muss die Eingangsdrehzahl des Spindelhubgetriebes verringert werden.

Es können Motoren mit mehreren Polen, Inverter oder Getriebe zwischen Motor und Spindelhubgetriebe verwendet werden.

In allen Fällen muss immer das maximal zulässige Eingangsdrehmoment am Spindelhubgetriebe berücksichtigt werden.

Corsa

In fase di progettazione occorre fare attenzione alla corsa massima del martinetto rispettando gli extra-corsa di sicurezza.

Non sono ammesse battute meccaniche che potrebbero danneggiare i componenti interni del martinetto.

CONTROLLO DELLA CORSA

Sulla versione traslante, possono essere applicati dei sistemi di controllo per evitare che il martinetto raggiunga le posizioni estreme con conseguente battuta meccanica.

Per la versione rotante il controllo della corsa deve essere previsto sulla struttura da parte del cliente.

Per la selezione del sistema di controllo vedi (pag. D14).

I martinetti non devono lavorare a battuta meccanica.

Eventuali battute meccaniche possono danneggiare il martinetto e/o ridurre la vita utile.

Stroke

During the design stage, pay attention to the screw jack maximum stroke and comply with the safety overrun distances.

Contact with mechanical limit stops that may damage internal components of the jack is not permitted.

STROKE MONITORING

Travelling versions can be equipped with control systems to prevent the jack from reaching stroke limit positions and thus come into contact with a mechanical limit stop.

Stroke control for the rotating version must be incorporated in the structure by the customer's engineering department.

For control system selection, refer to (page D14).

The jacks must not work with a mechanical stop. Mechanical stops may damage the jack and/or reduce its service life.

Hub

Bei der Planung muss besonders auf den maximalen Hub des Spindelhubgetriebes geachtet und der Sicherheits-Zusatzhub muss berücksichtigt werden.

Mechanische Stöße müssen vermieden werden, da sie die internen Komponenten des Spindelhubgetriebes beschädigen könnten.

ÜBERPRÜFUNG DES HUBS

Bei der stehenden Ausführung können Überwachungssysteme eingesetzt werden, die verhindern, dass das Spindelhubgetriebe Extrempositionen erreicht, die zu mechanischen Stößen führen könnten.

Für die rotierende Ausführung muss die Überwachung des Hubs innerhalb der Struktur vom Kunden vorgesehen werden.

Zur Auswahl des Überwachungssystems siehe (Seite D14).

Die Hubgetriebe dürfen nicht mit einem mechanischen Anschlag arbeiten. Mechanische Anschläge können das Hubgetriebe beschädigen und/oder seine Lebensdauer verkürzen.

Lubrificazione

Tutti i martinetti vengono forniti con il gruppo riduttore lubrificato.

ATTENZIONE! La lubrificazione dello stelo è a cura dell'utilizzatore finale.

L'utilizzatore deve ispezionare regolarmente lo stelo ed effettuare la lubrificazione in base al ciclo di lavoro. Lo stelo viene prelubrificato in fase di montaggio con grasso specifico.

Le versioni rotanti con viti a ricircolo di sfere hanno le chiocchie dotate di foro per l'ingrassatore.

Lubrication

All screw jacks are supplied with a lubricated gear unit.

IMPORTANT! *Lubrication of the piston rod is the responsibility of the end user. The user must regularly inspect the piston rod and carry out lubrication according to the work cycle. The piston rod is pre-lubricated with specific grease during assembly.*

The rotating versions with ball screws have nuts with a hole for the grease nipple.

Schmierung

Alle Hubgetriebe werden mit einem geschmierten Getriebe geliefert.

ACHTUNG! Die Schmierung der Kolbenstange liegt in der Verantwortung des Anwenders. Der Anwender muss die Kolbenstange regelmäßig überprüfen und entsprechend dem Arbeitszyklus schmieren. Die Kolbenstange wird bei der Montage mit dem entsprechenden Fett vorgeschmiert.

Die drehbaren Ausführungen mit Kugelumlaufspindeln haben Muttern mit einer Bohrung für den Schmiernippel.

Lubrificazione riduttori / Gearbox lubrication / Schmierung des Getriebes								
Tipo Type Typ	Tipo lubrificante Lubricant type Schmiermitteltyp	Standard		Equivalenti				
		Mobil	Shell	Shell	Agip	Klüber	Molyguard	Total
UP 2.5	Grasso Grease Fett	Mobilux EP 004	-	Alvania grease EP00	Grease MU EP2	Centoplex 3 EP	-	Multis EP00
UP 5 UP 10 UP 25 UP 50 UP 100		-	TVX Compound B	-	Blasia 220	Klubersynth PEG 46-1200	VSF 00	Carter SY 00

Lubrificazione stelo / Piston rod lubrication / Schmierung der Kolbenstangen						
Tipo lubrificante Lubricant type Schmiermitteltyp	Standard		Equivalenti			
	Bechem		Klueber	Total Carter	Rothen	Total
Grasso Grease Fett	Berulub FG-H 2 EP		Staburags NBU 8EP	EP2200 standard	2000/P Special	CERAN WR2

Temperatura di funzionamento e fattore di servizio

In linea di massima i martinetti con vite trapezoidale non sono idonei per il funzionamento continuativo.

Le prestazioni riportate nelle tabelle sono riferite a fattore di servizio e temperatura di funzionamento indicato nelle specifiche tipologie.

In casi limite scegliere un martinetto di dimensioni maggiori oppure per fattori di servizio e temperature diverse contattare il nostro servizio tecnico.

Operating temperature and service factor

In principle, screw jacks with trapezoidal screws are not suitable for continuous operation.

The performances shown in the tables refer to the service factor and operating temperature indicated in the specific types.

In borderline cases, choose a larger jack or for different service factors and temperatures contact our technical service.

Betriebstemperatur und Betriebsfaktor

Hubgetriebe mit Trapezgewindespindeln sind grundsätzlich nicht für den Dauerbetrieb geeignet.

Die in den Tabellen angegebenen Leistungen beziehen sich auf den Betriebsfaktor und die Betriebstemperatur, die bei den einzelnen Typen angegeben sind.

In Grenzfällen wählen Sie ein größeres Getriebe oder wenden Sie sich bei abweichenden Betriebsfaktoren und Temperaturen an unseren technischen Dienst.

Formule di calcolo

Calculation formulas

Berechnungsformeln

Prima di iniziare il dimensionamento occorre valutare attentamente tutti i carichi che gravano sul martinetto o il sistema a più martinetti.

Before starting sizing procedures, carefully evaluate all the loads acting on the jack or the multi-jack system.

Vor der Dimensionierung müssen alle Belastungen, die auf das Spindelhubgetriebe oder das System mit mehreren Spindelhubgetrieben einwirken, bewertet werden.

DIMENSIONAMENTO DI UN SINGOLO MARTINETTO

SIZING A SINGLE JACK

DIMENSIONIERUNG EINES EINZELNEN SPINDELHUBGETRIEBES

Calcolo della coppia necessaria per movimentare il carico:

Calculation of torque needed to move the load:

Berechnung des zum Bewegen der Last erforderlichen Drehmoments:

$$M_t = \frac{F * p}{2000 * 3.14 * \eta_m * i} + M_l$$

Calcolo della potenza necessaria per movimentare il carico:

Calculation of power needed to move the load:

Berechnung der zum Bewegen der Last erforderlichen Leistung:

$$P = \frac{M_t * n_1}{9550}$$

Calcolo della velocità di traslazione:

Travel speed calculation:

Berechnung der Bewegungsgeschwindigkeit:

$$V = \frac{n_1 * p}{i * 60}$$

DIMENSIONAMENTO DI UN SISTEMA A PIU' MARTINETTI

SIZING A MULTI-JACK SYSTEM

DIMENSIONIERUNG EINES SYSTEMS MIT MEHREREN SPINDELHUBGETRIEBEN

La coppia necessaria per un sistema di sollevamento è data dalla somma delle coppie dei singoli martinetti ed è aumentata in funzione delle perdite di attrito dei componenti di trasmissione quali giunti, alberi di collegamento, rinvii angolari ecc.

The torque required for a lifting system is the total of the individual jack torque values and is increased according to the friction losses of the transmission components such as couplings, connecting shafts, bevel gearboxes, etc.

Das für ein Hebesystem erforderliche Drehmoment ergibt sich aus der Summe der Drehmomente der einzelnen Spindelhubgetriebe und wird entsprechend den Reibungsverlusten der Getriebekomponenten wie Kupplungen, Verbindungswellen, Kegelradgetriebe usw. erhöht.

Calcolo della coppia necessaria per movimentare il carico:

Calculation of power needed to move the load:

Berechnung der zum Bewegen der Last erforderlichen Leistung:

$$M_t = \left(\frac{n * F * p}{2000 * 3.14 * \eta_m * i * \eta_c} \right) + (M_l * N)$$

Calcolo della potenza necessaria per movimentare il carico:

Calculation of power needed to move the load:

Berechnung der zum Bewegen der Last erforderlichen Leistung:

$$P = \frac{M_t * n_1}{9550}$$

Calcolo della velocità di traslazione:

Travel speed calculation:

Berechnung der Bewegungsgeschwindigkeit:

$$V = \frac{n_1 * p}{i * 60}$$

Esempio di selezione

Selection example

Auswahlbeispiel

Esempio di selezione singolo martinetto.

Dati:
Carico da sollevare: $F = 18000 \text{ N}$
Corsa: 500 mm
Tempo max. per effettuare la corsa: $t_{\max} = 30 \text{ s}$

Selezionare la taglia di martinetto che ammette un carico statico immediatamente superiore a $F = 18000 \text{ [N]}$ da sollevare.

taglia 25 (carico statico ammissibile 25000 N)

Calcolo della velocità di traslazione:

$$v = \frac{\text{Corsa}}{t_{\max}} = \frac{500}{30} = 16.6 \text{ [mm/s]}$$

Dalla tabella delle caratteristiche generali, per la taglia 25, si identifica il rapporto normale "N" $i = 1:6$.

Dalla stessa tabella si definisce la vite di 30×6 (diametro x passo) con rendimento meccanico

$\eta_m = 0.30$ e coppia a vuoto $M_l = 0.36 \text{ [Nm]}$

Calcolo del momento torcente necessario a sollevare il carico:

$$M_t = \frac{F \cdot p}{2000 \cdot 3.14 \cdot \eta_m \cdot i} + M_l = \frac{18000 \cdot 6}{2000 \cdot 3.14 \cdot 0.30 \cdot 6} + 0.36 = 9.9 \text{ [Nm]}$$

Nell'ipotesi di utilizzo di un motore trifase a 4 poli alimentato a 50 Hz (1400 rpm), abbiamo necessità di una potenza motore pari a:

Esempio sigla prodotto:

Example of single jack selection.

Data:
Load to be lifted: $F = 18000 \text{ N}$
Stroke: 500 mm
Max. time for stroke: $t_{\max} = 30 \text{ s}$

Select the jack size which admits a static load immediately above $F = 18000 \text{ [N]}$ to be lifted.

size 25 (allowable static load 25000 N)

Calculation of the translation speed:

$$v = \frac{\text{Stroke}}{t_{\max}} = \frac{500}{30} = 16.6 \text{ [mm/s]}$$

From the table of general characteristics, for size 25, the normal ratio is "N" $i = 1:6$.

From the same table, a screw of 30×6 (diameter x pitch) is defined with mechanical efficiency

$\eta_m = 0.30$ and No-Load Torque $M_l = 0.36 \text{ [Nm]}$

Calculation of the torque required to lift the load:

Assuming that a 4-pole three-phase motor supplied at 50 Hz (1400 rpm) is used, we need a motor power equal to:

$$P = \frac{M_t \cdot n_1}{9550} = \frac{9.9 \cdot 1400}{9550} = 1.45 \text{ [kW]}$$

Example product designation:

UP25-T-A-N-TR30x6-0500-TE

Beispiel für die Auswahl eines einzelnen Hubgetriebes

Daten:
Zu hebende Last: $F = 18000 \text{ N}$
Hub: 500 mm
Maximale Laufzeit für den Hub: $t_{\max} = 30 \text{ s}$

Wählen Sie die Größe des Hubgetriebes, der eine statische Last von unmittelbar über $F = 18000 \text{ [N]}$ heben kann.

Größe 25 (zulässige statische Belastung 25000 N)

Berechnung der Laufgeschwindigkeit:

$$v = \frac{\text{Hub}}{t_{\max}} = \frac{500}{30} = 16.6 \text{ [mm/s]}$$

Aus der Tabelle der allgemeinen Merkmale ergibt sich für die Größe 25 das normale Verhältnis "N" $i = 1:6$.

Aus derselben Tabelle ergibt sich eine Schraube von 30×6 (Durchmesser x Steigung) mit einem mechanischen Wirkungsgrad.

$\eta_m = 0.30$ und einem Leerlaufdrehmoment $M_l = 0.36 \text{ [Nm]}$

Berechnung des zum Heben der Last erforderlichen Drehmoments:

Unter der Annahme, dass ein 4-poliger Drehstrommotor mit einer Frequenz von 50 Hz (1400 U/min) verwendet wird, benötigen wir eine Motorleistung in Höhe von:

Beispiel für eine Produktbezeichnung:

Esempio di selezione

Selection example

Auswahlbeispiel

Esempio di selezione martinetto multiplo 4.C (rendimento $\eta_c = 0.8$)

Example of multiple jack selection 4.C (efficiency $\eta_c = 0.8$)

Beispiel für die Auswahl mehrerer Hubgetriebe 4.C (Wirkungsgrad $\eta_c = 0,8$)

Dati:
Carico da sollevare: 30000 N
Corsa: 200 mm
Tempo max. per effettuare la corsa: $t_{max} = 40$ s
Carico su singolo martinetto 30000/4
 $F = 7500$ N

Data:
Load to be lifted: $F = 30000$ N
Stroke: 200 mm
Max. time for stroke: $t_{max} = 40$ s
Single jack load 30000/4
 $F = 7500$ N

Daten:
Zu hebende Last: $F = 30000$ N
Hub: 200 mm
Maximale Laufzeit für den Hub: $t_{max} = 40$ s
Einzelne Hebebocklast 30000/4
 $F = 7500$ N

Selezionare la taglia del singolo martinetto che ammetta un carico statico immediatamente superiore a 7500 [N]:

Select the jack size which admits a static load immediately above $F = 7500$ [N]:

Wählen Sie die Größe des Hubgetriebes, der eine statische Last von unmittelbar über $F = 7500$ [N] heben kann.

taglia 10 (carico statico ammissibile 10000N)

size 10 (allowable static load 10000 N)

Größe 10 (zulässige statische Belastung 10000 N)

Calcolo della velocità di traslazione:

Calculation of the translation speed:

Berechnung der Laufgeschwindigkeit:

$$v = \frac{\text{Corsa}}{t_{max}} = \frac{200}{40} = 5 \text{ [mm/s]}$$

$$v = \frac{\text{Stroke}}{t_{max}} = \frac{200}{40} = 5 \text{ [mm/s]}$$

$$v = \frac{\text{Hub}}{t_{max}} = \frac{200}{40} = 5 \text{ [mm/s]}$$

In funzione della velocità calcolata, per la taglia 10, si identifica il rapporto lento "L" $i = 1:16$

Depending on the calculated speed, the slow ratio "L" $i = 1:16$ is identified for size 10

Abhängig von der berechneten Geschwindigkeit wird das langsame Verhältnis "L" $i = 1:16$ für Größe 10 ermittelt.

Dalla stessa tabella si definisce la vite di 20x4 (diametro x passo) con rendimento meccanico

The same table defines the 20x4 screw (diameter x pitch) with mechanical efficiency

Aus derselben Tabelle ergibt sich eine Schraube von 20x4 (Durchmesser x Steigung) mit einem mechanischen Wirkungsgrad

$\eta_m = 0.27$ e coppia a vuoto $MI = 0.16$ [Nm]

$\eta_m = 0.27$ and No-Load Torque $MI = 0.16$ [Nm]

$\eta_m = 0.27$ und einem Leerlaufdrehmoment $MI = 0.16$ [Nm]

Calcolo del momento torcente necessario a sollevare il carico con martinetto multiplo:

Calculation of the torque required to lift the load with a multiple jack:

Berechnung des zum Heben der Last erforderlichen Drehmoments mit mehreren Hubgetrieben:

$$M_t = \frac{N * F * p}{2000 * 3.14 * \eta_m * i * \eta_c} + (N * MI) = \frac{4 * 7500 * 4}{2000 * 3.14 * 0.27 * 16 * 0.8} + (0.16 * 4) = 6.2 \text{ [Nm]}$$

Nell'ipotesi di utilizzo di un motore trifase a 4 poli alimentato a 50hz (1400 rpm), abbiamo necessità di una potenza motore pari a:

Assuming that a 4-pole three-phase motor supplied at 50hz (1400 rpm) is used, we need a motor power equal to:

Unter der Annahme, dass ein 4-poliger Drehstrommotor mit einer Frequenz von 50 Hz (1400 U/min) verwendet wird, benötigen wir eine Motorleistung in Höhe von:

$$P = \frac{M_t * n_1}{9550} = \frac{6.2 * 1400}{9550} = 0.9 \text{ [kW]}$$

Esempio sigla prodotto:

Example product designation:

Beispiel für eine Produktbezeichnung:

UP10-R-A-L-TR20x4-0200-CE

Verifica a carico di punta

Buckling load check

Überprüfung Bei Höchstlast

Quando i martinetti sono sottoposti, anche occasionalmente, ad un carico in compressione occorre verificare lo stelo a carico di punta facendo riferimento ai diagrammi di Eulero.

In funzione ai due vincoli che sostengono il martinetto, si identifica il diagramma di riferimento. Selezionato il tipo di fissaggio dai grafici si rileva la lunghezza massima della distanza "L". I grafici sono stati realizzati con un fattore sicurezza 4.

When the jacks are subjected to a compression load - even occasionally, the screw must be verified at buckling load by referring to the Euler diagrams.

Find the reference diagram in accordance with the two constraints that support the jack. Once the type of fixing has been selected, find the maximum length of distance "L" on the graphs. The graphs were plotted with a safety factor of 4.

Wenn die Spindelhubgetriebe, auch nur gelegentlich, einer Druckbelastung ausgesetzt sind, muss die Spindel bei Höchstlast anhand der Euler-Diagramme überprüft werden.

Abhängig von den beiden Einschränkungen, die das Spindelhubgetriebe stützen, gilt das entsprechende Bezugsdiagramm. Nach Auswahl der entsprechenden Grafik für die jeweilige Befestigungsart kann die Maximallänge des Abstands "L" ermittelt werden. Die Grafiken wurden mit einem Sicherheitsfaktor der Größenordnung 4 erstellt.

Verifica a carico di punta

Buckling load check

Überprüfung Bei Höchstlast

EULERO I

EULERO I

EULERO I

Tipo vincoli:

Constraint types:

Art der Einschränkungen:

Versione Traslante.

Travelling Version.

Stehende Ausführung

- Carter martinetto incastrato.
- Terminale vite libero.

- Fixed housing.
- Unrestrained screw terminal.

- Stehende Ausführung
- Gehäuse des Spindelhubgetriebes fixiert, Spindelende frei.

Versione rotante

Rotating version

Rotierende Ausführung

- Carter martinetto incastrato.
- Chiocciola libera.

- Fixed housing.
- Unrestrained nut.

- Gehäuse des Spindelhubgetriebes fixiert
- Laufmutter frei.

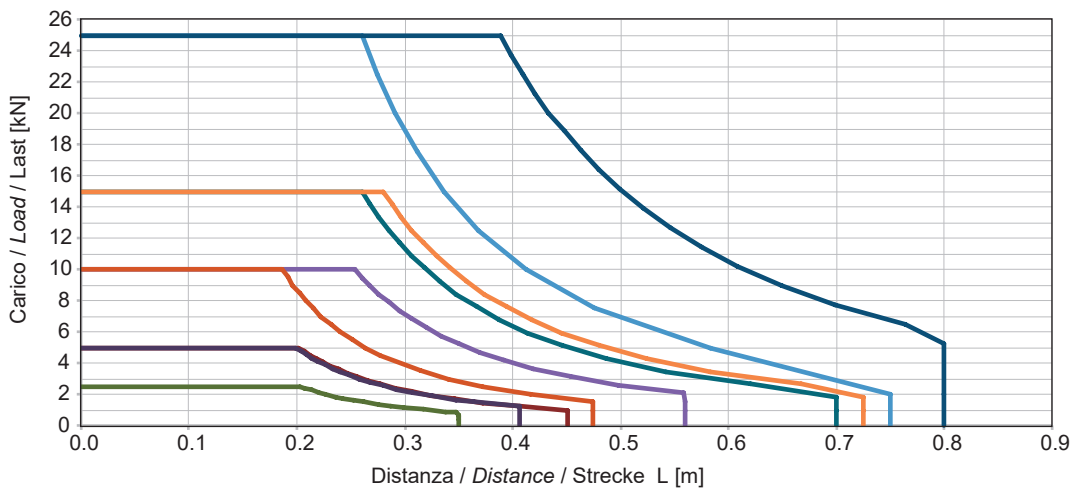
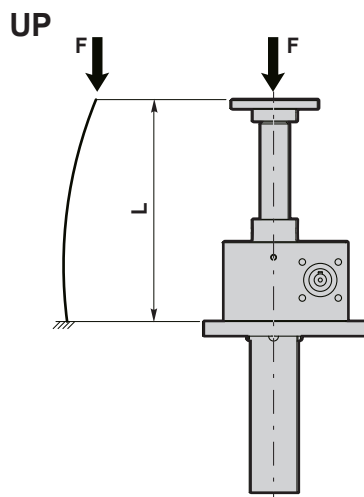

Eulero I

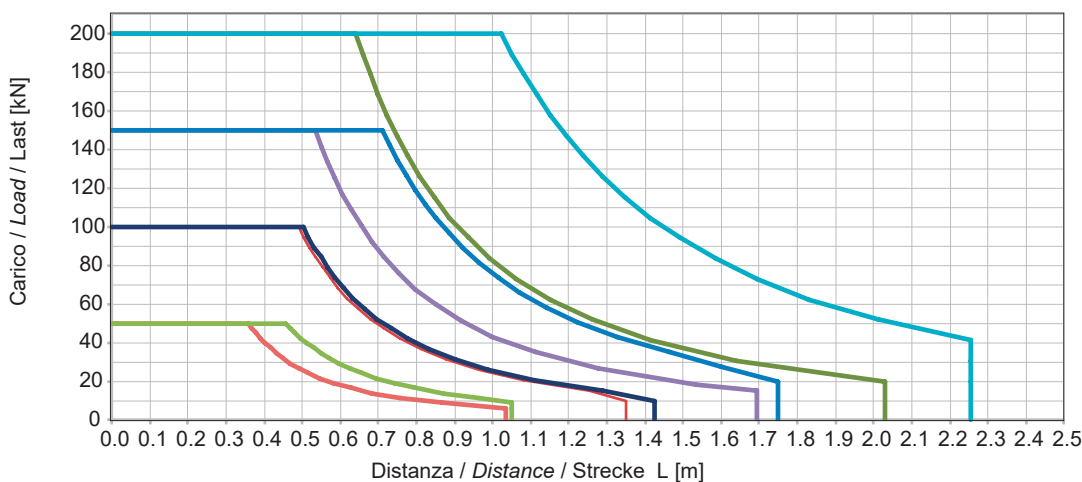

Eulero I

Verifica a carico di punta

Buckling load check

Überprüfung Bei Höchstlast

EULERO II

EULERO II

EULERO II

Tipo vincoli:

Constraint types:

Art der Einschränkungen:

Versione Traslante

Travelling Version

Stehende Ausführung

- Carter martinetto e terminale vite incernierati.

Hinged jack and screw terminal.

- Gehäuse des Spindelhubgetriebes und Spindelende schwenkbar.

Versione rotante

Rotating version

Rotierende Ausführung

- Carter martinetto e chiocciola incernierati.

- Hinged jack and nut.

- Gehäuse des Spindelhubgetriebes und Laufmutter schwenkbar.

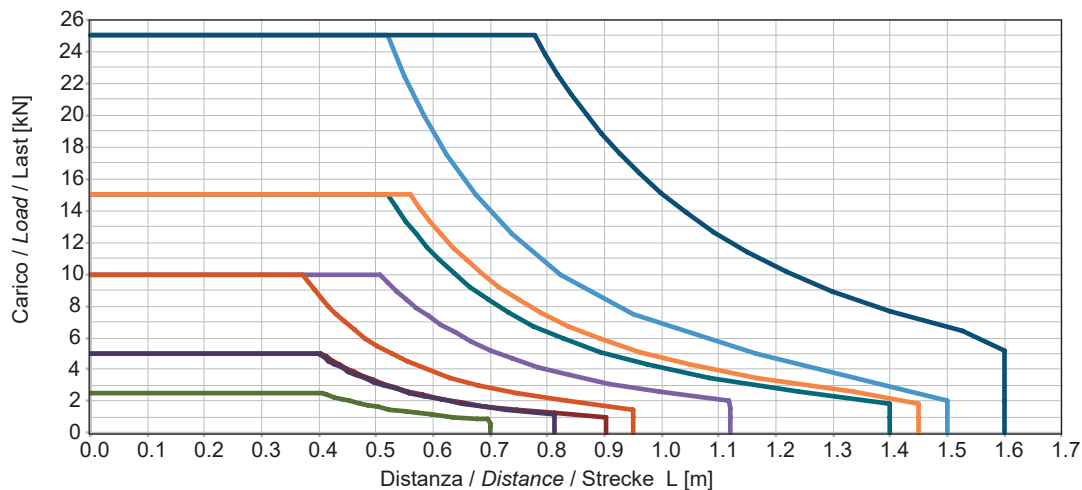
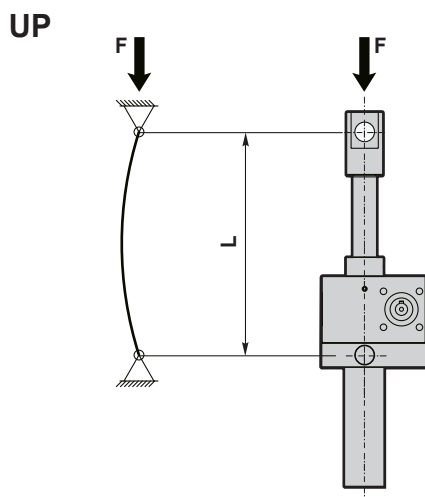

Eulero II

- Tr 16x4
- VRS D.16
- Tr 18x4
- VRS D.20
- Tr 20x4
- VRS D.25
- Tr 25x5
- Tr 30x6
- VRS D.32

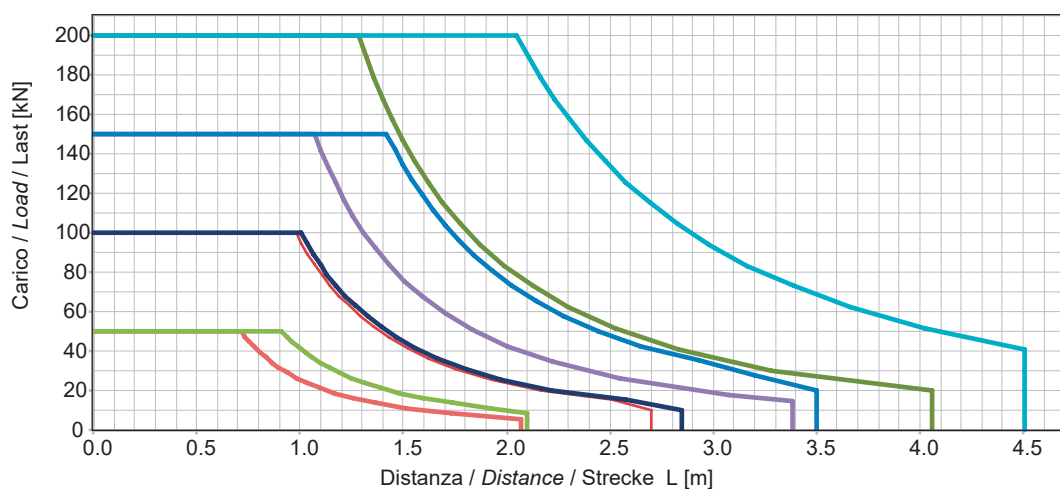

Eulero II

- Tr 40x7
- VRS D.40
- VRS D.50
- Tr 55x9
- Tr 60x9
- VRS D.63
- Tr 70x10
- VRS D.80

Verifica a carico di punta

Buckling load check

Überprüfung Bei Höchstlast

EULERO III

Tipo vincoli:

Versione Traslante

- Carter martinetto incastrato.
- Terminale vite guidato.

Versione rotante

- Carter martinetto incastrato.
- Chiocciola guidata.

EULERO III

Constraint types:

Travelling Version

- Fixed jack housing.
- Guided screw terminal.

Rotating version

- Fixed jack housing.
- Guided nut.

EULERO III

Art der Einschränkungen:

Stehende Ausführung

- Gehäuse des Spindelhubgetriebes fixiert.
- Spindelende geführt.

Rotierende Ausführung

- Gehäuse des Spindelhubgetriebes fixiert.
- Lauffutter geführt.

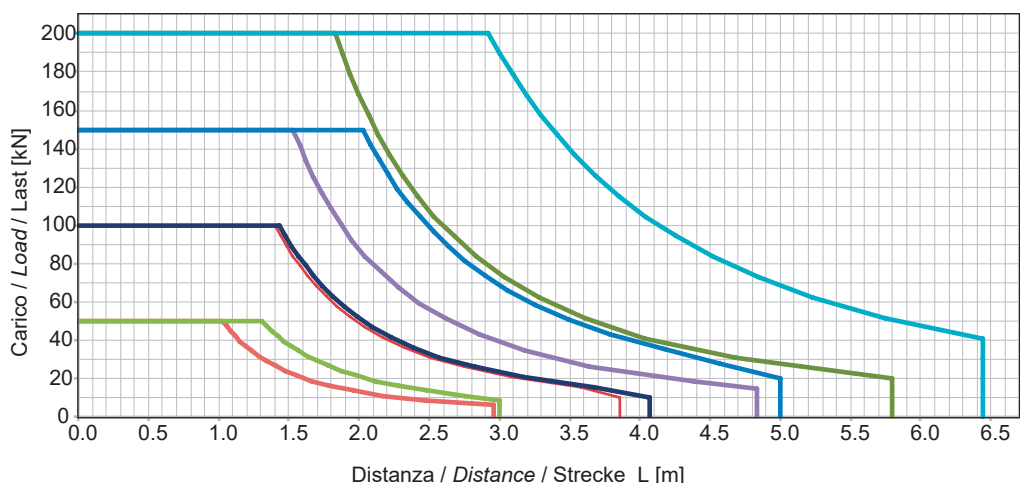
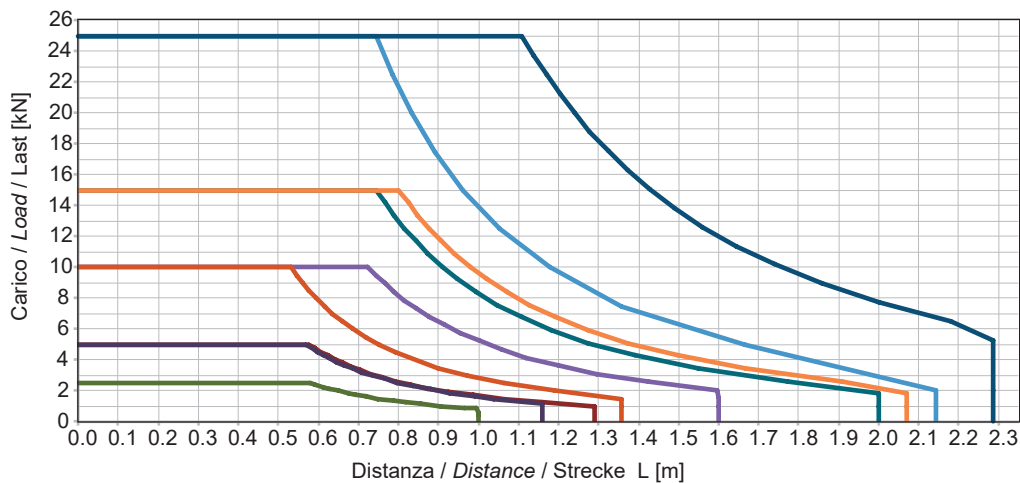
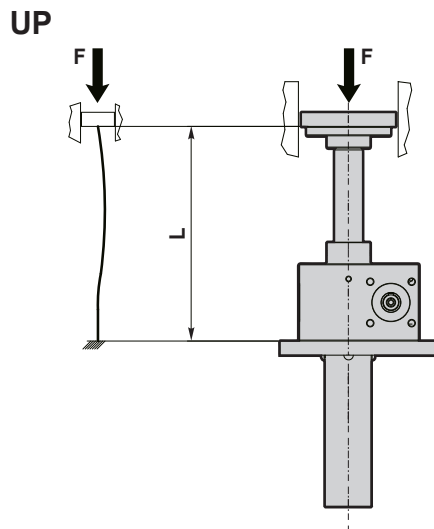

Velocità critica

Un altro elemento fondamentale nella scelta della vite a ricircolo di sfere è la velocità critica.
Essa dipende dal tipo di fissaggio, dal diametro nocciolo e dalla massima lunghezza libera L (non supportata).

Nc = Velocità critica [rpm]
Np = Velocità ammessa
Fn = Tipo di fissaggio

Critical speed

Another important factor to be taken into consideration when selecting recirculating ball screws is critical speed.
This depends on the type of support, on core diameter and on maximum free (unsupported) length L.

$$N_p = N_c \cdot F_n \cdot 0,8 \text{ [rpm]}$$

Nc = Critical speed [rpm]
Np = Permitted speed
Fn = Type of fixture

Kritische Geschwindigkeit

Ein weiteres grundlegendes Element bei der Wahl der Kugelumlaufspindel ist die kritische Geschwindigkeit. Sie hängt von der Art der Befestigung, dem Kerndurchmesser und der maximalen freien Länge L (freitragend) ab.

Nc = Kritische Geschwindigkeit [U/min]
Np = Zulässige Geschwindigkeit
Fn = Art der Befestigung

EULERO I

EULERO II

EULERO III

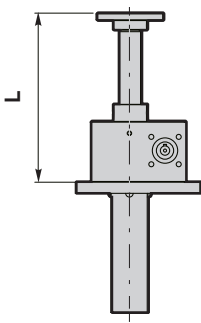
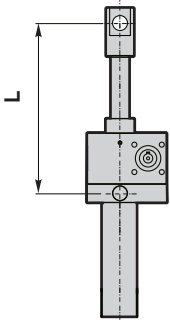
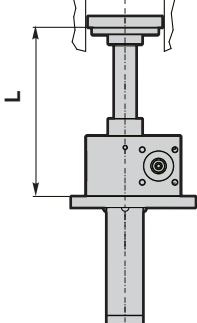
			
Fn	0.35	1.00	1.56

Viti a ricircolo di sfere/ Ball screws / Kugelumlaufspindel

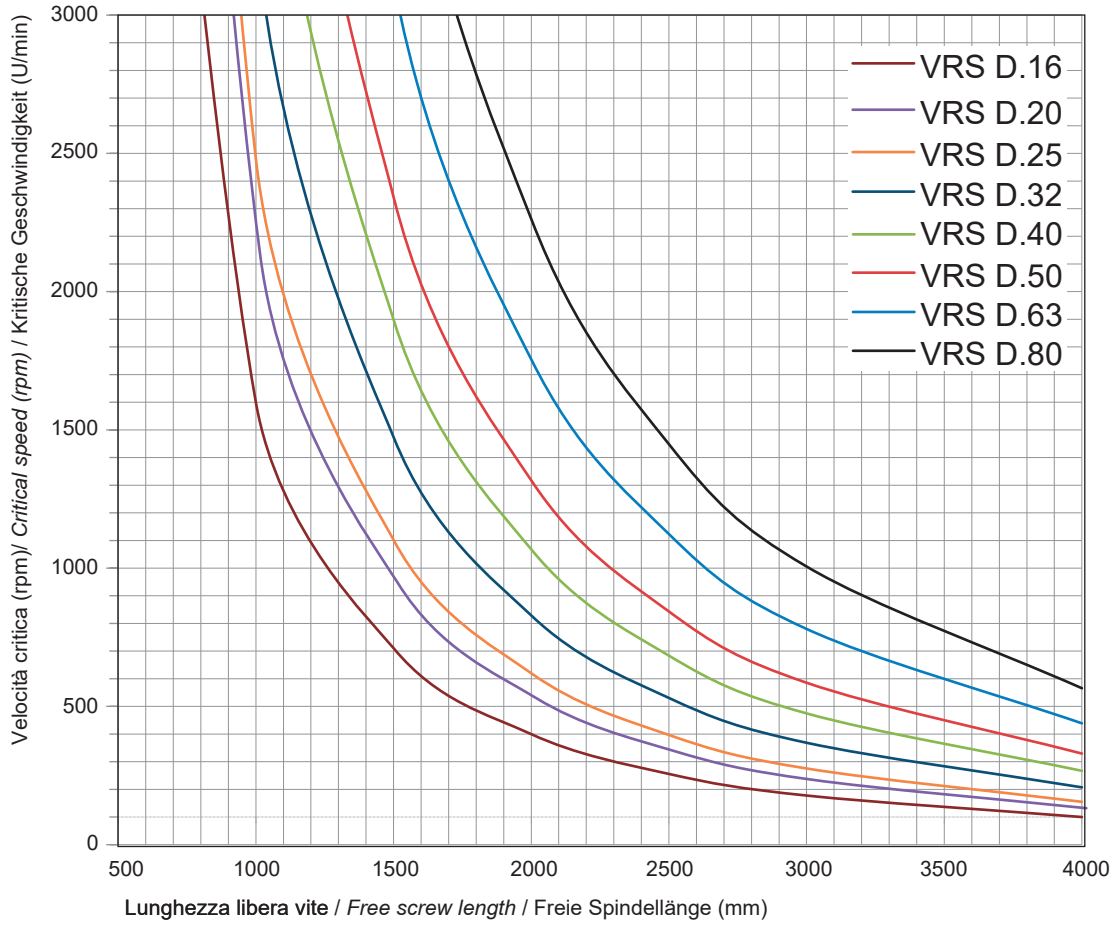

Viti Trapezoidali / Trapezoidal screws / Trapezspindel

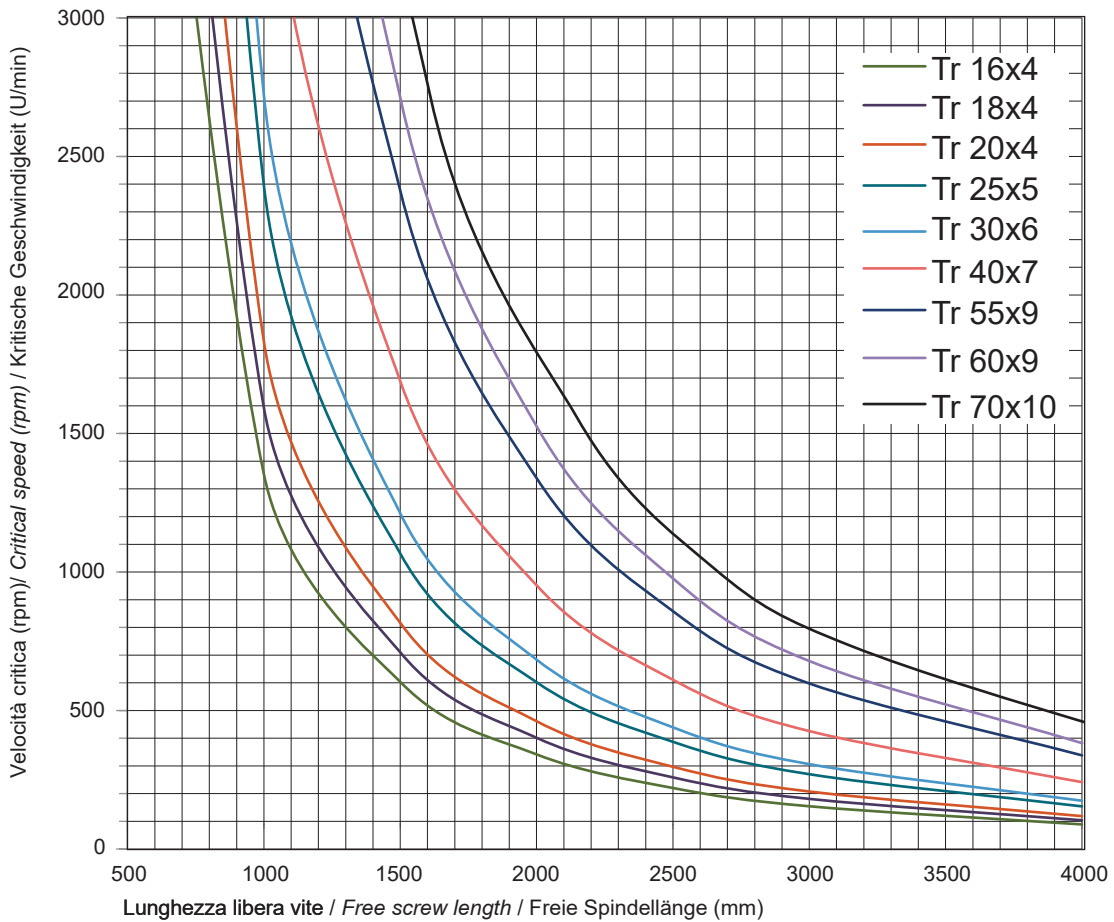

Installazione

In sede di progettazione è necessario scegliere accuratamente la tipologia di fissaggio del martinetto in modo tale da sottoporlo a soli carichi assiali.

Occorre porre la massima attenzione al parallelismo e all'ortogonalità del sistema.

In sistemi a più martinetti occorre garantire il parallelismo tra un martinetto e l'altro.

Errori di parallelismo possono compromettere il corretto funzionamento del sistema causando surriscaldamenti, usure precoci o rotture.

Durante la messa in servizio del martinetto o del sistema, occorre eseguire una serie di controlli attenendosi a quanto riportato sul manuale uso e manutenzione.

Installation

Choose the type of jack fixing in the design stage, to ensure it is subjected to exclusively axial loads.

Pay the utmost attention to parallelism and orthogonality of the system.

In multi-jack systems, parallelism must be guaranteed between one jack and the next.

Parallelism errors can compromise correct operation of the system, causing overheating, premature wear or failure.

During commissioning of the jack or system, a series of checks must be carried out following the instructions in the use and maintenance manual.

Installation

Bei der Planung muss die Befestigungsart des Spindelhubtriebes sorgfältig gewählt werden, damit diese nur axialen Belastungen ausgesetzt wird.

Parallele und rechteckiger Ausrichtung des Systems muss höchste Aufmerksamkeit gewidmet werden.

Bei Systemen mit mehreren Spindelhubtrieben muss auch die parallele Ausrichtung zwischen den Spindelhubtrieben gewährleistet sein.

Fehler bei der Ausrichtung können den korrekten Betrieb des Systems beeinträchtigen und zu Überhitzung, vorzeitigem Verschleiß oder Brüchen führen.

Bei der Inbetriebnahme des Spindelhubtriebes oder des Systems müssen eine Reihe von Prüfungen nach den Anweisungen im Betriebs- und Wartungshandbuch durchgeführt werden.

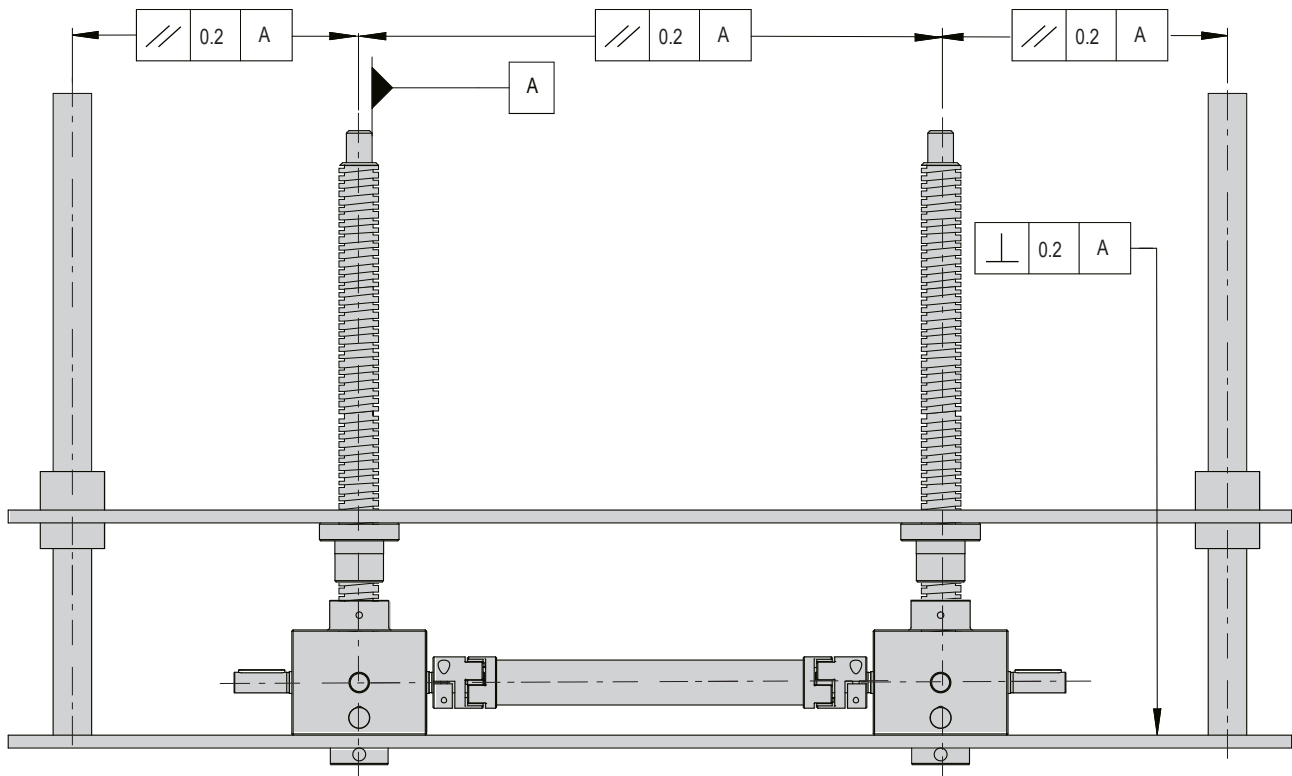

Posizioni di montaggio

Mounting positions

Einbaulagen

I martinetti serie UP possono essere montati indifferentemente in qualsiasi posizione di montaggio.

UP series screw jacks can be mounted in any position.

Die Hubgetriebe der Serie UP können in jeder beliebigen Position montiert werden.

Giochi ed usura

Backlash and wear

Spiel und Verschleiss

GIOCHI ASSIALI

AXIAL BACKLASH

AXIALSPIEL

Tra lo stelo filettato e la madrevite è presente un gioco assiale, necessario per il corretto funzionamento di questo tipo di accoppiamento. Tale gioco assiale è rilevabile solo nelle applicazioni in cui il carico passa da compressione a trazione o viceversa.

There is a certain amount of axial backlash between the screw spindle and the nut, as necessary for this type of coupling to function properly.

The axial backlash can only be detected in applications in which the load changes from compression to traction or vice versa.

Zwischen Gewindespindel und Spindelmutter besteht ein axiales Spiel, das für den korrekten Betrieb dieser Kupplungsart erforderlich ist. Dieses axiale Spiel macht sich nur bei Anwendungen bemerkbar, bei denen eine Druckbelastung zu einer Zugbelastung wechselt oder umgekehrt.

USURA DELLA MADREVITE

(Solo per versioni con viti trapezoidali)

NUT WEAR

(Only for versions with trapezoidal screws)

VERSCHEISS DER SPINDELMUTTER

(Nur für Ausführungen mit Trapezspindeln)

Il controllo dell'usura della madrevite deve avvenire periodicamente ad intervalli regolari. L'usura massima ammessa tra vite e madrevite è pari al 25% del passo.

Nut wear must be checked at regular intervals. The maximum permissible wear between screw and nut is 25% of the pitch.

Die Kontrolle des Verschleißes der Spindelmutter sollte in regelmäßigen Zeitabständen erfolgen. Der maximal zulässige Verschleiß zwischen Gewindespindel und Spindelmutter beträgt 25 % der Steigung.

Tipo di vite Type of Nut Spindelart	Passo Pitch Steigung [mm]	Usura massima ammessa Maximum Permissible Wear Maximal Zulässiger Verschleiss [mm]
16x4, 18x8, 20x4	4	1
25x5	5	1.2
30x6	6	1.5
40x7	7	1.75
55x9, 60x9	9	2.25
70x10	10	2.5

Martinetti
Screw jacks
Hubgetriebe

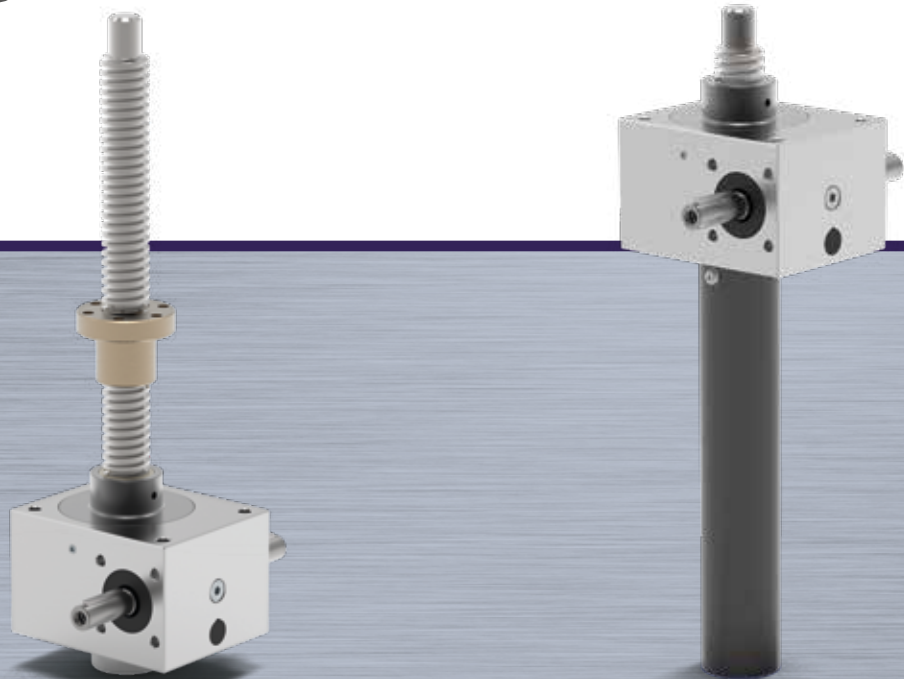

Indice	Index	Index	
Generalità	<i>General</i>	Allgemeine Informationen	B2
Caratteristiche tecniche	<i>Technical specifications</i>	Technische Daten	B2
Codice di ordinazione	<i>Order code</i>	Bestellnummer	B3
Versione	<i>Version</i>	Version	B4
Motori applicabili e flangia motore	<i>Applicable motors and motor flange</i>	Geeignete Motoren und Motorflansche	B5
Lubrificazione e pesi	<i>Lubrication and weights</i>	Schmierung und Gewichte	B6
Temperatura di funzionamento e fattore di servizio	<i>Operating temperature and service factor</i>	Betriebstemperatur und Betriebsfaktor	B6
Irreversibilità / reversibilità	<i>Irreversibility / reversibility</i>	Irreversibilität / Reversibilität	B7
Direzione di rotazione e di movimento	<i>Rotation and movement direction</i>	Drehrichtung und Bewegung	B7
Sensi di rotazione per sistemi multipli	<i>Rotation directions for multiple systems</i>	Rotationsrichtungen für multiple Systeme	B7
Schemi di montaggio	<i>Assembly diagrams</i>	Diagramme zur Montage	B8
2 martinetti	<i>2 screw jacks</i>	2 Hubgetriebe	B9
3 martinetti	<i>3 screw jacks</i>	3 Hubgetriebe	B10
4 martinetti	<i>4 screw jacks</i>	4 Hubgetriebe	B13
6 martinetti	<i>6 screw jacks</i>	6 Hubgetriebe	B14
Martinetti UP con vite trapezia - TR	<i>UP screw jacks with trapezoidal screw - TR</i>	UP-Hubgetriebe mit Trapezgewinde - TR	B17
Caratteristiche generali - TR	<i>General characteristics - TR</i>	Allgemeine Merkmale - TR	B18
Prestazioni martinetti - TR	<i>Screw jack performance - TR</i>	Leistung des Hubgetriebes - TR	B19
Dimensioni martinetti - TR	<i>Screw jack dimensions - TR</i>	Abmessungen des Hubgetriebes - TR	B21
Martinetti UP con vite a ricircolo di sfere - VRS	<i>UP ball screw jacks - VRS</i>	UP-Hubgetriebe mit Kugelumlaufspindel - VRS	B23
Caratteristiche generali - VRS	<i>General characteristics - VRS</i>	Allgemeine Merkmale - VRS	B24
Prestazioni martinetti - VRS	<i>Screw jack performance - VRS</i>	Leistung des Hubgetriebes - VRS	B25
Dimensioni martinetti - VRS	<i>Screw jack dimensions - VRS</i>	Abmessungen des Hubgetriebes - VRS	B27

Questa sezione annulla e sostituisce ogni precedente edizione o revisione. Qualora questa sezione non Vi sia giunta in distribuzione controllata, l'aggiornamento dei dati ivi contenuto non è assicurato. **In tal caso la versione più aggiornata è disponibile sul nostro sito internet www.transtecno.com**

This section replaces any previous edition and revision. If you obtained this catalogue other than through controlled distribution channels, the most up to date content is not guaranteed. In this case the latest version is available on our web site www.transtecno.com

Generalità

Il martinetto meccanico permette di trasformare il movimento rotatorio fornito da un motore elettrico, pneumatico, idraulico o perfino manuale in un movimento lineare che consente di effettuare sollevamenti verticali in tiro, in spinta o posizionamenti orizzontali.

La nostra gamma di martinetti meccanici serie UP è stata progettata e realizzata per ottenere semplicità di impiego ed alta affidabilità rendendoli idonei ai più svariati impieghi.

Il loro utilizzo può avvenire singolarmente o in configurazioni composte da più martinetti collegati tra di loro tramite rinvii angolari, alberi di trasmissione e giunti, permettendo la realizzazione di sistemi di sollevamento ed azionamenti perfettamente bilanciati anche con carichi non uniformemente distribuiti.

Possono essere utilizzati per sollevare, tirare, spostare, allineare qualsiasi tipo di carico con perfetto sincronismo, cosa difficile da ottenere con altri tipi di movimentazioni.

Possono essere applicati sia con montaggi verticali rivolti verso l'alto o il basso, che in montaggi orizzontali. La nostra gamma standard prevede 6 taglie con carichi da 2.5 a 100 kN.

Sono previsti due rapporti di riduzione standard che variano in funzione della taglia e del passo della vite trapezoidale per garantire sempre la stessa velocità di traslazione per tutte le taglie.

General

The screw jack makes it possible to transform the rotary motion provided by an electric, pneumatic, or hydraulic motor or even a handwheel, into linear motion that allows push or pull vertical lifting and horizontal positioning.

Our range of UP series screw jacks is designed and built to provide ease of use and high reliability, making them suitable for a broad range of applications.

They can be used individually or in configurations composed of multiple jacks connected together by means of bevel gearboxes, drive shafts and couplings, allowing the creation of perfectly balanced lifting systems and drives even with unevenly distributed loads.

They can be used to lift, pull, move, or align any type of load with perfect synchronism, which is difficult to achieve with other types of actuators.

They can be applied either with vertical mountings facing up or down, or with horizontal mountings. Our standard range includes 6 sizes with load capacities from 2.5 to 100 kN.

There are two standard reduction ratios that vary according to the size and pitch of the trapezoidal screw so that the same travel speed can be guaranteed for all sizes.

Allgemeine Informationen

Ein mechanisches Spindelhubgetriebe ermöglicht es, die durch einen elektrischen, pneumatischen, hydraulischen oder sogar handbedienten Antrieb erzeugte Drehbewegung in eine lineare Bewegung umzuwandeln, in dem vertikalen Zug- oder Hubbewegungen und horizontale Bewegungen ausgeführt werden können.

Unsere mechanischen Spindelhubgetriebe der Serie UP wurden für eine einfache Anwendung und hohe Zuverlässigkeit entwickelt und gefertigt und eignen sich für die unterschiedlichsten Anwendungsgebiete. Sie können sowohl einzeln als auch in Kombination mit mehreren Spindelhubgetrieben über Kegelradgetriebe, Kupplungswellen oder Kupplungen miteinander verbundenen und verwendet werden. Dadurch lassen sich Hebe- und Antriebssysteme umsetzen, die auch mit ungleich verteilten Lasten perfekt ausgegogen arbeiten.

Mit ihnen lassen sich alle Arten von Lasten perfekt synchron heben, ziehen, versetzen oder ausrichten, was sich mit anderen Antriebsarten nur schwer erreichen lässt. Sie können sowohl vertikal nach oben oder unten gerichtet als auch horizontal montiert werden. Unser Standard-Sortiment umfasst 6 Größen mit Lastkapazitäten zwischen 2,5 bis 100 kN.

Es gibt zwei Standardübersetzungen, die je nach Größe und Hub des Trapezgewindeschafes unterschiedlichen Aufgaben dienen, um immer dieselbe Versetzungsgeschwindigkeit für alle Größen zu garantieren.

Caratteristiche tecniche

- Carter in alluminio per le taglie 2.5 - 5 - 10 - 25
- Carter in ghisa per le taglie 50 e 100
- Vite senza fine in acciaio cementato e temprato
- Ruota elicoidale in bronzo
- Stelo filettato in acciaio al carbonio con filettatura destra
- Madrevite rotanti in bronzo

Technical characteristics

- Aluminium casing for sizes 2.5 - 5 - 10 - 25
- Cast iron casing for sizes 50 and 100
- Hardened and case-hardened steel worm screw
- Bronze worm wheel
- Threaded carbon steel rod with right-hand threading
- Bronze rotating lead screws

Technische Daten

- Aluminiumgehäuse für die Größen 2.5 - 5 - 10 - 25
- Gussgehäuse für die Größen 50 und 100
- Zementierte und gehärtete Stahlschnecke
- Schneckenrad aus Bronze
- Gewindestange aus Kohlenstoffstahl mit Rechtsgewinde
- Drehbare Mutter aus Bronze

Codice d'ordinazione

Order code

Bestellcode

1	2	3	4	5	6	7	8	9	10
Taglia Size Größe	Tipo Type Typ	Versione Version Ausführung	Rapp. di riduzione Reduction ratio Verhältnis der Untersetzung	Vite Screw Spindel	Corsa Stroke Hub	Motore Motor Motor	Terminale Front fixing Endstück	Accessori Accessories Zubehör	Speciale Special Spezial
UP2,5	T	A	N	TR 18 X 4	150	...	TE	B	-

- UP2,5
- UP5
- UP10
- UP25
- UP50
- UP100

T	Traslante Travelling Stehend
R	Rotante Rotating Rotierend

- N
- L

- 16x4
- 18x4
- 20x4
- 30x6
- 40x7
- 55x9
- 16x5
- 20x5
- 32x10
- 40x10
- 50x10

Personalizzata
Customised
Personalisiert

Corsa standard / Standard stroke / Standardhub
Corsa minima 50 mm con incrementi di 50 mm
Minimum stroke 50 mm in increments of 50 mm
Mindesthub 50 mm, Extension in Schritten von 50 mm

A	Vite bisporgente versione standard 2'shaft standard version Doppelspindel in Standardausführung
B	Vite monoalbero montaggio sx 1'shaft -left assembly Einfache Spindel für Montage li
C	Vite monoalbero montaggio dx 1'shaft-right assembly Einfache Spindel für Montage re
D	Vite bisporgente + flangia motore e giunto montaggio sx (senza motore specificare flangia motore) 2'shaft with motor flange and coupling-left assembly (without motor specify flange type) Doppelte Spindel + Motorflansch und Kupplung für Montage li (wenn ohne Motor, bitte Motorflansch angeben)
E	Vite bisporgente + flangia motore e giunto montaggio dx (senza motore specificare flangia motore) 2'shaft with motor flange and coupling-right assembly (without motor specify flange type) Doppelte Spindel + Motorflansch und Kupplung für Montage re (wenn ohne Motor, bitte Motorflansch angeben)
F	Vite monoalbero + flangia motore e giunto montaggio sx (senza motore specificare flangia motore) 1'shaft with motor flange and coupling-left assembly (without motor specify flange type) Einfache Spindel + Motorflansch und Kupplung für Montage li (wenn ohne Motor, bitte Motorflansch angeben)
G	Vite monoalbero + flangia motore e giunto montaggio dx (senza motore specificare flangia motore) 1'shaft with motor flange and coupling-right assembly (without motor specify flange type) Einfache Spindel + Motorflansch und Kupplung für Montage re (wenn ohne Motor, bitte Motorflansch angeben)

TE	Terminale filettato (standard per tipo T) Treaded end (standard for type T) Gewinde-Endstück (Standard für Typ T)
PE	Terminale oscillante Pivot bearing end Schwenklagerkopf
FF	Piattello di fissaggio Fixing Flanged Befestigungsflansch
RE	Testa a snodo Rod end Kugelgelenkkopf
FE	Forcella Forked end Gabelkopf
CE	Estremità cilindrica (standard per tipo R) Cylindrical end (standard for type R) Zylindrisches Ende (Standard für Typ R)
SE	Terminale speciale Special end Spezialendstück

SN-R	Chiocciola di sicurezza (UP-R) Safety Nuts (UP-R) Sicherheitsfangmutter (UP-R)
SN-T	Chiocciola di sicurezza vers. UP-T Safety Nuts UP-T version Sicherheitsfangmutter Vers. UP-T
IS	Stelo maggiorato UP-R Increased size screw UP-R Verlängerter Schaft UP-R
FS	Listelli di fissaggio Fastening strips Befestigungsleisten
PBP	Piastre supporto oscillante Pivot bearing plate Schwenklagerplatte
2PLS-1	N° 2 Fine corsa induttivi pos.1 N° 2 Proximity (Inductive) sensors pos. 1
2PLS-2	N° 2 Fine corsa induttivi pos.2 N° 2 Proximity (Inductive) sensors pos. 2
2PLS-3	N° 2 Fine corsa induttivi pos.3 N° 2 Proximity (Inductive) sensors pos. 3
2PLS-4	N° 2 Fine corsa induttivi pos.4 N° 2 Proximity (Inductive) sensors pos. 4
2MLS	N° 2 Fine corsa magnetici N° 2 Magnetic limit switches 2 magnetische Endscharter
3MLS	N° 3 Fine corsa magnetici N° 3 Magnetic limit switches 3 magnetische Endscharter
2MS-1	N° 2 Fine corsa meccanici pos.1 N° 2 Mechanical limit switches pos. 1
2MS-2	N° 2 Fine corsa meccanici pos.2 N° 2 Mechanical limit switches pos. 2
2MS-3	N° 2 Fine corsa meccanici pos.3 N° 2 Mechanical limit switches pos. 3
2MS-4	N° 2 Fine corsa meccanici pos.4 N° 2 Mechanical limit switches pos. 4
B	Soffietto Bellows Faltenbalg
AD	Antirotrazione (solo UP-T) Antirotration Device (UP-T only) Verdrehsicherung (nur UP-T)
EP	Protezione antisfilamento Escape protection Ausdrehsicherung
SSV	Versione inox Stainless steel version Edelstahlausführung
H	Volantino Handwheel Handrad
VS	Guarnizioni in viton Viton seals Viton-Dichtungen
SS	Guarnizioni in silicone Silicone seals Silikon-Dichtungen

* Per versioni speciali indicare il numero di disegno
For special versions please indicate the drawing number
Bei Sonderausführungen bitte die Zeichnungsnummer angeben



Versione	Version	Ausführung
A - Vite bisporgente versione standard	A - <i>Double extension screw standard version</i>	A - Doppelspindel in Standardausführung
B - Vite monoalbero montaggio sx	B - <i>Single spindle screw Lh assembly</i>	B - Einfache Spindel für Montage li
C - Vite monoalbero montaggio dx	C - <i>Single spindle screw Rh assembly</i>	C - Einfache Spindel für Montage re
D - Vite bisporgente + flangia motore e giunto montaggio sx	D - <i>Double extension screw + drive flange and coupling Lh assembly</i>	D - Doppelspindel + Motorflansch und Kupplung für Montage li
E - Vite bisporgente + flangia motore e giunto montaggio dx	E - <i>Double extension screw + drive flange and coupling Rh assembly</i>	E - Doppelspindel + Motorflansch und Kupplung für Montage re
F - Vite monoalbero + flangia motore e giunto montaggio sx	F - <i>Single spindle screw + drive flange and coupling Lh assembly</i>	F - Einfache Spindel + Motorflansch und Kupplung für Montage li
G - Vite monoalbero + flangia motore e giunto montaggio dx	G - <i>Single spindle screw + drive flange and coupling Rh assembly</i>	G - Einfache Spindel + Motorflansch und Kupplung für Montage re

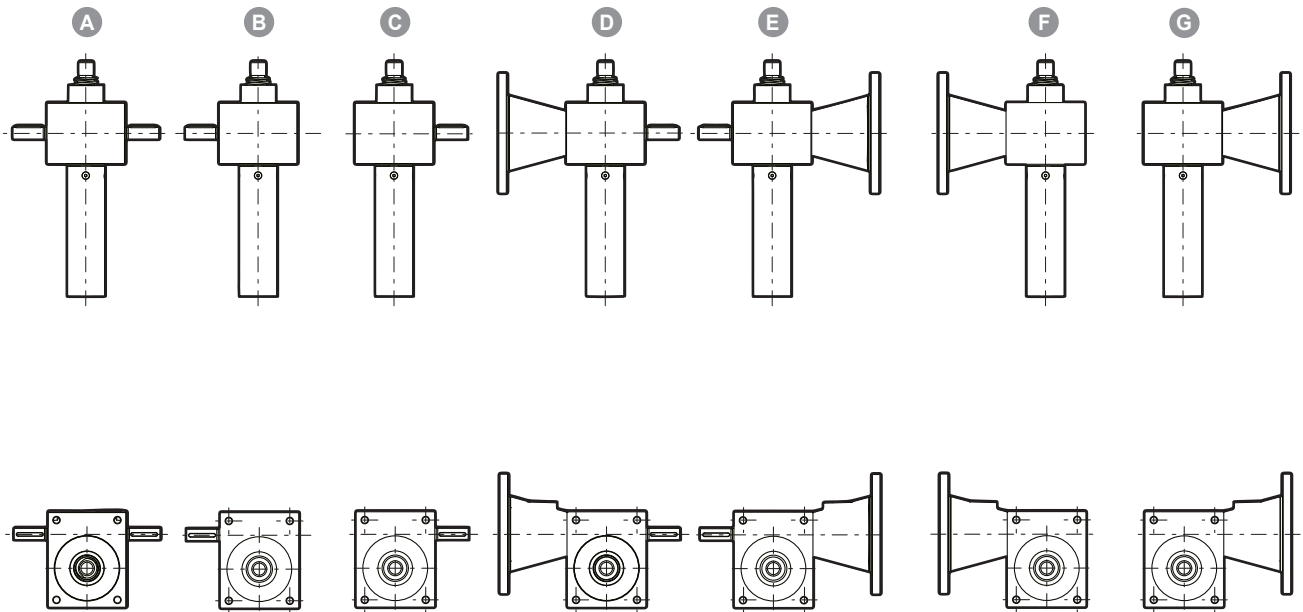

Motori applicabili e flangia motore *Applicable motors and motor flange* **Geeignete Motoren und Motorflansche**

Taglia UP / UP size / Größe UP	Flangia motore IEC / IEC motor flange / Motorflansch IEC	N	M	P	D	L
UP2.5	56B14	50	65	80	9	55
	63B14	60	75	80	11	55
UP5	56B5	80	100	120	9	57
	63B5	95	115	140	11	60
	71B5	110	130	160	14	65
UP10	63B5	95	115	140	11	75
	71B5	110	130	160	14	80
	80B5	130	165	200	19	90
UP25	71B5	110	130	160	14	90
	80B5	130	165	200	19	105
	90B5	130	165	200	24	105
UP50	80B5	130	165	200	19	112
	90B5	130	165	200	24	112
	100/112B5	180	215	250	28	125
UP100	90B5	130	165	200	24	127
	100/112B5	180	215	250	28	140
	132B5	230	265	300	38	175

UP

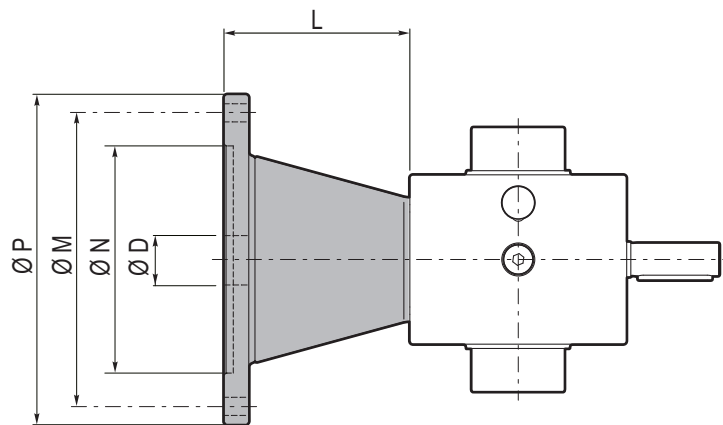

Lubrificazione e pesi

Lubrication and weights

Schmierung und Gewichte

LUBRIFICAZIONE RIDUTTORE MARTINETTO

Il gruppo riduttore è riempito con un grasso liquido sintetico di alta qualità che ne garantisce in condizioni normali la lubrificazione a vita. A richiesta è disponibile la versione lubrificata ad olio.

JACK GEARBOX LUBRICATION

The gearbox is filled with high-quality synthetic liquid grease that guarantees lifetime lubrication under normal conditions. An oil lubricated version is available on request.

SCHMIERUNG DES SPINDELHUBGETRIEBES

Die Getriebe sind mit einem hochwertigen synthetischen Flüssigfett gefüllt, die unter normalen Betriebsbedingungen eine lebenslange Schmierung gewährleistet. Auf Wunsch sind auch Ausführungen mit Ölschmierung erhältlich.

LUBRIFICAZIONE STELO FILETTATO

Il sistema di lubrificazione presente sulla versione traslante permette di lubrificare lo stelo durante il funzionamento garantendo la distribuzione del grasso su tutta la sua lunghezza.

Per la versione rotante a richiesta possono essere fornite chiocciole con ingrassatore.

SCREW SPINDLE LUBRICATION

The lubrication system on the travelling version allows lubrication of the spindle during operation, ensuring the distribution of grease over its entire length.

For the rotary version, nuts can be supplied with a grease nipple on request.

SCHMIERUNG DES GEWINDESCHAFTES

Das bei den stehenden Ausführungen verwendete Schmiersystem ermöglicht eine Schmierung des Schaftes während des Betriebs, wodurch eine gleichmäßige Schmierfettverteilung über die gesamte Länge sichergestellt wird.

Für die rotierenden Ausführungen können auf Wunsch Muttern mit Schmiernippeln geliefert werden.

ATTENZIONE! La lubrificazione dello stelo filettato è a cura dell'utilizzatore finale.

Fare riferimento alle indicazioni riportate a pag. A6

IMPORTANT! Lubrication of the threaded piston rod is the responsibility of the end user. Please refer to the instructions on page A6.

ACHTUNG! Die Schmierung des Gewindeschafes obliegt der Verantwortung des Endnutzers. Siehe Seite A6.

QUANTITA' D'OLIO E PESI

OIL QUANTITY AND WEIGHTS

ÖLMENGE UND GEWICHTE

Versione / Versione / Ausführung																								
Tipo / Type / Typ	UP2.5		UP5		UP10		UP25		UP50		UP100													
	TR	VRS	TR	VRS	TR	VRS	TR	VRS	TR	VRS	TR	VRS												
Peso del martinetto senza corsa. Jack weight (gearbox only) Maximal zulässiges Drehmoment an der Spindel	T	R	R	T	R	R	T	R	R	T	R	T	R	T	R	T	R	T	R	T	R			
[kg]	0.82	1.1	1.1	1.6	1.8	1.8	2.8	3.16	3.16	5.7	6	5.7	6.3	20.3	22.1	20.3	22.2	37.4	40.3	37.4	40.2			
Peso per ogni 100 mm di corsa. Weight of spindle each 100 mm stroke Gewicht pro 100 mm Hub	T	R	R	T	R	R	T	R	R	T	R	T	R	T	R	T	R	T	R	T	R			
[kg]	0.16	0.12	0.12	0.22	0.15	0.2	0.27	0.19	0.2	0.62	0.44	0.75	0.56	1	0.8	1	0.83	2	1.55	1.8	1.35			
Lubrificazione del riduttore Lubrication within gearbox Getriebeschmierung	0.02		0.02		0.03		0.03		0.05		0.05		0.1		0.1		0.3		0.3		0.4		0.4	

NB: I pesi sono indicativi e cambiano in funzione della configurazione e della flangia motore.

NB: Weights are indicative and vary according to the configuration and motor flange.

NB: Die Gewichte sind Richtwerte und ändern sich je nach Konfiguration und Motorflansch.

Temperatura e fattore di servizio

Temperature and service factor

Temperatur und Betriebsfaktor

I martinetti con vite trapezia non sono idonei per il funzionamento continuo, mentre i martinetti con viti a ricircolo di sfere sono idonei per il funzionamento continuo.

Screw jacks with trapezoidal screws are not suitable for continuous operation, whereas ball screw jacks are suitable for continuous operation.

Hubgetriebe mit Trapezgewindespindeln sind nicht für den Dauerbetrieb geeignet, während Hubgetriebe mit Kugelumlaufspindeln für den Dauerbetrieb geeignet sind.

Le prestazioni riportate nelle tabelle sono riferite ad un fattore di servizio 20% su 60 min. ad una temperatura ambiente di 20°C. Per i martinetti con vite a ricircolo di sfere è possibile lavorare in modo continuativo.

The performances shown in the tables refer to a service factor of 20% over 60 min. at an ambient temperature of 20°C. For ball screw jacks, continuous operation is possible.

Die in den Tabellen angegebenen Leistungen beziehen sich auf einen Betriebsfaktor von 20% über 60 Minuten bei einer Umgebungstemperatur von 20°C. Bei Hubgetrieben mit Kugelumlaufspindeln ist ein Dauerbetrieb möglich.

L'intervallo di temperatura d'esercizio non deve superare -10°C + 60°C (riduttore) -10°C + 80°C le viti trapezie.

The operating temperature range must not exceed -10°C + 60°C (gearbox) -10°C + 80°C the trapezoidal screws. In borderline cases, choose a larger jack or for different service factors or temperatures contact our technical service.

Der Betriebstemperaturbereich darf -10°C + 60°C (Getriebe) -10°C + 80°C (Trapezgewinde) nicht überschreiten. In Grenzfällen wählen Sie ein größeres Hubgetriebe oder wenden Sie sich bei abweichenden Betriebsfaktoren und Temperaturen an unseren technischen Dienst.

In casi limite, scegliere un martinetto di dimensioni maggiori oppure per fattori di servizio diversi o temperature diverse contattare il nostro servizio tecnico.

For temperature ranges other than those indicated above, the jack must be fitted with special seals (optional on request).

Für andere als die oben angegebenen Temperaturbereiche muss das Hubgetriebe mit speziellen Dichtungen ausgestattet werden (optional auf Anfrage).

Temperatura d'esercizio / Operating temperature / Betriebstemperatur			
≤ -10°C		> 60°C	
Paraoli in silicone / Silicone oil seals / Silikon-Öldichtungen	SS	Paraoli in Viton / Viton oil seals / Viton-Öldichtungen	VS
Basse temperature / Low temperatures / Niedrige Temperaturen		Alte temperature / High temperatures / Hohe Temperaturen	

Irreversibilità / reversibilità

In linea di massima i martinetti con viti trapezoidali ad un principio hanno una buona irreversibilità.

L'inerzia del sistema può variare a seconda dell'applicazione e può essere eliminata con l'utilizzo di un freno meccanico.

Il freno è consigliato anche nelle applicazioni ove sono presenti sollecitazioni d'urto o forti vibrazioni.

I martinetti con steli trapezoidali a due principi o a ricircolo di sfere sono reversibili ed è necessario utilizzare un freno meccanico.

Irreversibility / Reversibility

In principle, jacks with single-start trapezoidal screws offer a high level of irreversibility. System inertia can vary depending on the application and can be eliminated by using a mechanical brake.

A brake is also recommended in applications characterised by shock loads or strong vibrations.

Jacks with double-start trapezoidal spindles or ball screws are reversible and a mechanical brake is necessary.

Nichtumkehrbarkeit / Umkehrbarkeit

Grundsätzlich haben die Spindelhubgetriebe mit einfachem Trapezgewinde eine Selbsthemmung.

Die Trägheit des Systems kann jedoch je nach Anwendung variieren und kann mit einer mechanischen Bremse aufgehoben werden.

Eine Bremse ist auch bei Anwendungen empfehlenswert, die Stoßbelastungen oder starken Vibrationen ausgesetzt sind.

Die Spindelhubgetriebe mit Doppel-Trapezgewinde oder mit Kugelumlaufspindel sind umkehrbar und benötigen auf jeden Fall eine mechanische Bremse.

Direzione di rotazione e di movimento

I martinetti standard montano viti senza fine destre e steli destri. Nella figura sono riportati i sensi di rotazione e i rispettivi movimenti lineari.

Rotation and movement direction

Standard jacks are fitted with right-hand worm screws and right-hand spindles. The figure shows the rotation directions and the respective linear movements.

Dreh- Und Bewegungsrichtung

Die Standard-Spindelhubgetriebe verfügen über Gewindespindeln mit Rechtsgewinde. Die Abbildung zeigt die Drehrichtungen und die entsprechenden Linearbewegungen.

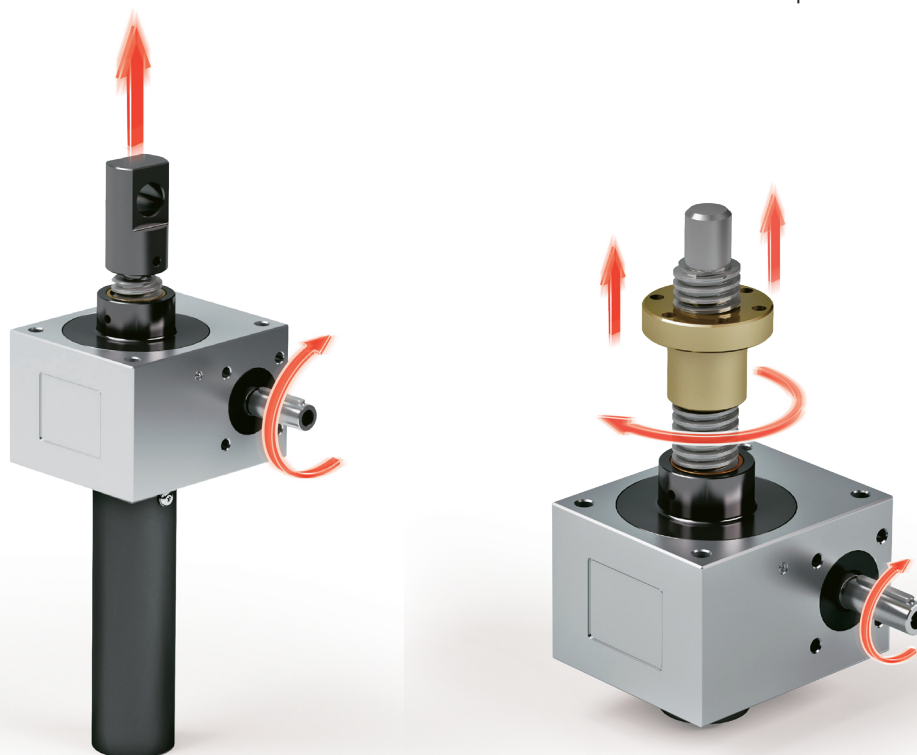

Sensi di rotazione sistemi multipli

Nella realizzazione di un sistema a più martinetti, occorre fare attenzione alla direzione di rotazione dell'impianto.

Si consiglia di consultare i nostri schemi di montaggio standard.

In caso di rinvii angolari a 3 vie, la direzione di rotazione può essere modificata grazie alla semplice rotazione del rinvio stesso.

Multiple System Rotation Directions

When creating a multi-jack system, pay attention to the system's rotation direction.

We recommend consulting our standard assembly diagrams.

In the case of 3-way bevel gearboxes, the direction of rotation can be changed simply by rotating the gearbox.

Drehrichtung Von Mehrfachsystemen

Beim Bau von Systemen mit mehreren Spindelhubgetrieben muss auf die Drehrichtung der Anlage geachtet werden.

Konsultieren Sie diesbezüglich unsere Standard-Montageschemata.

Bei 3-Wege-Kegelradgetrieben kann die Drehrichtung durch einfaches Drehen des gesamten Gewindes geändert werden.

Schemi di montaggio

Assembly diagrams

Montageschemata

Legenda
Legend
Legende

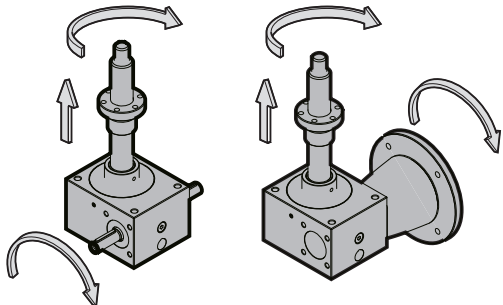

Martinetto
Screwjack
Hubgetriebe

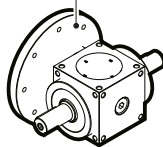
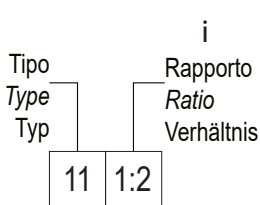

Rinvio Angolare (Consultare il catalogo serie QB)
Bevel gear (Consult the QB series catalog)
Kegelradgetriebe (siehe Katalog der Serie QB)

1:1
 1:1,5 Rapporti Disponibili
 1:2 Available Ratios
 1:3 Verfügbare Untersetzungsverhältnisse
 1:4

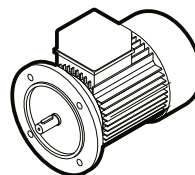

Motore
Motor
Motor

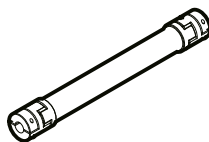

Albero di trasmissione
Transmission Shaft
Verbindungswelle



Giunto
Coupling
Kupplung

A B C D E F G

ORIENTAMENTO FLANGIA MOTORE E ALBERI (vedi pag. B6)
DRIVE FLANGE AND SHAFTS ORIENTATION (see page B6)
AUSRICHTUNG VON MOTORFLANSCH UND WELLEN (siehe Seite B6)

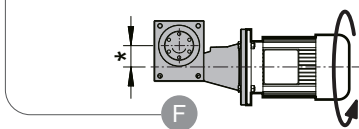

NOTA: La quota "*" varia in funzione della taglia del martinetto / rinvio

NOTE: Dimension "*" varies according to the size of the jack/reverse unit

HINWEIS: Das Maß "*" variiert je nach Größe des Hubgetriebe / der Umlenkung

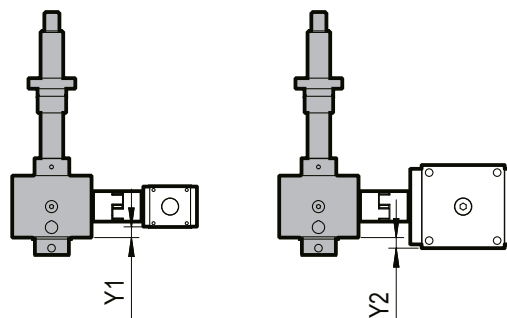

NOTA: Le quote Y1 e Y2 di altezza tra martinetto e rinvio possono avere differenti misure in funzione dei modelli di rinvio utilizzato.

NOTE: The amounts Y1 and Y2 being the height of the jack and gear may have different measurements depending on the gear models used.

HINWEIS: Die Höhenunterschiede Y1 und Y2 zwischen Spindelhubgetriebe und Kegelradgetriebe hängen von dem verwendeten Kegelradgetriebe Modell ab

Schemi di montaggio
2 martinetti

Assembly diagrams
2 screwjacks

Montageschemata
2 Spindelhubgetriebe

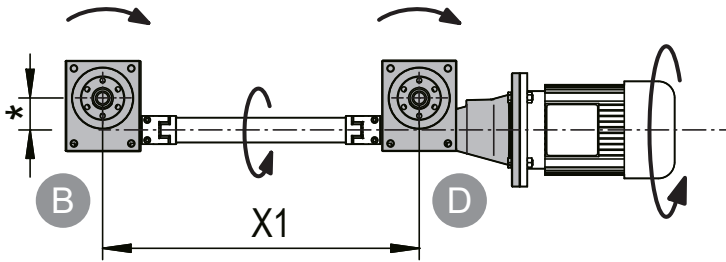

		2.A	
Rendimento del sistema Overall System Efficiency Wirkungsgrad des Konfiguration	η_c	0.95	
Versione martinetto Screwjacks version Hubgetriebe-version		Qty	
B		1	
D		1	

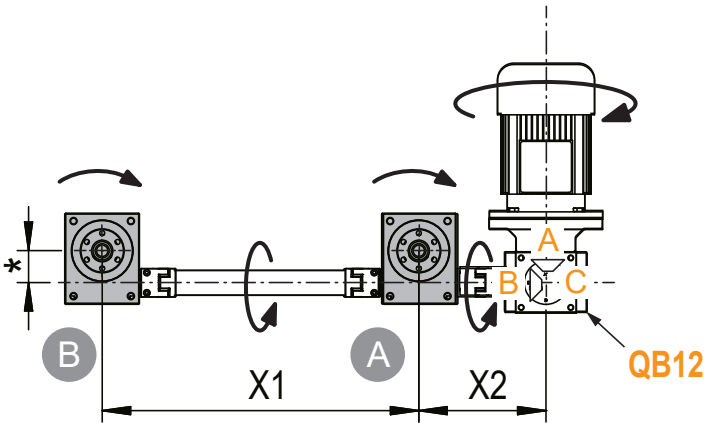

		2.B	
Rendimento del sistema Overall System Efficiency Wirkungsgrad des Konfiguration	η_c	0.90	
Versione martinetto Screwjacks version Hubgetriebe-version		Qty	
A		1	
B		1	
Rinvio angolare Right angle Kegelradgetriebe	i	Qty	
QB12	All	1	

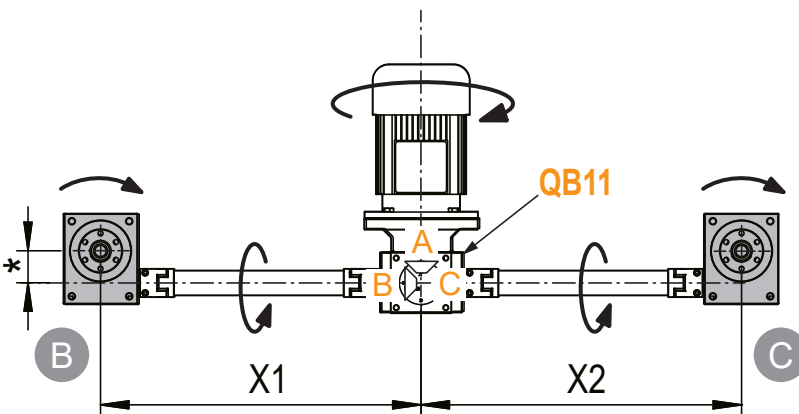

		2.C	
Rendimento del sistema Overall System Efficiency Wirkungsgrad des Konfiguration	η_c	0.90	
Versione martinetto Screwjacks version Hubgetriebe-version		Qty	
B		1	
C		1	
Rinvio angolare Right angle Kegelradgetriebe	i	Qty	
QB11	All	1	

Schemi di montaggio
3 martinetti

Assembly diagrams
3 screwjacks

Montageschemata
3 Spindelhubgetriebe

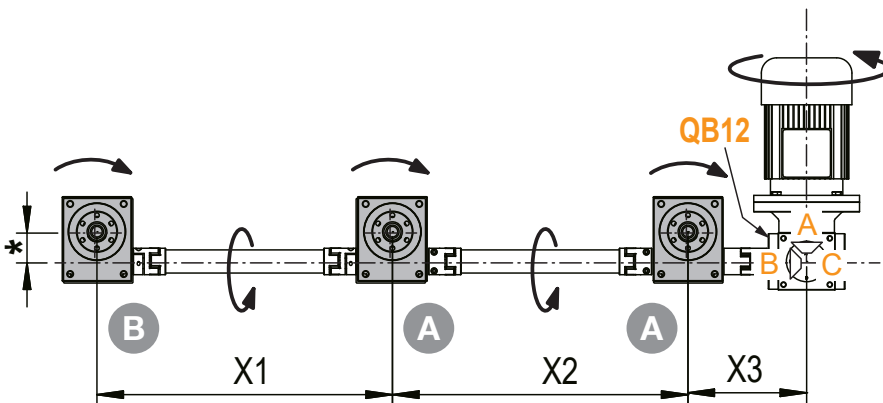
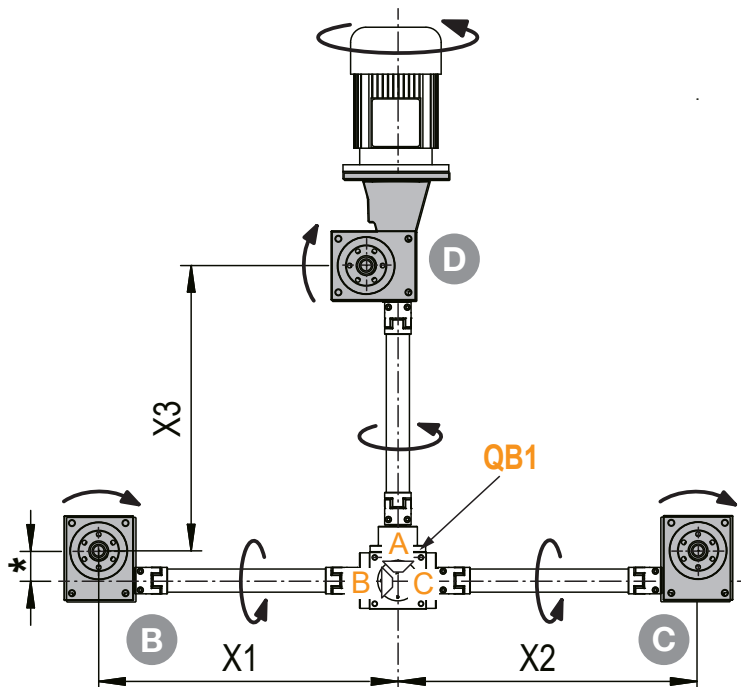
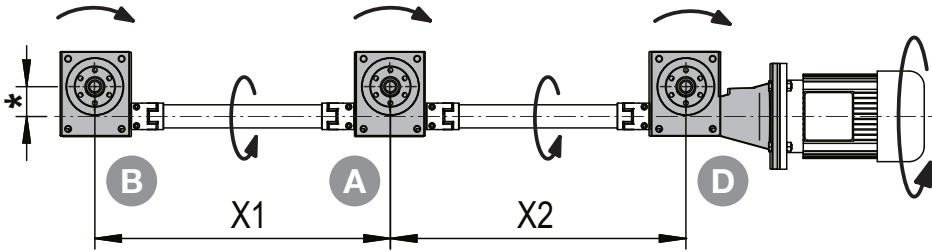

		3.A
Rendimento del sistema Overall System Efficiency Wirkungsgrad des Konfiguration	η_c	0.90
Versione martinetto Screwjacks version Hubgetriebe-version		Qty
	A	1
	B	1
	D	1

		3.B
Rendimento del sistema Overall System Efficiency Wirkungsgrad des Konfiguration	η_c	0.87
Versione martinetto Screwjacks version Hubgetriebe-version		Qty
	B	1
	C	1
	D	1
Rinvio angolare Right angle Kegelradgetriebe	i	Qty
	QB1	All 1

		3.C
Rendimento del sistema Overall System Efficiency Wirkungsgrad des Konfiguration	η_c	0.87
Versione martinetto Screwjacks version Hubgetriebe-version		Qty
	A	2
	B	1
Rinvio angolare Right angle Kegelradgetriebe	i	Qty
	QB12	All 1

Schemi di montaggio
3 martinetti

Assembly diagrams
3 screwjacks

Montageschemata
3 Spindelhubgetriebe

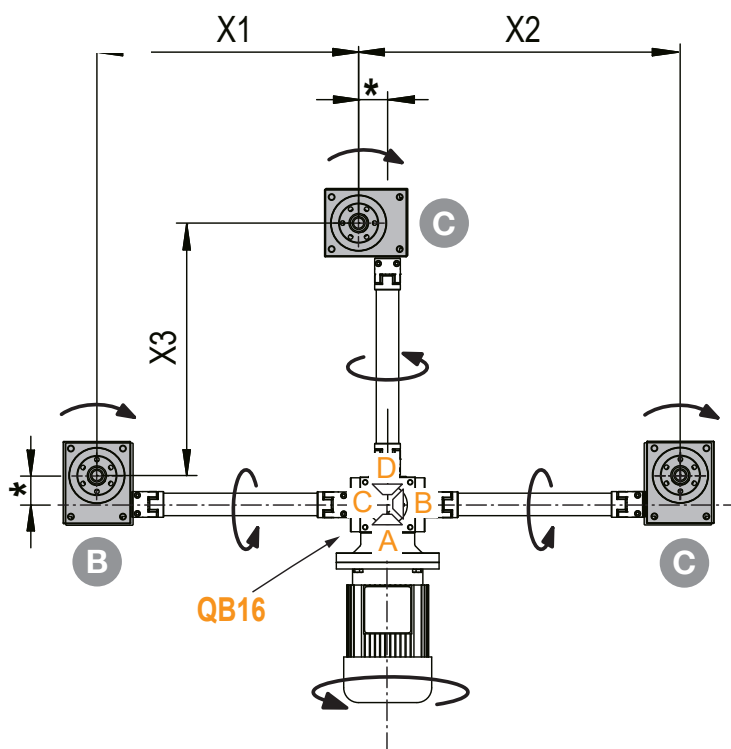
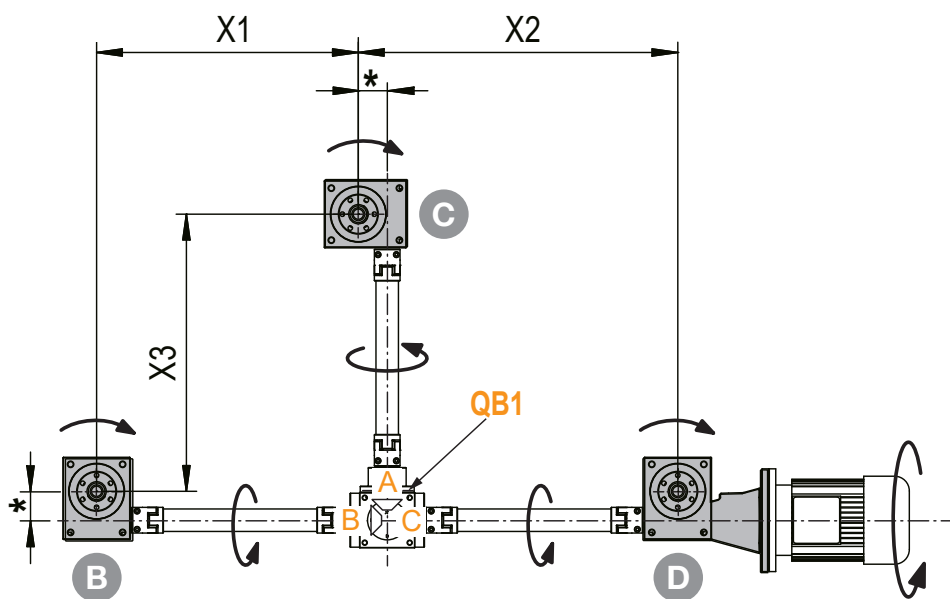
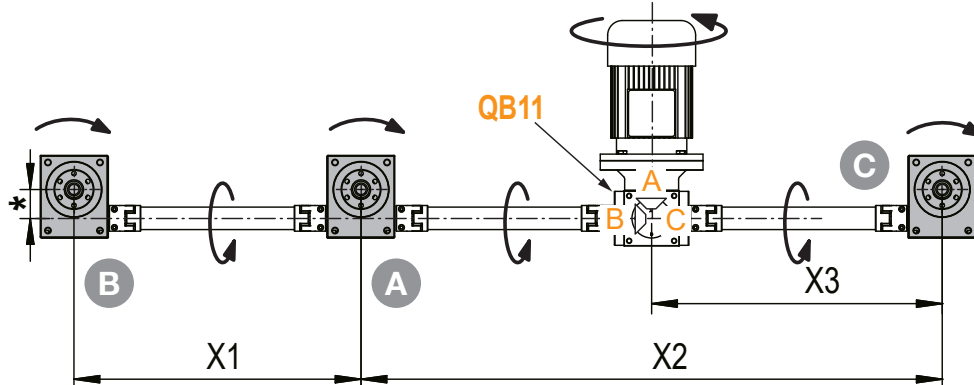

		3.D
Rendimento del sistema Overall System Efficiency Wirkungsgrad des Konfiguration	η_c	0.87
Versione martinetto Screwjacks version Hubgetriebe-version		Qty
A		1
B		1
C		1
Rinvio angolare Right angle Kegelradgetriebe	i	Qty
QB11		All 1

		3.E
Rendimento del sistema Overall System Efficiency Wirkungsgrad des Konfiguration	η_c	0.87
Versione martinetto Screwjacks version Hubgetriebe-version		Qty
B		1
C		1
D		1
Rinvio angolare Right angle Kegelradgetriebe	i	Qty
QB1		1:1 1

		3.F
Rendimento del sistema Overall System Efficiency Wirkungsgrad des Konfiguration	η_c	0.87
Versione martinetto Screwjacks version Hubgetriebe-version		Qty
B		1
C		2
Rinvio angolare Right angle Kegelradgetriebe	i	Qty
QB16		1:1 1

Schemi di montaggio
3 martinetti

Assembly diagrams
3 screwjacks

Montageschemata
3 Spindelhubgetriebe

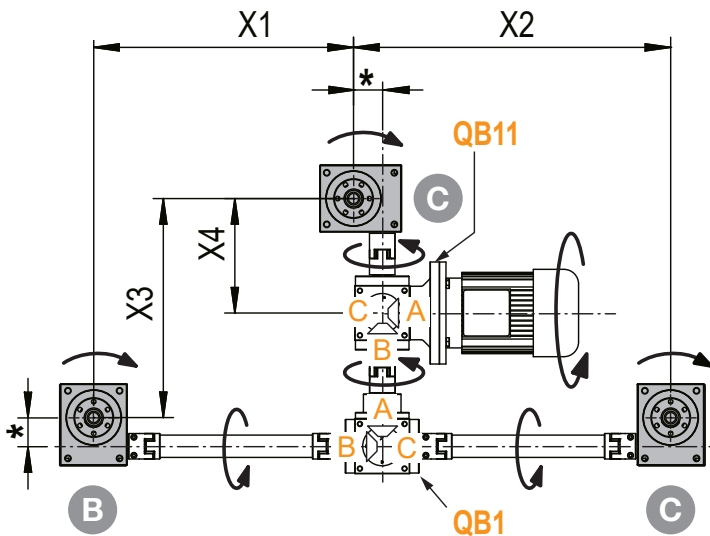

		3.G	
Rendimento del sistema Overall System Efficiency Wirkungsgrad des Konfiguration	η_c	0.87	
Versione martinetto Screwjacks version Hubgetriebe-version		Qty	
B		1	
C		2	
Rinvio angolare Right angle Kegelradgetriebe	i	Qty	
QB11	All	1	
QB1	1:1	1	

Schemi di montaggio
4 martinetti

Assembly diagrams
4 screwjacks

Montageschemata
4 Spindelhubgetriebe

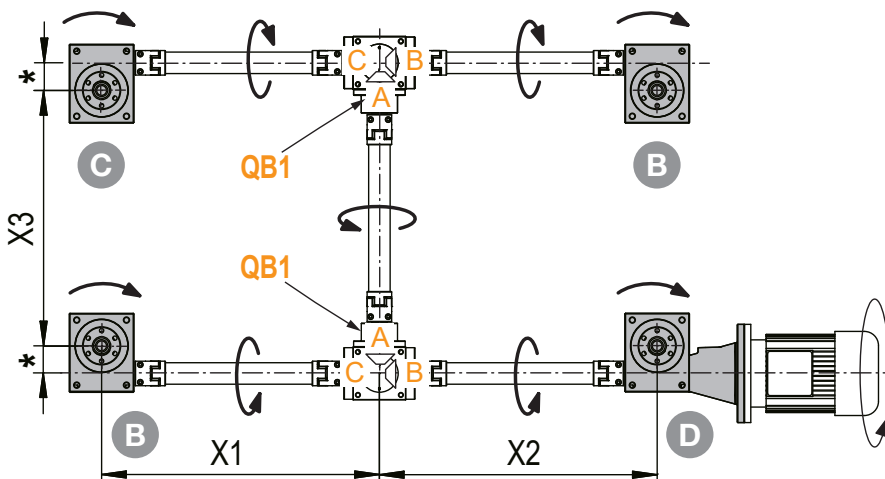

		4.A	
Rendimento del sistema Overall System Efficiency Wirkungsgrad des Konfiguration	η_c	0.80	
Versione martinetto Screwjacks version Hubgetriebe-version		Qty	
B		2	
C		1	
D		1	
Rinvio angolare Right angle Kegelradgetriebe	i	Qty	
QB1	1:1	2	

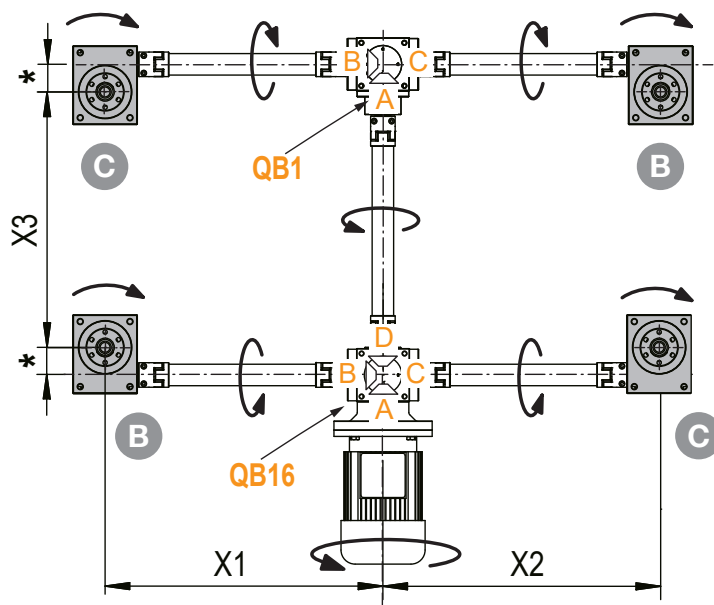

		4.B	
Rendimento del sistema Overall System Efficiency Wirkungsgrad des Konfiguration	η_c	0.80	
Versione martinetto Screwjacks version Hubgetriebe-version		Qty	
B		2	
C		2	
Rinvio angolare Right angle Kegelradgetriebe	i	Qty	
QB1	All	1	
QB16	All	1	

Schemi di montaggio
4 martinetti

Assembly diagrams
4 screwjacks

Montageschemata
4 Spindelhubgetriebe

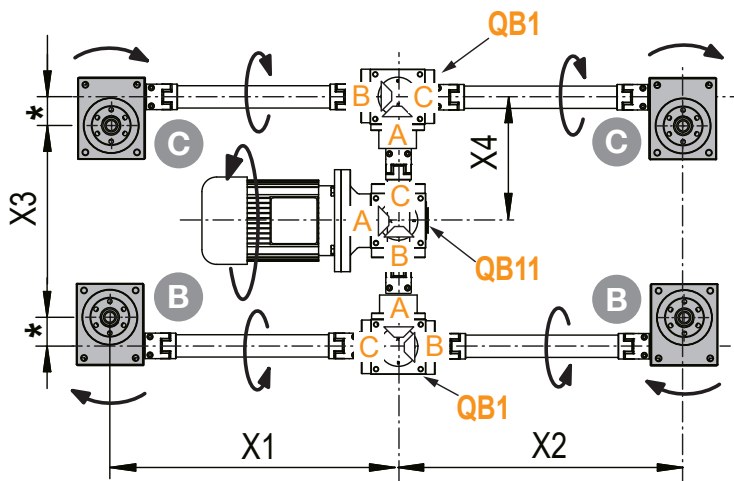
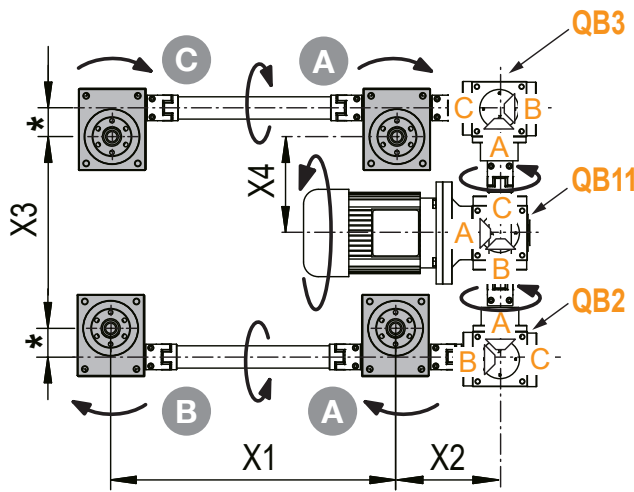
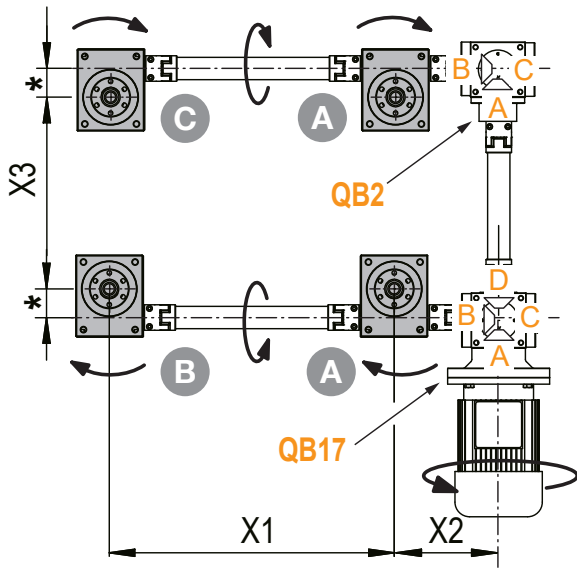

			4.C
Rendimento del sistema Overall System Efficiency Wirkungsgrad des Konfiguration	η_c		0.80
Versione martinetto Screwjacks version Hubgetriebe-version			Qty
	A		1
	B		1
	C		1
Rinvio angolare Right angle Kegelradgetriebe	i	Qty	
	QB17	All	1
	QB2	All	1

			4.D
Rendimento del sistema Overall System Efficiency Wirkungsgrad des Konfiguration	η_c		0.76
Versione martinetto Screwjacks version Hubgetriebe-version			Qty
	A		2
	B		1
	C		1
Rinvio angolare Right angle Kegelradgetriebe	i	Qty	
	QB11	All	1
	QB2	All	1
	QB3	All	1

			4.E
Rendimento del sistema Overall System Efficiency Wirkungsgrad des Konfiguration	η_c		0.76
Versione martinetto Screwjacks version Hubgetriebe-version			Qty
	B		2
	C		2
Rinvio angolare Right angle Kegelradgetriebe	i	Qty	
	QB11	All	1
	QB1	All	1

Schemi di montaggio
6 martinetti

Assembly diagrams
6 screwjacks

Montageschemata
6 Spindelhubgetriebe

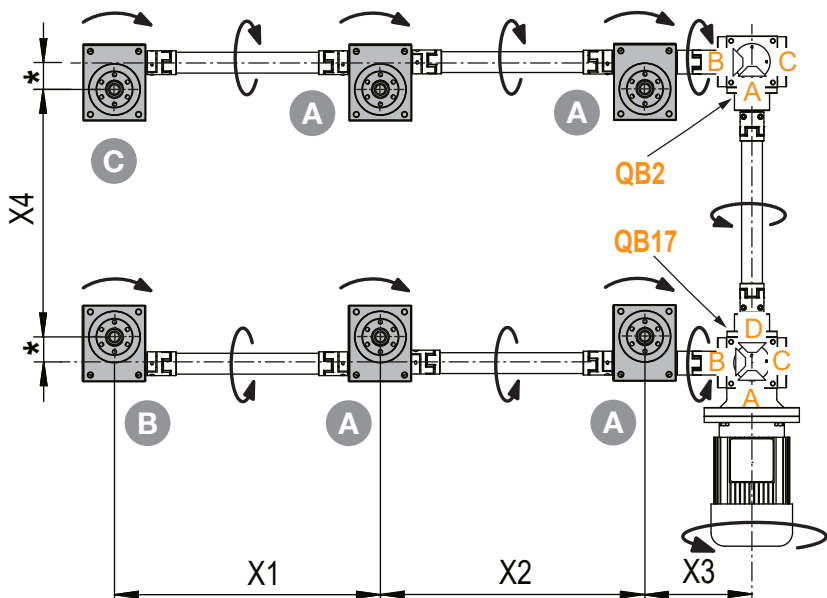
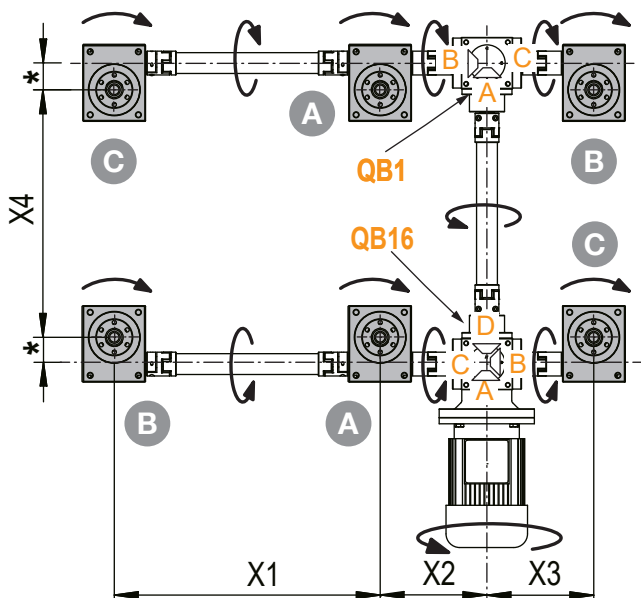
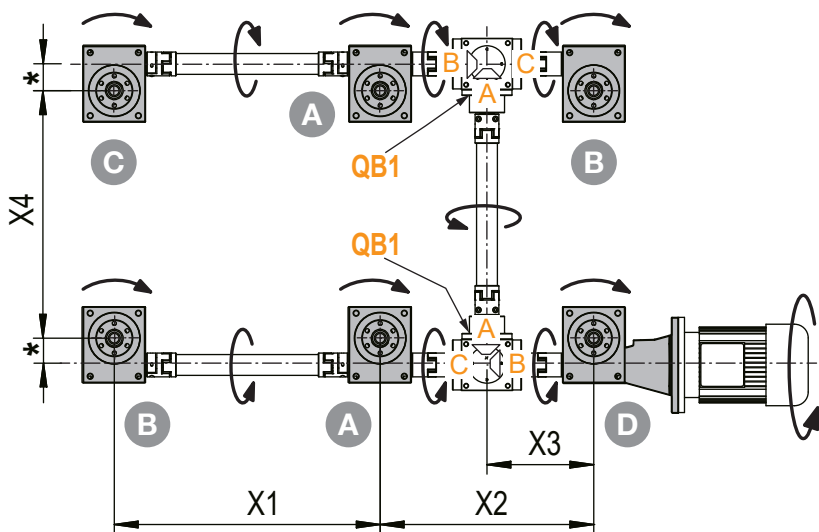

		6.A
Rendimento del sistema Overall System Efficiency Wirkungsgrad des Konfiguration	η_c	0.74
Versione martinetto Screwjacks version Hubgetriebe-version		Qty
	A	2
	B	2
	C	1
	D	1
Rinvio angolare Right angle Kegelradgetriebe	i	Qty
	QB1	1:1 2

		6.B
Rendimento del sistema Overall System Efficiency Wirkungsgrad des Konfiguration	η_c	0.74
Versione martinetto Screwjacks version Hubgetriebe-version		Qty
	A	2
	B	2
	C	2
Rinvio angolare Right angle Kegelradgetriebe	i	Qty
	QB16	All 1
	QB1	All 1

		6.C
Rendimento del sistema Overall System Efficiency Wirkungsgrad des Konfiguration	η_c	0.74
Versione martinetto Screwjacks version Hubgetriebe-version		Qty
	A	4
	B	1
	C	1
Rinvio angolare Right angle Kegelradgetriebe	i	Qty
	QB17	All 1
	QB2	All 1

Schemi di montaggio
6 martinetti

Assembly diagrams
6 screwjacks

Montageschemata
6 Spindelhubgetriebe

6.D $\eta_c = 0,71$

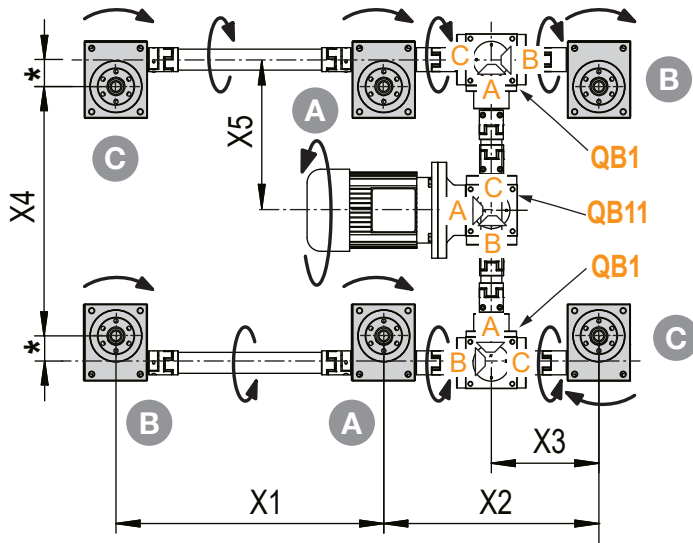

		6.D
Rendimento del sistema Overall System Efficiency Wirkungsgrad des Konfiguration	η_c	0.71
Versione martinetto Screwjacks version Hubgetriebe-version		Qty
	A	2
	B	2
	C	2
Rinvio angolare Right angle Kegelradgetriebe	i	Qty
	QB11	All 1
	QB1	All 2

6.E $\eta_c = 0,71$

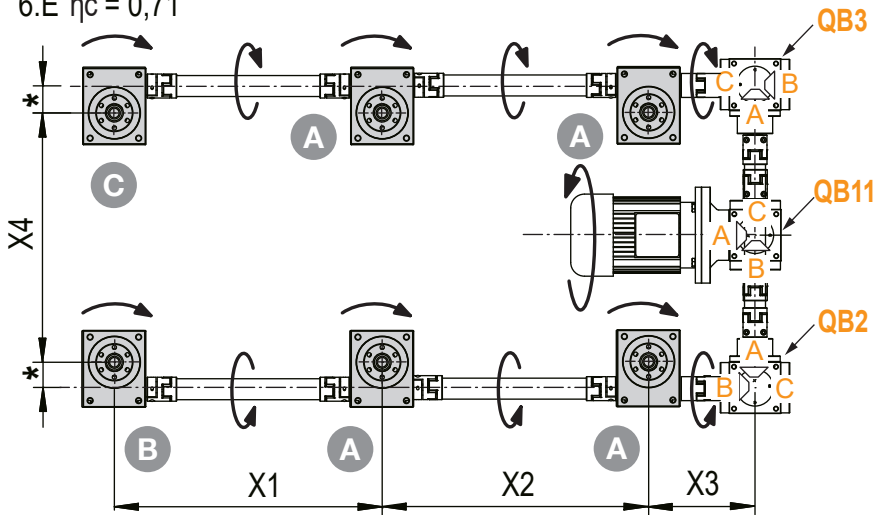

		6.E
Rendimento del sistema Overall System Efficiency Wirkungsgrad des Konfiguration	η_c	0.71
Versione martinetto Screwjacks version Hubgetriebe-version		Qty
	A	4
	B	1
	C	1
Rinvio angolare Right angle Kegelradgetriebe	i	Qty
	QB11	All 1
	QB2	All 1
	QB1	All 1

UP

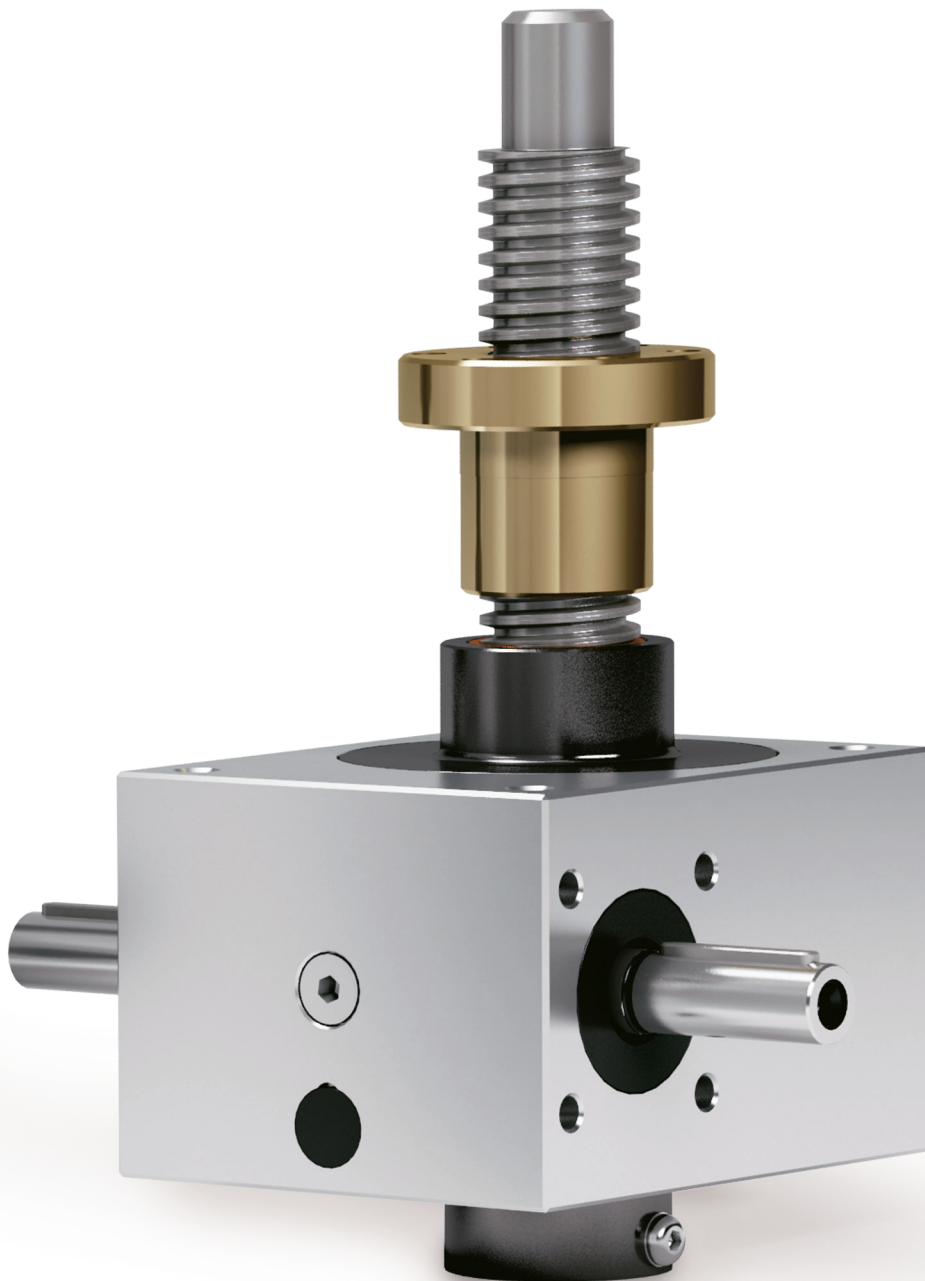

Versione / Versione / Ausführung TR								
Tipo / Type / Typ		UP2,5	UP5	UP10	UP25	UP50	UP100	
Carico statico max in trazione / compressione <i>Max pull / compression static load</i> Maximale statische Zug-/Druckbelastung		[kN]	2.5	5	10	25	50	100
Carico dinamico max. in trazione / compressione <i>Max pull / compression dynamic load</i> Max dynamische Zug-/ Druckbelastung		[kN]	Vedi tabelle prestazioni / See performance tables / Siehe Leistungstabelle					
Vite TR <i>Spindle TR</i> TR-Spindel			16X4	18X4	20X4	30X6	40X7	55X9
Rapporto Normale N <i>Normal ratio N</i> Normales Untersetzungsverhältnis	Rapporto di riduzione normale <i>Normal ratio</i> Normales Untersetzungsverhältnis		1:4	1:4	1:4	1:6	1:7	1:9
	Corsa vite per giro albero ingresso <i>Lead screw stroke per revolution input turn</i> Spindelhub pro Drehung an der Eingangswelle	[mm]	1	1	1	1	1	1
	Rendimento totale del martinetto con rapporto normale <i>Total screw jack efficiency for normal ratio</i> Gesamtwirkungsgrad des Spindelhubgetriebes mit normalem Untersetzungsverhältnis		0.36	0.32	0.30	0.30	0.28	0.24
	Coppia a vuoto * <i>Idling torque</i> Leerlaufmoment	[Nm]	0.08	0.12	0.26	0.36	0.76	1.68
	Coppia max. ammessa sul singolo martinetto. ** <i>Max. permissible torque on the single jack **</i> Maximal zulässiges Drehmoment am einzelnen Spindelhubgetriebe **	[Nm]	1.6	5.0	13.0	20.0	45.0	60.0
Rapporto lento L <i>Slow ratio L</i> Langsames Untersetzungsverhältnis L	Rapporto lento <i>Slow ratio</i> Langsames Untersetzungsverhältnis		1:16	1:16	1:16	1:24	1:28	1:36
	Corsa vite per giro albero ingresso <i>Lead screw stroke per revolution input turn</i> Spindelhub pro Drehung an der Eingangswelle	[mm]	0.25	0.25	0.25	0.25	0.25	0.25
	Rendimento totale del martinetto con rapporto lento <i>Total screw jack efficiency for slow ratio</i> Gesamtwirkungsgrad des Spindelhubgetriebes mit langsamem Untersetzungsverhältnis		0.30	0.27	0.27	0.24	0.24	0.20
	Coppia a vuoto * <i>Idling torque *</i> Leerlaufmoment *	[Nm]	0.06	0.1	0.16	0.26	0.54	1.02
Coppia max. ammessa sul singolo martinetto ** <i>Max. permissible torque on the single jack **</i> Maximal zulässiges Drehmoment am einzelnen Spindelhubgetriebe **	[Nm]	0.5	1.6	3.0	8.0	15.0	19.0	
Coppia max. ammissibile sulla vite senza fine <i>Max permissible torque at worm shaft</i> Maximal zulässiges Drehmoment an der Spindel		[Nm]	10	16	38	63	130	265

* Il valore riportato in tabella è da considerarsi dopo la fase di rodaggio.

** Il valore è riferito alla coppia massima ammessa sulla vite per sistemi a più martinetti.

* The value shown in the table is to be considered after the running-in phase.

** The value refers to the maximum allowed torque on the screw for multiple-jack systems.

* Der in der Tabelle angegebene Wert gilt nach der Einlaufphase.

** Der Wert bezieht sich auf das maximal zulässige Drehmoment an der Spindel für Systeme mit mehreren Spindelhubgetrieben.

Prestazioni martinetti - TR

Jack performance - TR

Leistung der Hubgetriebe - TR

Rapporto / Ratio / Verhältnis		UP2.5 TR 16x4										2500 N	
		Carico / Load / Last [kN]		2.5		2		1.5		1		0.5	
		nn1 giri/min rpm U/mi	Velocità Speed Geschwindigkeit [mm/s]	Pi [kW]	Mt [Nm]	Pi [kW]	Mt [Nm]	Pi [kW]	Mt [Nm]	Pi [kW]	Mt [Nm]	Pi [kW]	Mt [Nm]
N	1500	25.0	0.19	1.2	0.14	0.9	0.1	0.74	0.1	0.52	0.1	0.3	
	1000	16.7	0.13	1.2	0.1	0.9	0.1	0.74	0.1	0.52	0.1	0.3	
	750	12.5	0.1	1.2	0.1	0.9	0.1	0.74	0.1	0.52	0.1	0.3	
	500	8.3	0.1	1.2	0.1	0.9	0.1	0.74	0.1	0.52	0.1	0.3	
	300	5.0	0.1	1.2	0.1	0.9	0.1	0.74	0.1	0.52	0.1	0.3	
	100	1.7	0.1	1.2	0.1	0.9	0.1	0.74	0.1	0.52	0.1	0.3	
	50	0.8	0.1	1.2	0.1	0.9	0.1	0.74	0.1	0.52	0.1	0.3	
L	1500	6.3	0.1	0.4	0.1	0.3	0.1	0.25	0.1	0.2	0.1	0.12	
	1000	4.2	0.1	0.4	0.1	0.3	0.1	0.25	0.1	0.2	0.1	0.12	
	750	3.1	0.1	0.4	0.1	0.3	0.1	0.25	0.1	0.2	0.1	0.12	
	500	2.1	0.1	0.4	0.1	0.3	0.1	0.25	0.1	0.2	0.1	0.12	
	300	1.3	0.1	0.4	0.1	0.3	0.1	0.25	0.1	0.2	0.1	0.12	
	100	0.4	0.1	0.4	0.1	0.3	0.1	0.25	0.1	0.2	0.1	0.12	
	50	0.2	0.1	0.4	0.1	0.3	0.1	0.25	0.1	0.2	0.1	0.12	

Rapporto / Ratio / Verhältnis		UP5 TR 18x4										5000 N	
		Carico / Load / Last [kN]		5		4		3		2		1	
		nn1 giri/min rpm U/mi	Velocità Speed Geschwindigkeit [mm/s]	Pi [kW]	Mt [Nm]	Pi [kW]	Mt [Nm]	Pi [kW]	Mt [Nm]	Pi [kW]	Mt [Nm]	Pi [kW]	Mt [Nm]
N	1500	25.0	0.42	2.7	0.33	2.1	0.25	1.6	0.17	1.1	0.1	0.6	
	1000	16.7	0.28	2.7	0.22	2.1	0.17	1.6	0.12	1.1	0.1	0.6	
	750	12.5	0.21	2.7	0.16	2.1	0.13	1.6	0.1	1.1	0.1	0.6	
	500	8.3	0.14	2.7	0.11	2.1	0.1	1.6	0.1	1.1	0.1	0.6	
	300	5.0	0.1	2.7	0.1	2.1	0.1	1.6	0.1	1.1	0.1	0.6	
	100	1.7	0.1	2.7	0.1	2.1	0.1	1.6	0.1	1.1	0.1	0.6	
	50	0.8	0.1	2.7	0.1	2.1	0.1	1.6	0.1	1.1	0.1	0.6	
L	1500	6.3	0.14	0.9	0.1	0.7	0.1	0.5	0.1	0.4	0.1	0.3	
	1000	4.2	0.1	0.9	0.1	0.7	0.1	0.5	0.1	0.4	0.1	0.3	
	750	3.1	0.1	0.9	0.1	0.7	0.1	0.5	0.1	0.4	0.1	0.3	
	500	2.1	0.1	0.9	0.1	0.7	0.1	0.5	0.1	0.4	0.1	0.3	
	300	1.3	0.1	0.9	0.1	0.7	0.1	0.5	0.1	0.4	0.1	0.3	
	100	0.4	0.1	0.9	0.1	0.7	0.1	0.5	0.1	0.4	0.1	0.3	
	50	0.2	0.1	0.9	0.1	0.7	0.1	0.5	0.1	0.4	0.1	0.3	

Rapporto / Ratio / Verhältnis		UP10 TR 20x4										10000 N	
		Carico / Load / Last [kN]		10		8		6		4		2	
		nn1 giri/min rpm U/mi	Velocità Speed Geschwindigkeit [mm/s]	Pi [kW]	Mt [Nm]	Pi [kW]	Mt [Nm]	Pi [kW]	Mt [Nm]	Pi [kW]	Mt [Nm]	Pi [kW]	Mt [Nm]
N	1500	25.0	0.88	5.6	0.71	4.5	0.55	3.5	0.38	2.4	0.20	1.3	
	1000	16.7	0.59	5.6	0.47	4.5	0.37	3.5	0.25	2.4	0.14	1.3	
	750	12.5	0.44	5.6	0.35	4.5	0.27	3.5	0.19	2.4	0.1	1.3	
	500	8.3	0.29	5.6	0.24	4.5	0.18	3.5	0.13	2.4	0.1	1.3	
	300	5.0	0.18	5.6	0.14	4.5	0.11	3.5	0.1	2.4	0.1	1.3	
	100	1.7	0.1	5.6	0.1	4.5	0.1	3.5	0.1	2.4	0.1	1.3	
	50	0.8	0.1	5.6	0.1	4.5	0.1	3.5	0.1	2.4	0.1	1.3	
L	1500	6.3	0.25	1.6	0.20	1.3	0.17	1.1	0.13	0.8	0.1	0.4	
	1000	4.2	0.17	1.6	0.14	1.3	0.12	1.1	0.1	0.8	0.1	0.4	
	750	3.1	0.13	1.6	0.1	1.3	0.1	1.1	0.1	0.8	0.1	0.4	
	500	2.1	0.1	1.6	0.1	1.3	0.1	1.1	0.1	0.8	0.1	0.4	
	300	1.3	0.1	1.6	0.1	1.3	0.1	1.1	0.1	0.8	0.1	0.4	
	100	0.4	0.1	1.6	0.1	1.3	0.1	1.1	0.1	0.8	0.1	0.4	
	50	0.2	0.1	1.6	0.1	1.3	0.1	1.1	0.1	0.8	0.1	0.4	

UP - TR

Prestazioni martinetti - TR

Jack performance - TR

Leistung der Hubgetriebe - TR

		UP25 TR 30x6														25000 N	
		Carico / Load / Last [kN]		25		20		15		10		7,5		5		2.5	
		nn1 giri/min rpm U/mi	Velocità Speed Geschwindigkeit [mm/s]	Pi [kW]	Mt [Nm]	Pi [kW]	Mt [Nm]	Pi [kW]	Mt [Nm]	Pi [kW]	Mt [Nm]	Pi [kW]	Mt [Nm]	Pi [kW]	Mt [Nm]	Pi [kW]	Mt [Nm]
Rapporto / Ratio / Verhältnis	N	1500	25.0	2.29	14.6	1.85	11.7	1.40	8.9	0.94	6	0.72	4.6	0.50	3.2	0.28	1.8
		1000	16.7	1.53	14.6	1.23	11.7	0.93	8.9	0.63	6	0.48	4.6	0.34	3.2	0.19	1.8
		750	12.5	1.15	14.6	0.92	11.7	0.70	8.9	0.47	6	0.36	4.6	0.25	3.2	0.14	1.8
		500	8.3	0.77	14.6	0.06	11.7	0.47	8.9	0.31	6	0.24	4.6	0.17	3.2	0.10	1.8
		300	5.0	0.46	14.6	0.37	11.7	0.28	8.9	0.19	6	0.14	4.6	0.1	3.2	0.10	1.8
		100	1.7	0.15	14.6	0.12	11.7	0.1	8.9	0.1	6	0.1	4.6	0.1	3.2	0.10	1.8
		50	0.8	0.1	14.6	0.1	11.7	0.1	8.9	0.1	6	0.1	4.6	0.1	3.2	0.10	1.8
	L	1500	6.3	0.69	4.4	0.57	3.6	0.44	2.8	0.3	1.9	0.24	1.5	0.16	1.0	0.11	0.7
		1000	4.2	0.46	4.4	0.38	3.6	0.29	2.8	0.2	1.9	0.16	1.5	0.10	1.0	0.1	0.7
		750	3.1	0.35	4.4	0.28	3.6	0.22	2.8	0.15	1.9	0.12	1.5	0.1	1.0	0.1	0.7
		500	2.1	0.23	4.4	0.19	3.6	0.15	2.8	0.1	1.9	0.1	1.5	0.1	1.0	0.1	0.7
		300	1.3	0.14	4.4	0.11	3.6	0.1	2.8	0.1	1.9	0.1	1.5	0.1	1.0	0.1	0.7
		100	0.4	0.1	4.4	0.1	3.6	0.1	2.8	0.1	1.9	0.1	1.5	0.1	1.0	0.1	0.7
		50	0.2	0.1	4.4	0.1	3.6	0.1	2.8	0.1	1.9	0.1	1.5	0.1	1.0	0.1	0.7

		UP50 TR 40x7														50000 N	
		Carico / Load / Last [kN]		50		40		30		20		15		10		5	
		nn1 giri/min rpm U/mi	Velocità Speed Geschwindigkeit [mm/s]	Pi [kW]	Mt [Nm]	Pi [kW]	Mt [Nm]	Pi [kW]	Mt [Nm]	Pi [kW]	Mt [Nm]	Pi [kW]	Mt [Nm]	Pi [kW]	Mt [Nm]	Pi [kW]	Mt [Nm]
Rapporto / Ratio / Verhältnis	N	1500	25.0	4.65	29.6	3.74	23.8	2.83	18	1.93	12.3	1.48	9.4	1.02	6.5	0.57	3.6
		1000	16.7	3.10	29.6	2.49	23.8	1.88	18	1.29	12.3	0.98	9.4	0.68	6.5	0.38	3.6
		750	12.5	2.32	29.6	1.87	23.8	1.41	18	0.97	12.3	0.74	9.4	0.51	6.5	0.28	3.6
		500	8.3	1.55	29.6	1.25	23.8	0.94	18	0.64	12.3	0.49	9.4	0.34	6.5	0.19	3.6
		300	5.0	0.93	29.6	0.75	23.8	0.57	18	0.39	12.3	0.3	9.4	0.20	6.5	0.11	3.6
		100	1.7	0.31	29.6	0.25	23.8	0.19	18	0.13	12.3	0.1	9.4	0.1	6.5	0.1	3.6
		50	0.8	0.15	29.6	0.12	23.8	0.1	18	0.1	12.3	0.1	9.4	0.1	6.5	0.1	3.6
	L	1500	6.3	1.40	8.9	1.14	7.2	0.88	5.6	0.61	3.9	0.47	3	0.35	2.2	0.22	1.4
		1000	4.2	0.93	8.9	0.75	7.2	0.59	5.6	0.41	3.9	0.31	3	0.22	2.2	0.14	1.4
		750	3.1	0.70	8.9	0.57	7.2	0.44	5.6	0.31	3.9	0.24	3	0.2	2.2	0.11	1.4
		500	2.1	0.47	8.9	0.38	7.2	0.29	5.6	0.20	3.9	0.16	3	0.12	2.2	0.1	1.4
		300	1.3	0.28	8.9	0.23	7.2	0.18	5.6	0.12	3.9	0.1	3	0.1	2.2	0.1	1.4
		100	0.4	0.1	8.9	0.1	7.2	0.1	5.6	0.1	3.9	0.1	3	0.1	2.2	0.1	1.4
		50	0.2	0.1	8.9	0.1	7.2	0.1	5.6	0.1	3.9	0.1	3	0.1	2.2	0.1	1.4

		UP100 TR 55x9														100000 N	
		Carico / Load / Last [kN]		100		80		60		40		20		10		5	
		nn1 giri/min rpm U/mi	Velocità Speed Geschwindigkeit [mm/s]	Pi [kW]	Mt [Nm]	Pi [kW]	Mt [Nm]	Pi [kW]	Mt [Nm]	Pi [kW]	Mt [Nm]	Pi [kW]	Mt [Nm]	Pi [kW]	Mt [Nm]	Pi [kW]	Mt [Nm]
Rapporto / Ratio / Verhältnis	N	1500	25.0	10.72	68.3	8.62	54.9	6.53	41.6	4.45	28.3	2.36	15	1.30	8.3	0.79	5.0
		1000	16.7	7.14	68.3	5.75	54.9	4.36	41.6	2.96	28.3	1.57	15	0.87	8.3	0.52	5.0
		750	12.5	5.36	68.3	4.3	54.9	3.27	41.6	2.22	28.3	1.18	15	0.65	8.3	0.39	5.0
		500	8.3	3.57	68.3	2.9	54.9	2.18	41.6	1.48	28.3	0.79	15	0.43	8.3	0.26	5.0
		300	5.0	2.14	68.3	1.7	54.9	1.31	41.6	0.90	28.3	0.47	15	0.26	8.3	0.16	5.0
		100	1.7	0.71	68.3	0.57	54.9	0.44	41.6	0.30	28.3	0.16	15	0.1	8.3	0.1	5.0
		50	0.8	0.357	68.3	0.29	54.9	0.22	41.6	0.15	28.3	0.1	15	0.1	8.3	0.1	5.0
	L	1500	6.3	3.3	21.2	2.70	17.2	2.10	13.1	1.41	9	0.79	5.0	0.47	3.0	0.31	2.0
		1000	4.2	2.2	21.2	1.80	17.2	1.37	13.1	0.94	9	0.52	5.0	0.31	3.0	0.21	2.0
		750	3.1	1.6	21.2	1.35	17.2	1.00	13.1	0.71	9	0.39	5.0	0.2	3.0	0.16	2.0
		500	2.1	1.1	21.2	0.90	17.2	0.70	13.1	0.47	9	0.26	5.0	0.16	3.0	0.1	2.0
		300	1.3	0.66	21.2	0.54	17.2	0.41	13.1	0.28	9	0.16	5.0	0.1	3.0	0.1	2.0
		100	0.4	0.22	21.2	0.18	17.2	0.14	13.1	0.1	9	0.1	5.0	0.1	3.0	0.1	2.0
		50	0.2	0.11	21.2	0.1	17.2	0.1	13.1	0.1	9	0.1	5.0	0.1	3.0	0.1	2.0

Solo con fattore di servizio < 10%
Solo carico statico

Duty cycle < 10%
Only static load permissible

Nur mit Betriebsfaktor < 10 %
Nur statische Belastung

Dimensioni martinetti - TR

Screw jack dimensions - TR

Abmessungen der Hubgetriebe - TR

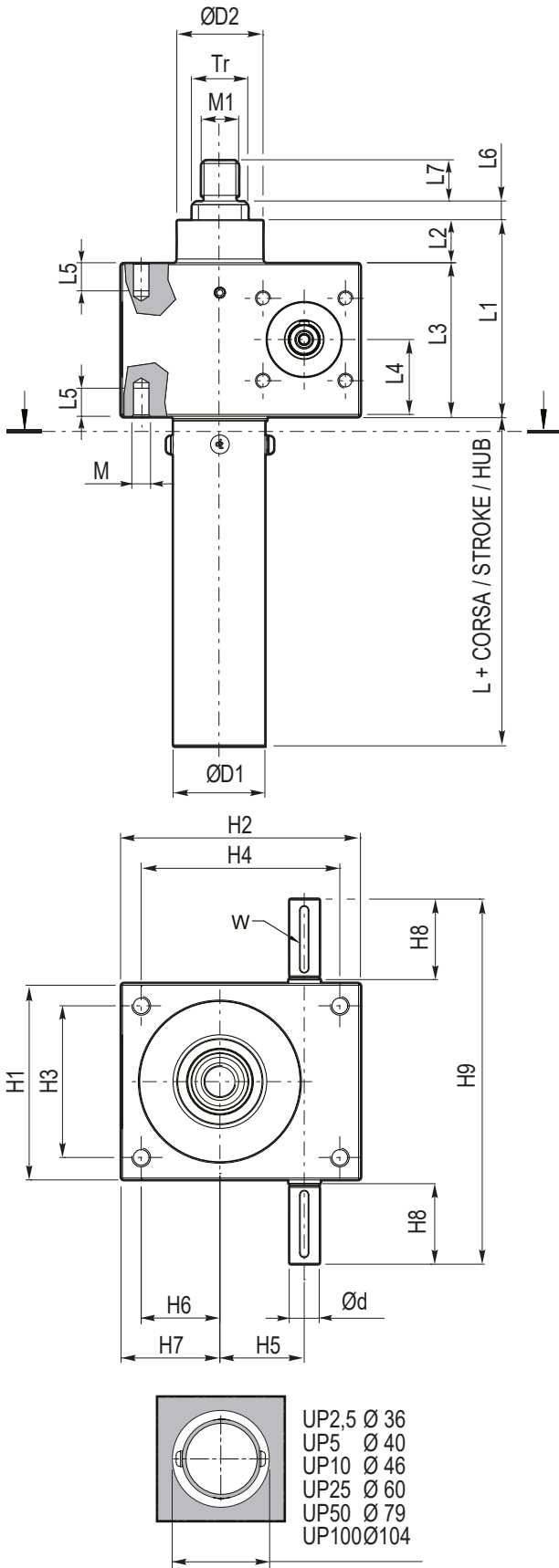

	UP2.5	UP5	UP10	UP25	UP50	UP100
Tr	16X4	18X4	20X4	30X6	40X7	55X9
Ø d	Ø 9	Ø 10	Ø 14	Ø 16	Ø 20	Ø 24
Ø D1	Ø 28	Ø 32	Ø 38	Ø 50	Ø 65	Ø 90
Ø D2	Ø 26	Ø 30	Ø 39	Ø 46	Ø 60	Ø 85
H1	50	72	85	105	145	165
H2	60	78	98	128	180	200
H3	38	52	63	81	115	131
H4	48	60	78	106	150	166
H5	20	25	32	45	63	71
H6	16	21	29	42	63	66
H7	22	30	39	53	78	83
H8	20	22.5	25	43	45	65
H9	92	120	140	195	240	300
L	63	68	71	76	94	115
L1	62	74	93	105	149	200
L2	12	12	18	23	32	40
L3	50	62	75	82	117	160
L4	25	31	37.5	41	58.5	80
L5	12	13	15	15	20	30
L6	10	10	10	10	10	10
L7	12	19	20	22	29	48
M	M6	M8	M8	M10	M12	M20
M1	M8	M12	M14	M20	M30	M36
W	3X3X14	3X3X18	5X5X20	5X5X36	6X6X36	8X7X56

UP - TR

Dimensioni martinetti - TR

Screw jack dimensions - TR

Abmessungen der Hubgetriebe - TR

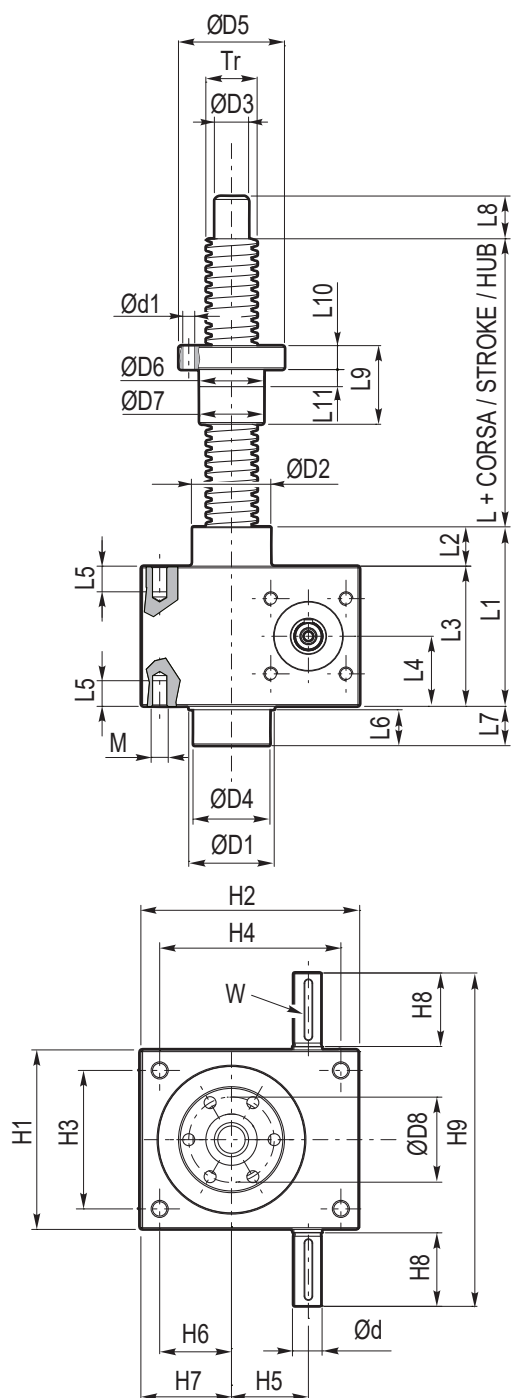

	UP2.5	UP5	UP10	UP25	UP50	UP100
Tr	16X4	18X4	20X4	30X6	40X7	55X9
$\varnothing d$	$\varnothing 9$	$\varnothing 10$	$\varnothing 14$	$\varnothing 16$	$\varnothing 20$	$\varnothing 24$
$\varnothing d1$	$\varnothing 6$	$\varnothing 6$	$\varnothing 7$	$\varnothing 7$	$\varnothing 9$	$\varnothing 11$
$\varnothing D1$	$\varnothing 28$	$\varnothing 32$	$\varnothing 38$	$\varnothing 50$	$\varnothing 60$	$\varnothing 84$
$\varnothing D2$	$\varnothing 26$	$\varnothing 30$	$\varnothing 39$	$\varnothing 46$	$\varnothing 60$	$\varnothing 85$
$\varnothing D3$	$\varnothing 10$	$\varnothing 12$	$\varnothing 15$	$\varnothing 20$	$\varnothing 25$	$\varnothing 40$
$\varnothing D4$	$\varnothing 25$	$\varnothing 28$	$\varnothing 34$	$\varnothing 45$	$\varnothing 60$	$\varnothing 110$
$\varnothing D5$	$\varnothing 48$	$\varnothing 48$	$\varnothing 55$	$\varnothing 62$	$\varnothing 95$	$\varnothing 110$
$\varnothing D6$	$\varnothing 28$	$\varnothing 28$	$\varnothing 32$	$\varnothing 38$	$\varnothing 63$	$\varnothing 72$
$\varnothing D7$	$\varnothing 27.8$	$\varnothing 27.8$	$\varnothing 31.8$	$\varnothing 37.8$	$\varnothing 62.8$	$\varnothing 71.8$
$\varnothing D8$	$\varnothing 38$	$\varnothing 38$	$\varnothing 45$	$\varnothing 50$	$\varnothing 78$	$\varnothing 90$
H1	50	72	85	105	145	165
H2	60	78	98	128	180	200
H3	38	52	63	81	115	131
H4	48	60	78	106	150	166
H5	20	25	32	45	63	71
H6	16	21	29	42	63	66
H7	22	30	39	53	78	83
H8	20	22.5	25	43	45	65
H9	92	120	140	195	240	300
L	64	64	64	66	93	117
L1	62	74	93	105	149	200
L2	12	12	18	23	32	40
L3	50	62	75	82	117	160
L4	25	31	37.5	41	58.5	80
L5	12	13	15	15	20	30
L6	11	14	17	21	32	32
L7	13	16	19	23	32	32
L8	12	15	20	25	30	45
L9	44	44	44	46	73	97
L10	12	12	12	14	16	18
L11	8	8	8	10	12	30
M	M6	M8	M8	M10	M12	M20
W	3X3X14	3X3X18	5X5X20	5X5X36	6X6X36	8X7X56
Tr	16X4	18X4	20X4	30X6	40X7	55X9

**Martinetti UP con vite
a ricircolo di sfere - VRS**

**UP ball screw
jacks - VRS**

**UP-Hubgetriebe mit
Kugelumlaufspindel - VRS**



Versione / Versione / Ausführung VRS								
Tipo / Type / Typ		UP2.5	UP5	UP10	UP25	UP50	UP100	
Carico statico max in trazione / compressione <i>Max pull / compression static load</i> Maximale statische Zug-/Druckbelastung		[kN]	2.5	5	10	25	50	100
Carico dinamico max. in trazione / compressione <i>Max pull / compression dynamic load</i> Max dynamische Zug-/ Druckbelastung		[kN]	Vedi tabelle prestazioni e tabella coefficienti di carico delle chiocciole VRS <i>See performance tables and admitted loads on ball screw nuts</i> Siehe Leistungstabelle und Lastkoeffiziententabelle der VRS-Muttern					
Vite VRS <i>Ball screw</i> VRS Spindel			16x5	16x5	20x5	32x10	40x10	50x10
Ca	Capacità di carico dinamico <i>Admitted dynamic load</i> Dynamische Lastkapazität	[daN]	1160	1160	1525	5254	6611	7050
Co	Capacità di carico statico <i>Admitted static load</i> Statische Lastkapazität	[daN]	1191	1191	1985	5876	9377	12714
Rapporto Normale N Normal ratio N Normales Untersetzungsverhältnis N	Rapporto di riduzione normale <i>Normal ratio</i> Normales Untersetzungsverhältnis		1:4	1:4	1:4	1:6	1:7	1:9
	Corsa vite per giro albero ingresso <i>Lead screw stroke per revolution input turn</i> Spindelhub pro Drehung an der Eingangswelle	[mm]	1.25	1.25	1.25	1.66	1.42	1.1
	Rendimento totale del martinetto con rapporto normale <i>Total screw jack efficiency for normal ratio</i> Gesamtwirkungsgrad des Spindelhubgetriebes mit normalem Untersetzungsverhältnis		0.82	0.83	0.81	0.84	0.82	0.82
	Coppia a vuoto * <i>Idling torque *</i> Leerlaufmoment *	[Nm]	0.08	0.12	0.26	0.36	0.76	1.68
	Coppia max. ammessa sul singolo martinetto ** <i>Max. permissible torque on the single jack **</i> Maximal zulässiges Drehmoment am einzelnen Spindelhubgetriebe **	[Nm]	1.6	5.0	13.0	20.0	45.0	60.0
Rapporto lento L Slow ratio L Langsames Untersetzungsverhältnis L	Rapporto lento <i>Slow ratio</i> Langsames Untersetzungsverhältnis		1:16	1:16	1:16	1:24	1:28	1:36
	Corsa vite per giro albero ingresso <i>Lead screw stroke per revolution input turn</i> Spindelhub pro Drehung an der Eingangswelle	[mm]	0.31	0.31	0.31	0.41	0.37	0.27
	Rendimento totale del martinetto con rapporto lento <i>Total screw jack efficiency for slow ratio</i> Gesamtwirkungsgrad des Spindelhubgetriebes mit langsamem Untersetzungsverhältnis		0.73	0.70	0.74	0.72	0.71	0.68
	Coppia a vuoto * <i>Idling torque *</i> Leerlaufmoment *	[Nm]	0.08	0.12	0.26	0.36	0.76	1.68
	Coppia max. ammessa sul singolo martinetto ** <i>Max. permissible torque on the single jack **</i> Maximal zulässiges Drehmoment am einzelnen Spindelhubgetriebe **	[Nm]	0.5	1.6	3.0	8.0	15.0	19.0
Coppia max. ammissibile sulla vite senza fine <i>Max permissible torque at worm shaft</i> Maximal zulässiges Drehmoment an der Spindel		[Nm]	10	16	38	63	130	265

* Il valore riportato in tabella è da considerarsi dopo la fase di rodaggio.

** Il valore è riferito alla coppia massima ammessa sulla vite per sistemi a più martinetti.

* *The value shown in the table is to be considered after the running-in phase.*

** *The value refers to the maximum allowed torque on the screw for multiple-jack systems.*

* Der in der Tabelle angegeben Wert gilt nach der Einlaufphase.

** Der Wert bezieht sich auf das maximal zulässige Drehmoment an der Spindel für Systeme mit mehreren Spindelhubgetrieben.

Prestazioni martinetti - VRS

Jack performance - VRS

Leistung der Hubgetriebe - VRS

		UP2.5 VRS 16x5										2500 N	
		Carico/Load/Last [kN]		2.5		2		1.5		1		0.5	
		nn1 giri/min rpm U/mi	Velocità Speed Geschwindigkeit [mm/s]	Pi [kW]	Mt [Nm]	Pi [kW]	Mt [Nm]	Pi [kW]	Mt [Nm]	Pi [kW]	Mt [Nm]	Pi [kW]	Mt [Nm]
Rapporto / Ratio / Verhältnis	N	1500	31.3	0.1	0.7	0.1	0.6	0.1	0.5	0.1	0.3	0.1	0.2
		1000	20.8	0.1	0.7	0.1	0.6	0.1	0.5	0.1	0.3	0.1	0.2
		750	15.6	0.1	0.7	0.1	0.6	0.1	0.5	0.1	0.3	0.1	0.2
		500	10.4	0.1	0.7	0.1	0.6	0.1	0.5	0.1	0.3	0.1	0.2
		300	6.3	0.1	0.7	0.1	0.6	0.1	0.5	0.1	0.3	0.1	0.2
		100	2.1	0.1	0.7	0.1	0.6	0.1	0.5	0.1	0.3	0.1	0.2
		50	1.0	0.1	0.7	0.1	0.6	0.1	0.5	0.1	0.3	0.1	0.2
	L	1500	7.8	0.1	0.3	0.1	0.2	0.1	0.16	0.1	0.13	0.1	0.1
		1000	5.2	0.1	0.3	0.1	0.2	0.1	0.16	0.1	0.13	0.1	0.1
		750	3.9	0.1	0.3	0.1	0.2	0.1	0.16	0.1	0.13	0.1	0.1
		500	2.6	0.1	0.3	0.1	0.2	0.1	0.16	0.1	0.13	0.1	0.1
		300	1.6	0.1	0.3	0.1	0.2	0.1	0.16	0.1	0.13	0.1	0.1
		100	0.5	0.1	0.3	0.1	0.2	0.1	0.16	0.1	0.13	0.1	0.1
		50	0.3	0.1	0.3	0.1	0.2	0.1	0.16	0.1	0.13	0.1	0.1

		UP5 VRS 16x5										5000 N	
		Carico/Load/Last [kN]		5		4		3		2		1	
		nn1 giri/min rpm U/mi	Velocità Speed Geschwindigkeit [mm/s]	Pi [kW]	Mt [Nm]	Pi [kW]	Mt [Nm]	Pi [kW]	Mt [Nm]	Pi [kW]	Mt [Nm]	Pi [kW]	Mt [Nm]
Rapporto / Ratio / Verhältnis	N	1500	31.3	0.20	1.3	0.16	1	0.13	0.8	0.1	0.6	0.1	0.4
		1000	20.8	0.14	1.3	0.1	1	0.1	0.8	0.1	0.6	0.1	0.4
		750	15.6	0.1	1.3	0.1	1	0.1	0.8	0.1	0.6	0.1	0.4
		500	10.4	0.1	1.3	0.1	1	0.1	0.8	0.1	0.6	0.1	0.4
		300	6.3	0.1	1.3	0.1	1	0.1	0.8	0.1	0.6	0.1	0.4
		100	2.1	0.1	1.3	0.1	1	0.1	0.8	0.1	0.6	0.1	0.4
		50	1.0	0.1	1.3	0.1	1	0.1	0.8	0.1	0.6	0.1	0.4
	L	1500	7.8	0.1	0.5	0.1	0.4	0.1	0.3	0.1	0.3	0.1	0.2
		1000	5.2	0.1	0.5	0.1	0.4	0.1	0.3	0.1	0.3	0.1	0.2
		750	3.9	0.1	0.5	0.1	0.4	0.1	0.3	0.1	0.3	0.1	0.2
		500	2.6	0.1	0.5	0.1	0.4	0.1	0.3	0.1	0.3	0.1	0.2
		300	1.6	0.1	0.5	0.1	0.4	0.1	0.3	0.1	0.3	0.1	0.2
		100	0.5	0.1	0.5	0.1	0.4	0.1	0.3	0.1	0.3	0.1	0.2
		50	0.3	0.1	0.5	0.1	0.4	0.1	0.3	0.1	0.3	0.1	0.2

		UP10 VRS 20x5										10000 N	
		Carico/Load/Last [kN]		10		8		6		4		2	
		nn1 giri/min rpm U/mi	Velocità Speed Geschwindigkeit [mm/s]	Pi [kW]	Mt [Nm]	Pi [kW]	Mt [Nm]	Pi [kW]	Mt [Nm]	Pi [kW]	Mt [Nm]	Pi [kW]	Mt [Nm]
Rapporto / Ratio / Verhältnis	N	1500	31.3	0.42	2.7	0.35	2.2	0.27	1.7	0.19	1.2	0.13	0.8
		1000	20.8	0.28	2.7	0.22	2.2	0.18	1.7	0.13	1.2	0.1	0.8
		750	15.6	0.21	2.7	0.17	2.2	0.13	1.7	0.1	1.2	0.1	0.8
		500	10.4	0.14	2.7	0.12	2.2	0.1	1.7	0.1	1.2	0.1	0.8
		300	6.3	0.1	2.7	0.1	2.2	0.1	1.7	0.1	1.2	0.1	0.8
		100	2.1	0.1	2.7	0.1	2.2	0.1	1.7	0.1	1.2	0.1	0.8
		50	1.0	0.1	2.7	0.1	2.2	0.1	1.7	0.1	1.2	0.1	0.8
	L	1500	7.8	0.11	0.7	0.1	0.6	0.1	0.5	0.1	0.4	0.1	0.3
		1000	5.2	0.1	0.7	0.1	0.6	0.1	0.5	0.1	0.4	0.1	0.3
		750	3.9	0.1	0.7	0.1	0.6	0.1	0.5	0.1	0.4	0.1	0.3
		500	2.6	0.1	0.7	0.1	0.6	0.1	0.5	0.1	0.4	0.1	0.3
		300	1.6	0.1	0.7	0.1	0.6	0.1	0.5	0.1	0.4	0.1	0.3
		100	0.5	0.1	0.7	0.1	0.6	0.1	0.5	0.1	0.4	0.1	0.3
		50	0.3	0.1	0.7	0.1	0.6	0.1	0.5	0.1	0.4	0.1	0.3

UP - VRS

Prestazioni martinetti -VRS

Jack performance - VRS

Leistung der Hubgetriebe -VRS

		UP25 VRS 32x10														25000 N	
		Carico / Load / Last [kN]		25		20		15		10		7,5		5		2.5	
		nn1 giri/min rpm U/mi	Velocità Speed Geschwindigkeit [mm/s]	Pi [kW]	Mt [Nm]	Pi [kW]	Mt [Nm]	Pi [kW]	Mt [Nm]	Pi [kW]	Mt [Nm]	Pi [kW]	Mt [Nm]	Pi [kW]	Mt [Nm]	Pi [kW]	Mt [Nm]
Rapporto / Ratio / Verhältnis	N	1500	41.6	1.30	8.3	1.05	6.7	0.80	5.1	0.55	3.5	0.44	2.8	0.31	2.0	0.19	1.2
		1000	27.8	0.87	8.3	0.70	6.7	0.53	5.1	0.37	3.5	0.29	2.8	0.21	2.0	0.13	1.2
		750	20.8	0.65	8.3	0.53	6.7	0.40	5.1	0.27	3.5	0.22	2.8	0.16	2.0	0.1	1.2
		500	13.9	0.43	8.3	0.35	6.7	0.27	5.1	0.18	3.5	0.15	2.8	0.1	2.0	0.1	1.2
		300	8.3	0.26	8.3	0.21	6.7	0.16	5.1	0.11	3.5	0.1	2.8	0.1	2.0	0.1	1.2
		100	2.8	0.1	8.3	0.1	6.7	0.1	5.1	0.1	3.5	0.1	2.8	0.1	2.0	0.1	1.2
		50	1.4	0.1	8.3	0.1	6.7	0.1	5.1	0.1	3.5	0.1	2.8	0.1	2.0	0.1	1.2
	L	1500	41.6	1.30	8.3	1.05	6.7	0.80	5.1	0.55	3.5	0.44	2.8	0.31	2.0	0.19	1.2
		1000	27.8	0.87	8.3	0.70	6.7	0.53	5.1	0.37	3.5	0.29	2.8	0.21	2.0	0.13	1.2
		750	20.8	0.65	8.3	0.53	6.7	0.40	5.1	0.27	3.5	0.22	2.8	0.16	2.0	0.1	1.2
		500	13.9	0.43	8.3	0.35	6.7	0.27	5.1	0.18	3.5	0.15	2.8	0.1	2.0	0.1	1.2
		300	8.3	0.26	8.3	0.21	6.7	0.16	5.1	0.11	3.5	0.1	2.8	0.1	2.0	0.1	1.2
		100	2.8	0.1	8.3	0.1	6.7	0.1	5.1	0.1	3.5	0.1	2.8	0.1	2.0	0.1	1.2
		50	1.4	0.1	8.3	0.1	6.7	0.1	5.1	0.1	3.5	0.1	2.8	0.1	2.0	0.1	1.2

		UP50 VRS 40x10														50000 N	
		Carico / Load / Last [kN]		50		40		30		20		15		10		5	
		nn1 giri/min rpm U/mi	Velocità Speed Geschwindigkeit [mm/s]	Pi [kW]	Mt [Nm]	Pi [kW]	Mt [Nm]	Pi [kW]	Mt [Nm]	Pi [kW]	Mt [Nm]	Pi [kW]	Mt [Nm]	Pi [kW]	Mt [Nm]	Pi [kW]	Mt [Nm]
Rapporto / Ratio / Verhältnis	N	1500	35.7	2.28	14.5	1.85	11.8	1.41	9	0.99	6.3	0.77	4.9	0.55	3.5	0.33	2.1
		1000	23.8	1.52	14.5	1.24	11.8	0.94	9	0.66	6.3	0.51	4.9	0.37	3.5	0.22	2.1
		750	17.9	1.14	14.5	0.93	11.8	0.71	9	0.49	6.3	0.38	4.9	0.27	3.5	0.16	2.1
		500	11.9	0.76	14.5	0.62	11.8	0.47	9	0.33	6.3	0.26	4.9	0.18	3.5	0.11	2.1
		300	7.1	0.46	14.5	0.37	11.8	0.28	9	0.20	6.3	0.15	4.9	0.11	3.5	0.1	2.1
		100	2.4	0.15	14.5	0.12	11.8	0.1	9	0.1	6.3	0.1	4.9	0.1	3.5	0.1	2.1
		50	1.2	0.1	14.5	0.1	11.8	0.1	9	0.1	6.3	0.1	4.9	0.1	3.5	0.1	2.1
	L	1500	8.9	0.71	4.5	0.60	3.8	0.47	3	0.35	2.2	0.27	1.7	0.20	1.3	0.16	1
		1000	6.0	0.47	4.5	0.40	3.8	0.31	3	0.22	2.2	0.18	1.7	0.14	1.3	0.1	1
		750	4.5	0.35	4.5	0.30	3.8	0.24	3	0.17	2.2	0.13	1.7	0.1	1.3	0.1	1
		500	3.0	0.24	4.5	0.20	3.8	0.16	3	0.12	2.2	0.1	1.7	0.1	1.3	0.1	1
		300	1.8	0.14	4.5	0.12	3.8	0.1	3	0.1	2.2	0.1	1.7	0.1	1.3	0.1	1
		100	0.6	0.1	4.5	0.1	3.8	0.1	3	0.1	2.2	0.1	1.7	0.1	1.3	0.1	1
		50	0.3	0.1	4.5	0.1	3.8	0.1	3	0.1	2.2	0.1	1.7	0.1	1.3	0.1	1

		UP100 VRS 50x10														100000 N	
		Carico / Load / Last [kN]		100		80		60		40		20		10		5	
		nn1 giri/min rpm U/mi	Velocità Speed Geschwindigkeit [mm/s]	Pi [kW]	Mt [Nm]	Pi [kW]	Mt [Nm]	Pi [kW]	Mt [Nm]	Pi [kW]	Mt [Nm]	Pi [kW]	Mt [Nm]	Pi [kW]	Mt [Nm]	Pi [kW]	Mt [Nm]
Rapporto / Ratio / Verhältnis	N	1500	27.8	3.62	23	2.95	18.8	2.28	14.5	1.6	10.2	0.94	6	0.60	3.8	0.42	2.7
		1000	18.5	2.41	23	1.97	18.8	1.52	14.5	1.1	10.2	0.63	6	0.40	3.8	0.28	2.7
		750	13.9	1.81	23	1.47	18.8	1.14	14.5	0.8	10.2	0.47	6	0.30	3.8	0.21	2.7
		500	9.2	1.21	23	0.98	18.8	0.76	14.5	0.53	10.2	0.31	6	0.20	3.8	0.14	2.7
		300	5.5	0.72	23	0.59	18.8	0.46	14.5	0.32	10.2	0.19	6	0.12	3.8	0.1	2.7
		100	1.8	0.24	23	0.2	18.8	0.15	14.5	0.11	10.2	0.1	6	0.1	3.8	0.1	2.7
		50	0.9	0.12	23	0.1	18.8	0.1	14.5	0.1	10.2	0.1	6	0.1	3.8	0.1	2.7
	L	1500	6.9	1.18	7.5	0.97	6.2	0.77	4.9	0.57	3.6	0.36	2.3	0.27	1.7	0.20	1.3
		1000	4.6	0.79	7.5	0.65	6.2	0.51	4.9	0.38	3.6	0.24	2.3	0.18	1.7	0.14	1.3
		750	3.4	0.59	7.5	0.49	6.2	0.38	4.9	0.28	3.6	0.18	2.3	0.13	1.7	0.1	1.3
		500	2.3	0.39	7.5	0.32	6.2	0.26	4.9	0.19	3.6	0.12	2.3	0.1	1.7	0.1	1.3
		300	1.3	0.24	7.5	0.19	6.2	0.15	4.9	0.11	3.6	0.1	2.3	0.1	1.7	0.1	1.3
		100	0.5	0.1	7.5	0.1	6.2	0.1	4.9	0.1	3.6	0.1	2.3	0.1	1.7	0.1	1.3
		50	0.2	0.1	7.5	0.1	6.2	0.1	4.9	0.1	3.6	0.1	2.3	0.1	1.7	0.1	1.3

ATTENZIONE!: I valori riportati nelle tabelle prestazionali delle versioni con vite a ricircolo di sfere riportano la potenza e il momento torcente in entrata in funzione al carico da movimentare. I limiti di carico dinamico per le varie tipologie di chiocciolate standard sono riportati nella tabella di pag. B30-B31. A richiesta possono essere utilizzate chiocciolate con coefficienti di carico maggiori, per ulteriori informazioni contattare il nostro servizio tecnico-commerciale.

WARNING!: The values shown in the performance tables of versions with recirculating ball screws show input power and torque in relation to the load to be moved. The dynamic load limits for the various types of standard nuts are shown in the table on page B30-B31. On request, nuts with higher load ratings can be used. For further information, contact our technical-sales service.

ACHTUNG!: Die in den Leistungstabellen der Ausführungen mit Kugelumlaufspindel angegebenen Werte beziehen sich auf die Leistung und das Eingangsrehmoment in Abhängigkeit von der zu bewegenden Last. Die dynamischen Belastungsgrenzen für die unterschiedlichen Standard-Laufmuttertypen sind in der Tabelle auf Seite B30-B31 aufgeführt. Auf Wunsch können auch Laufmutter mit höheren Lastkoeffizienten verwendet werden. Weitere Informationen erhalten Sie bei unserem vertriebstechnischen Kundendienst.

Dimensioni martinetti - VRS

Screw jack dimensions - VRS

Abmessungen der Hubgetriebe - VRS

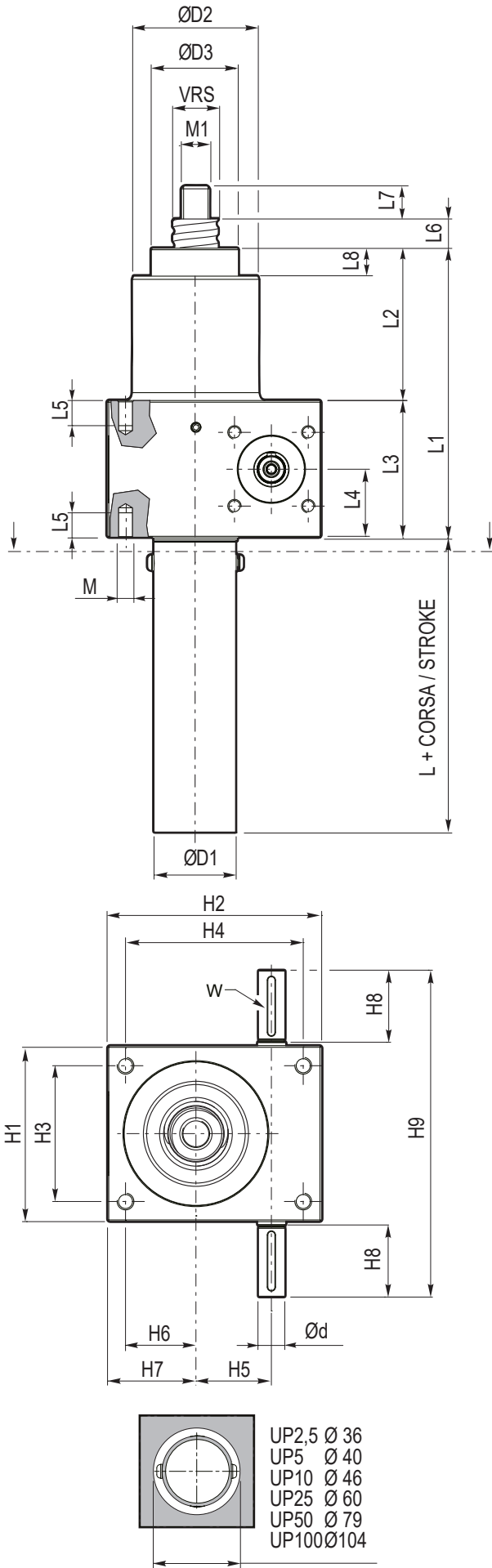

	UP25	UP50	UP100
VRS	32X10	40X10	50X10
Ø d	Ø 16	Ø 20	Ø 24
Ø D1	Ø 50	Ø 65	Ø 90
Ø D2	Ø 65	Ø 85	Ø 95
Ø D3	Ø 85	Ø 115	Ø 130
H1	105	145	165
H2	128	180	200
H3	81	115	131
H4	106	150	166
H5	45	63	71
H6	42	63	66
H7	53	78	83
H8	43	45	65
H9	195	240	300
L	95	108	132
L1	182	217	260
L2	100	100	100
L3	82	117	160
L4	41	58.5	80
L5	15	20	30
L6	20	20	20
L7	22	29	48
L8	15	15	15
M	M10	M12	M20
M1	M20	M30	M36
W	5X5X36	6X6X36	8X7X56

Carichi massimi ammessi per le chiocchie VRS Standard
Max admitted loads on ball screw standard nuts
Maximal zulässige Lasten für Standard-VRS-Laufmuttern

Tipo / Type / Typ	Co [daN]	Ca [daN]
VRS 32X10	5876	5254
VRS 40X10	9377	6611
VRS 50X10	12714	7050

UP - VRS

Dimensioni martinetti - VRS

Screw jack dimensions - VRS

Abmessungen der Hubgetriebe - VRS

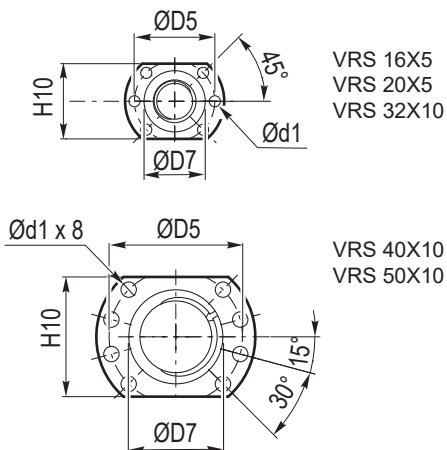
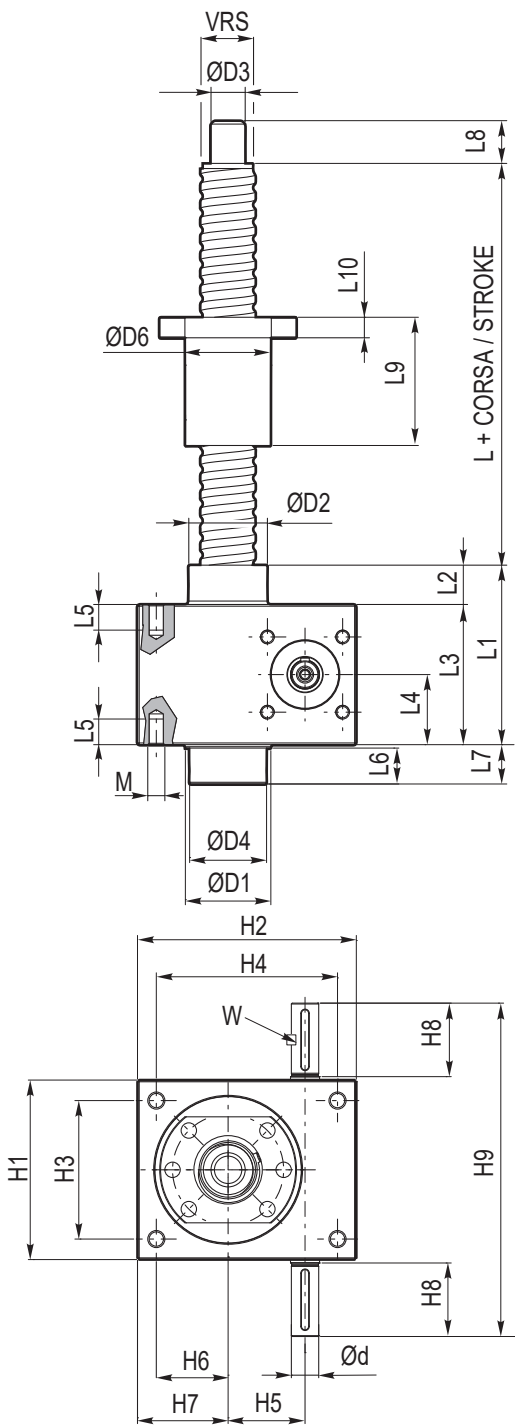

VRS 16X5
VRS 20X5
VRS 32X10

VRS 40X10
VRS 50X10

	UP2.5	UP5	UP10	UP25	UP50	UP100
VRS	16X5	16X5	20X5	32X10	40X10	50X10
Ø d	Ø 9	Ø 10	Ø 14	Ø 16	Ø 20	Ø 24
Ø d1	Ø 5.5	Ø 5.5	Ø 6.6	Ø 9	Ø 9	Ø 11
Ø D1	Ø 28	Ø 32	Ø 38	Ø 50	Ø 60	Ø 84
Ø D2	Ø 26	Ø 30	Ø 39	Ø 46	Ø 60	Ø 85
Ø D3	Ø 10	Ø 12	Ø 15	Ø 20	Ø 25	Ø 40
Ø D4	Ø 25	Ø 28	Ø 34	Ø 45	Ø 60	Ø 110
Ø D5	Ø 48	Ø 48	Ø 58	Ø 80	Ø 93	Ø 110
Ø D6	Ø 28	Ø 28	Ø 36	Ø 50	Ø 63	Ø 75
Ø D7	Ø 38	Ø 38	Ø 47	Ø 65	Ø 78	Ø 93
H1	50	72	85	105	145	165
H2	60	78	98	128	180	200
H3	38	52	63	81	115	131
H4	48	60	78	106	150	166
H5	20	25	32	45	63	71
H6	16	21	29	42	63	66
H7	22	30	39	53	78	83
H8	20	22.5	25	43	45	65
H9	92	120	140	195	240	300
H10	40	40	44	62	70	85
L	80	80	85	115	130	140
L1	62	74	93	105	149	200
L2	12	12	18	23	32	40
L3	50	62	75	82	117	160
L4	25	31	37.5	41	58.5	80
L5	12	13	15	15	20	30
L6	11	14	17	21	32	32
L7	13	16	19	23	32	32
L8	12	15	20	25	30	45
L9	45	45	51	85	88	88
L10	10	10	10	12	14	16
M	M6	M8	M8	M10	M12	M20
W	3X3X14	3X3X18	5X5X20	5X5X36	6X6X36	8X7X56

Carichi massimi ammessi per le chiocciole VRS Standard
Max admitted loads on ball screw standard nuts
Maximal zulässige Lasten für Standard-VRS-Laufmuttern

Tipo / Type / Typ	Co [daN]	Ca [daN]
VRS 16X5	3052	1380
VRS 20X5	3875	1551
VRS 32X10	12208	4805
VRS 40X10	15500	5399
VRS 50X10	19614	6004



Accessori
Accessories
Zubehör

Indice	Index	Index	
Accessori UP - martinetti TR	<i>UP accessories - TR screw jacks</i>	UP-Zubehör - TR-Hubgetriebe	C4
Accessori UP - martinetti VRS	<i>UP accessories - VRS screw jacks</i>	UP-Zubehör - VRS-Hubgetriebe	C5

Questa sezione annulla e sostituisce ogni precedente edizione o revisione. Qualora questa sezione non Vi sia giunta in distribuzione controllata, l'aggiornamento dei dati ivi contenuto non è assicurato. **In tal caso la versione più aggiornata è disponibile sul nostro sito internet www.transtecno.com**

*This section replaces any previous edition and revision. If you obtained this catalogue other than through controlled distribution channels, the most up to date content is not guaranteed. **In this case the latest version is available on our web site www.transtecno.com***

Accessori

Accessories

Zubehör

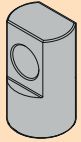
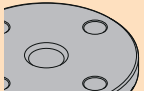
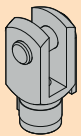
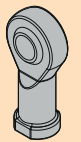
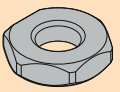
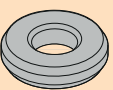
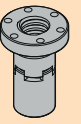
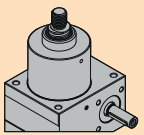
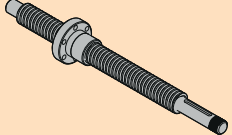
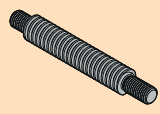
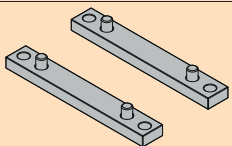

Accessori Accessories Zubehör		Descrizione Description Beschreibung	Utilizzabile sul modello Can be used on model Verwendbar bei Modell				Pagina Page Seite
			UP	Traslante Travelling Stehend	UP	Rotante Rotating Rotierend	
	PE	Terminale oscillante <i>Pivot bearing end</i> <i>Schwenklagerkopf</i>	●			-	C6
	FF	Piattello di fissaggio <i>Fixing Flanged</i> <i>Befestigungsflansch</i>	●			-	C6
	FE	Forcella <i>Forked end</i> <i>Gabelkopf</i>	●			-	C7
	RE	Testa a snodo <i>Rod end</i> <i>Kugelgelenkkopf</i>	●			-	C7
	AD	Antirotazione <i>Antirotation Device</i> <i>Verdrehsicherung</i>	●			-	C8
	EP	Protezione antisfilamento <i>Escape protection</i> <i>Ausdrehsicherung</i>	●			-	C8
	SN-R	Chiocciola di sicurezza <i>Safety Nuts</i> <i>Sicherheitsfangmutter</i>	-			●	C9
	SN-T	Chiocciola di sicurezza <i>Safety Nuts</i> <i>Sicherheitsfangmutter</i>	●			-	C9
	IS	Stelo maggiorato <i>Increased size screw</i> <i>Verlängerte Gewindespindel</i>	-			●	C10
	SSV	Versione inox <i>Stainless steel version</i> <i>Edelstahlausführung</i>	●			●	*
	FS	listelli di fissaggio <i>Fastening strips</i> <i>Befestigungsleisten</i>	●			●	C11

* stesse misure dello standard / same measurements as standard / gleiche Abmessungen wie Standard

Accessori

Accessories

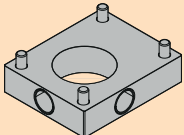
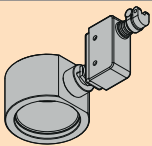
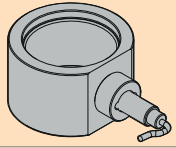
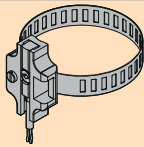
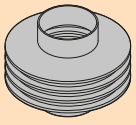
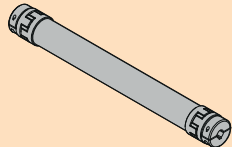
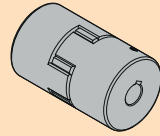
Zubehör

Accessori Accessories Zubehör		Descrizione Description Beschreibung	Utilizzabile sul modello Can be used on model Verwendbar bei Modell				Pagina Page Seite
			UP	Traslante Travelling Stehend	UP	Rotante Rotating Rotierend	
	PBP	Piastre supporto oscillante Pivot bearing plate Schwenklagerplatte	●		●		C11
	MS	Fine corsa meccanici Mechanical limit switches Mechanische Endschalter	●		-		C12
	PLS	Fine corsa induttivi Proximity (Inductive) sensors Induktive Endschalter	●		-		C13
	MLS	Fine corsa magnetici Magnetic limit switches Magnetische Endschalter	●		-		C14
	B	Soffietto Bellows Faltenbalg	●		●		C16
	TS	Albero di trasmissione Transmission shafts Verbindungswelle	●		●		C17
	GR	Giunto Cuplung Kupplung	●		●		C19
	VS	Guarnizioni in viton Viton seals Viton-Dichtungen	●		●		*
	SS	Guarnizioni in silicone Silicone seals Silikon-Dichtungen	●		●		*

Acc./Zub.

* stesse misure dello standard / same measurements as standard / gleiche Abmessungen wie Standard

Accessori UP
martinetti traslanti - TR

UP Accessories
travelling screw jacks - TR

Zubehör UP
Stehende Spindelhubgetriebe - TR

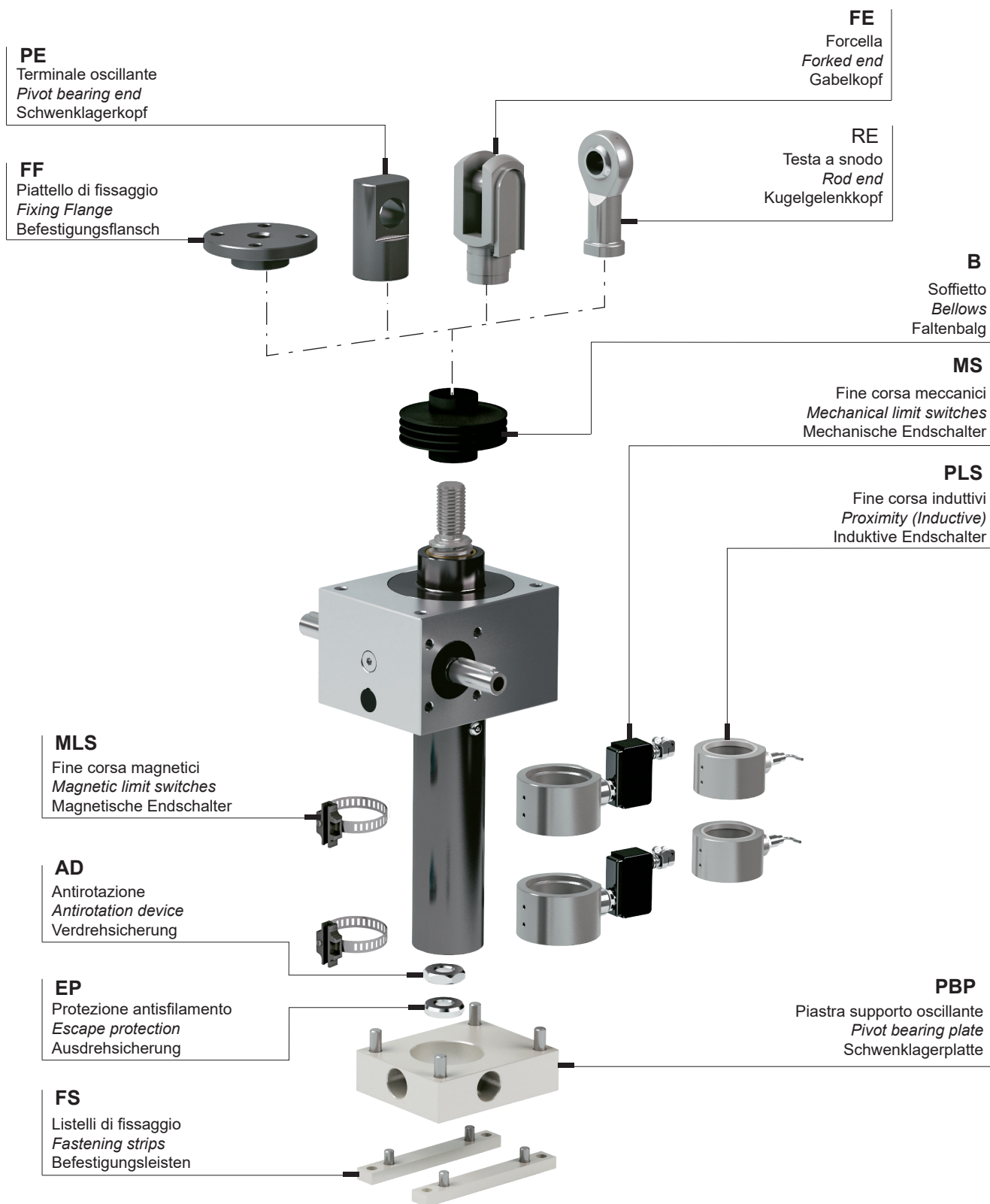

Accessori UP
martinetti rotanti - VRS

UP Accessories
VRS - rotating screw jacks

Zubehör UP
Rotierende Spindelhubgetriebe - VRS

Chiocciola standard
Standard nuts
Standard – Laufmutter

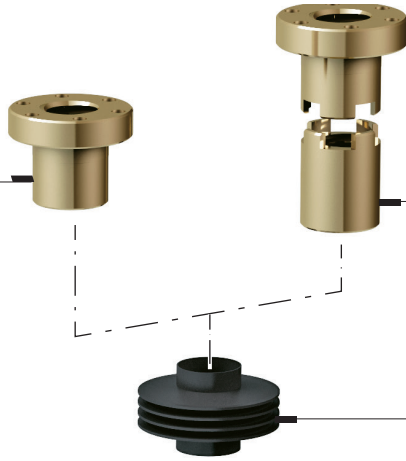

SN
Chiocciola di sicurezza
Sefty nuts
Sicherheitsfangmutter

B
Soffietto
Bellows
Faltenbalg

PBP
Piastra supporto oscillante
Pivot bearing plate
Schwenklagerplatte

FS
Listelli di fissaggio
Fastening strips
Befestigungsleisten

Acc./Zub.

PE
terminale oscillante

PE
pivot bearing end

PE
Schwenklagerkopf

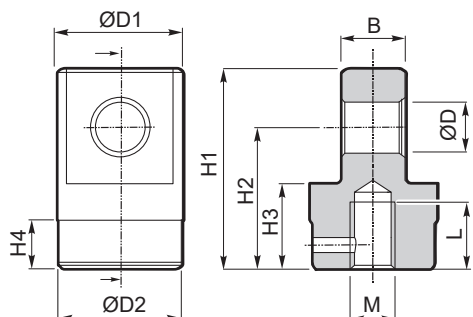

Taglia Size Größe	D1	D2	D H8	H1	H2	H3	H4	B h10	MxL	Kg
UP2.5	Ø 30	Ø 26	Ø 14	51	36	21	15	15	M8x16	0.17
UP5	Ø 30	Ø 30	Ø 14	55	40	25	-	15	M12x20	0.20
UP10	Ø 40	Ø 39	Ø 16	63	45	27	15	20	M14x21	0.42
UP25	Ø 45	Ø 45	Ø 24	78	53	33	-	30	M20x23	0.68
UP50	Ø 60	Ø 60	Ø 32	105	70	40	-	35	M30x30	1.49
UP100	Ø 75	Ø 85	Ø 35	110	75	35	15	45	M36x50	2.51

Materiale: acciaio, con trattamento anticorrosione. (INOX su richiesta)
Material: steel, with anti-corrosion treatment. (Stainless Steel on request)
Material: Stahl mit Korrosionsschutzbehandlung (auf Wunsch INOX-Edelstahl)

FF
piattello di fissaggio

FF
fixing flange

FF
Befestigungsflansch

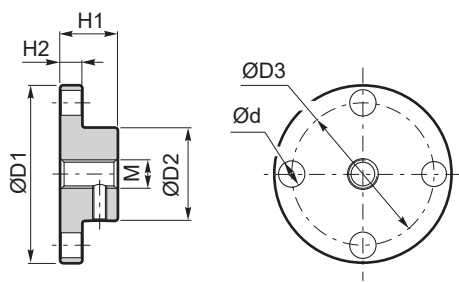

Taglia Size Größe	D1	D2	D3	d	H1	H2	M	Kg
UP2.5	Ø 50	Ø 26	Ø 40	Ø 7	16	6	M8	0.12
UP5	Ø 65	Ø 30	Ø 48	Ø 9	20	7	M12	0.22
UP10	Ø 80	Ø 39	Ø 60	Ø 11	21	8	M14	0.39
UP25	Ø 90	Ø 46	Ø 67	Ø 11	23	10	M20	0.58
UP50	Ø 110	Ø 60	Ø 85	Ø 13	30	15	M30	1.24
UP100	Ø 150	Ø 85	Ø 117	Ø 17	50	20	M36	3.62

Materiale: acciaio, con trattamento anticorrosione. (INOX su richiesta)
Material: steel, with anti-corrosion treatment. (Stainless Steel on request)
Material: Stahl mit Korrosionsschutzbehandlung (auf Wunsch INOX-Edelstahl)

FE
Forcella

FE
fork end

FE
Gabelkopf

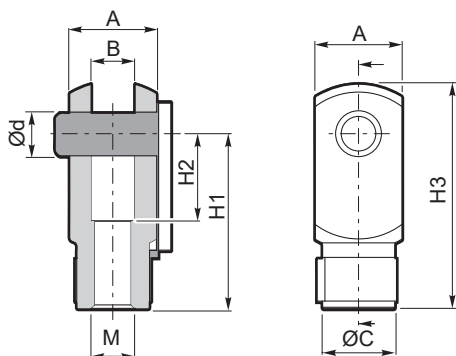

Taglia Size Größe	A	B	C	H1	H2	H3	d	M	Kg
UP2.5	16	8	Ø 14	32	16	42	Ø 8	M8	0.10
UP5	24	12	Ø 20	48	24	62	Ø 12	M12	0.16
UP10	27	14	Ø 24	56	28	72	Ø 14	M14	0.23
UP25	40	20	Ø 34	80	40	105	Ø 20	M20	0.72
UP50	60	30	Ø 52	120	60	160	Ø 30	M30	2.47
UP100	70	35	Ø 60	144	72	188	Ø 35	M36	3.85

Dalla grandezza 2.5 alla 25 le forcelle sono complete di perno con clips.
Nelle grandezze 50 e 100 le forcelle sono complete di perno e seeger
Materiale: acciaio zincato. (INOX su richiesta)

*From sizes 2.5 to 25 fork ends are complete with pin and clips.
In sizes 50 and 100 fork ends are complete with pin and circlip.
Material: galvanized steel. (Stainless Steel upon request)*

Von Größe 2,5 bis 25 werden die Gabelköpfe mit Stift und Clips geliefert.
Bei den Größen 50 und 100 verfügen die Gabelköpfe über Stift und Seegering
Material: Verzinkter Stahl (auf Wunsch INOX-Edelstahl).

RE
testa a snodo

RE
rod end

RE
Gelenkkopf

Taglia Size Größe	A	B	H1	H2	H3	D1	D2	d H7	M	CH	kg
UP2.5 *	14	10.5	43	15	20	Ø 28	Ø 15	Ø 10	M10	17	0.08
UP5	16	12	50	17	22	Ø 32	Ø 17.5	Ø 12	M12	19	0.12
UP10	19	13.5	57	19	25	Ø 36	Ø 20	Ø 14	M14	22	0.18
UP25	25	18	77	27	33	Ø 50	Ø 27.5	Ø 20	M20	30	0.44
UP50 *	37	25	110	36	51	Ø 70	Ø 40	Ø 30	M30X2	41	1.18
UP100 *	43	28	125	41	56	Ø 80	Ø 46	Ø 35	M36X2	50	1.72

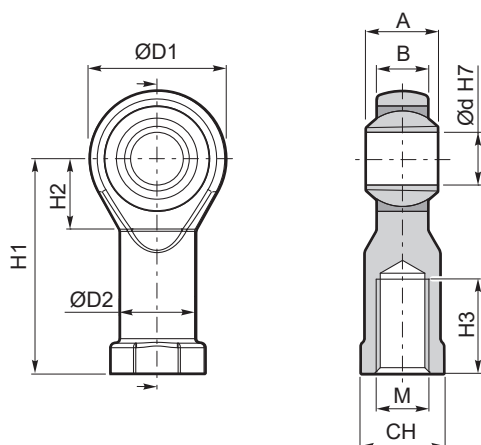

Nelle grandezze contrassegnate con * occorre richiedere l'opzione RE in fase d'ordine, perché non sono montabili sullo stelo standard.
ATTENZIONE: Usare solo con sistema anti-rotazione!
Materiale: acciaio

*In sizes marked * the RE option must be requested when ordering, as rod ends cannot be fitted to standard spindles.
WARNING: Only use with anti-rotation system!
Material: steel.*

Bei den mit * gekennzeichneten Größen muss bei der Bestellung die Option RE angefordert werden, da sie nicht auf einer Standardspindel montiert werden können
ACHTUNG: Nur mit Verdrehsicherungssystem verwenden!
Material: Stahl

AD
antirotazione

Il dispositivo di antirotazione vincola la rotazione della vite traslante attorno al proprio asse.

ATTENZIONE:

Il dispositivo è indispensabile nel caso in cui il carico applicato al martinetto non risulti guidato e con l'utilizzo dei terminali RE (teste a snodo). Funziona anche come sistema antisfilamento.

Non può essere utilizzato come arresto.

AD
antirotation device

The anti-rotation device constrains the rotation of the translating screw around its own axis.

WARNING:

The device is indispensable if the load applied to the jack is not guided and with the use of RE terminals (rod ends).

It also works as an escape protection system. It cannot be used as a stop.

AD
Verdrehsicherung

Die Verdrehsicherung verhindert die Drehung der stehenden Spindel um ihre eigene Achse.

ACHTUNG:

Die Vorrichtung ist unverzichtbar, wenn die auf das Spindelhubgetriebe einwirkende Last nicht geführt wird und RE-Endstücke (Kugelgelenkköpfe) verwendet werden.

Sie fungiert auch als Ausdrehsicherung. Sie darf nicht als Bremse verwendet werden.

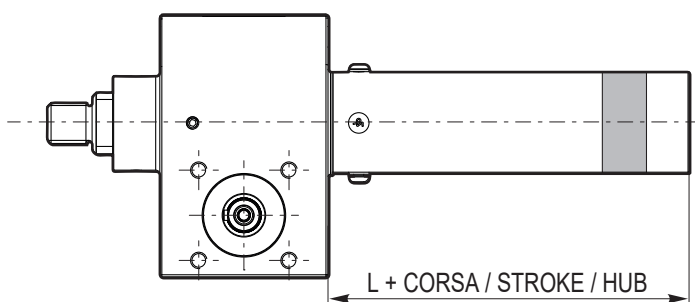

Taglia Size Größe	L
UP2.5	63
UP5	68
UP10	71
UP25	76
UP50	94
UP100	115

EP
protezione anti-sfilamento

La protezione anti-svitamento impedisce la fuoriuscita della vite dal martinetto.

ATTENZIONE:

Obbligatorio nella versione T con viti a ricircolo di sfere!

Non può essere utilizzato come arresto.

Non può essere montato in abbinamento al sistema antirotazione.

EP
escape protection

The escape protection prevents the screw from winding out of the gearbox.

WARNING:

Mandatory in the T version with ball screws!

Cannot be used as a stop.

Cannot be fitted in combination with the anti-rotation system.

EP
Ausdrehsicherung

Die Ausdrehsicherung verhindert das Herausdrehen der Gewindespindel aus dem Spindelhubgetriebe

ACHTUNG:

Sie ist bei der Ausführung T mit Kugelumlaufspindel obligatorisch. Sie darf nicht als Bremse verwendet werden.

Sie kann nicht gemeinsam mit dem Verdrehsicherungssystem montiert werden.

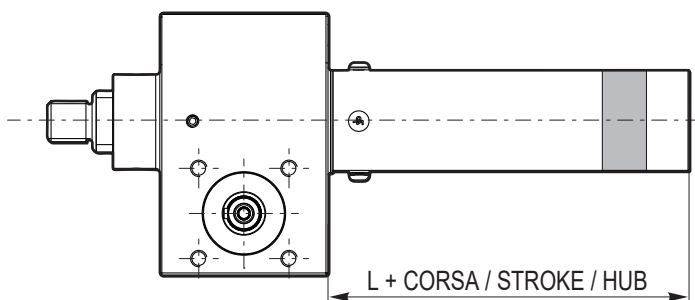

Taglia Size Größe	L
UP2.5	63
UP5	68
UP10	71
UP25	76
UP50	94
UP100	115

SN-R / SN-T
chiocciola di sicurezza

La chiocciola di sicurezza viene utilizzata per sostenere il carico in caso di usura della madrevite principale. Permette il controllo dell'usura del filetto evitando che si superi l'usura ammessa o il collasso del filetto.

SN-R

Nella versione rotante la chiocciola di sicurezza lavora in un solo senso, pertanto in fase d'ordine è necessario indicare il senso di carico in compressione o in trazione.

SN-T

Nella versione traslante la chiocciola di sicurezza lavora in entrambi i sensi e non è necessario indicare il senso di carico. Opzione non disponibile nella taglia 2.5.

SN-R / SN-T
safety nut

The safety nut is used to support the load in case of wear of the main nut. Allows thread wear to be monitored to avoid exceeding the permissible wear level and situations of thread collapse.

SN-R

In the rotating version the safety nut works in one direction only: specify compression or traction load at the time of the order.

SN-T

In the travelling version the safety nut works in both directions and it is not necessary to indicate the type of load. Option not available in size 2.5.

SN-R / SNT
Sicherheitsfangmutter

Die Sicherheitsfangmutter dient dazu, die Last zu stützen, wenn die Laufmutter verschlissen ist. Sie ermöglicht die Überprüfung des Gewindeverschleißes und verhindert, dass der zulässige Verschleißgrad überschritten wird oder das Gewinde versagt.

SN-R

Bei der rotierenden Ausführung arbeitet die Sicherheitsfangmutter nur in einer Richtung. Daher muss bei der Bestellung die Belastungsrichtung (Druck- oder Zugbelastung) angegeben werden

SN-T

Bei der stehenden Ausführung arbeitet die Sicherheitsfangmutter in beide Richtungen. Daher muss bei der Bestellung die Belastungsrichtung nicht angegeben werden. Diese Option ist für die Größe 2,5 nicht verfügbar.

SN-R

Carico in compressione
Compression-Pushing load
Druckbelastung

Carico in trazione
Traction-Pulling load
Zugbelastung

Taglia Size Größe	L
UP2.5	88
UP5	88
UP10	102
UP25	110
UP50	155
UP100	199

SN-T

Taglia Size Größe	D2	D3	L2	L8
UP10	39	66	75	15
UP25	46	85	83	15
UP50	60	125	118	18
UP100	85	138	145	18

IS
stelo maggiorato UP-R

In applicazioni soggette a carico di punta dove non è possibile ottenere la corsa voluta, in alternativa alla selezione di una taglia superiore, solo per la versione rotante "R", è possibile applicare steli maggiorati. Per ulteriori informazioni contattare il nostro servizio tecnico-commerciale.

IS
oversize spindle UP-R

In applications subject to buckling load where it is not possible to obtain the desired stroke, oversized spindles can be installed as an alternative to selecting a larger size, exclusively for rotating version "R". For further information contact our engineering-commercial department.

IS
verlängerte Gewindespindel UP-R

Bei Anwendungen mit Höchstlast, bei denen der gewünschte Hub nicht erreicht werden kann, kann als Alternative zur Auswahl einer größeren Größe nur für die rotierende Ausführung „R“ eine verlängerte Spindel verwendet werden. Wenden Sie sich für weitere Informationen an unseren vertriebstechnischen Kundendienst.

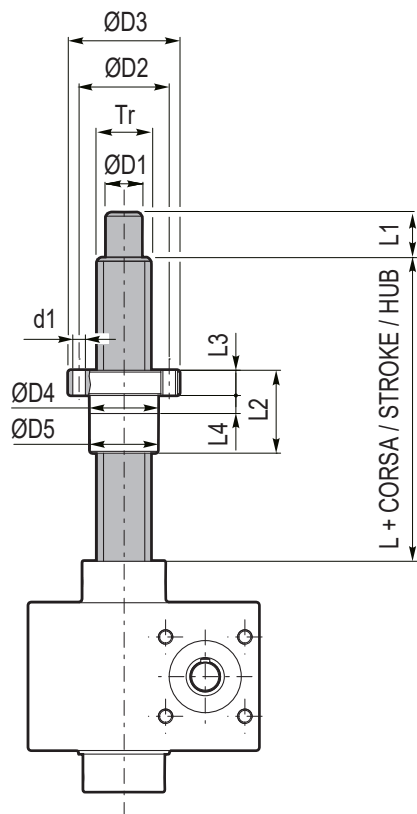

	UP2.5	UP5	UP10	UP25	UP50	UP100
Ød1	Ø 6	Ø 7	Ø 7	Ø 9	Ø 11	Ø 17
ØD1	Ø 12	Ø 15	Ø 20	Ø 25	Ø 40	Ø 55
ØD2	Ø 38	Ø 45	Ø 50	Ø 78	Ø 90	Ø 140
ØD3	Ø 48	Ø 55	Ø 60	Ø 95	Ø 110	Ø 180
ØD4	Ø 28	Ø 32	Ø 38	Ø 63	Ø 72	Ø 95
ØD5	Ø 27,8	Ø 31,8	Ø 37,8	Ø 63,8	Ø 71,8	Ø 94,8
L	64	64	66	95	117	Ø 130
L1	15	20	25	30	45	Ø 70
L2	44	44	46	73	97	Ø 100
L3	12	12	14	16	18	Ø 30
L4	8	8	10	12	30	Ø 30
Tr	18X4	20X4	30X6	40X7	55X9	70X10

FS
listelli di fissaggio

FS
fastening strips

FS
Befestigungsleisten

UP

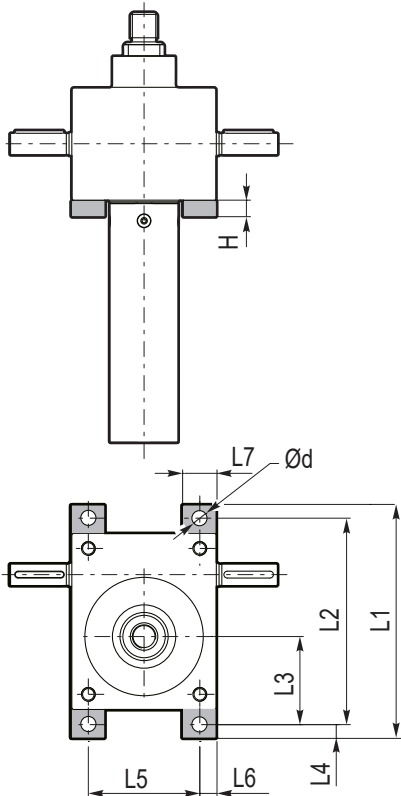

Taglia Size Größe	Ød	H	L1	L2	L3	L4	L5	L6	L7
UP2.5	Ø 6.5	10	90	75	29.5	7.5	38	6	12
UP5	Ø 8.5	10	120	100	41	10	52	9	18
UP10	Ø 8.5	10	140	120	50	10	63	10	20
UP25	Ø 11	12	170	150	64	10	81	12.5	25
UP50	Ø 13	16	230	204	90	13	115	15	30
UP100	Ø 22	25	270	236	101	17	131	18.5	37

Acc./Zub.

PBP
piastre supporto oscillante

PBP
pivot bearing plate

PBP
Schwenklagerplatten

UP

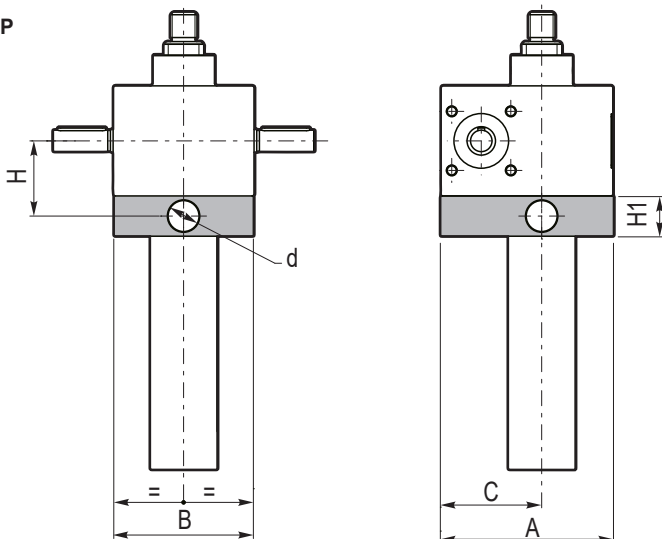

Taglia Size Größe	A	B	C	d	H	H1
UP2.5	60	50	38	Ø 8	35	20
UP5	78	72	48	Ø15	41	20
UP10	98	85	59	Ø18	50	25
UP25	128	105	75	Ø22	56	30
UP50	180	143	102	Ø25	78.5	40
UP100	200	163	117	Ø 28	105	50

MS
fine corsa meccanici

I fine corsa meccanici vengono fissati sul tubo di protezione dello stelo filettato, tramite l'apposito supporto che ne permette una regolazione di +/- 5 mm.
Gli interruttori standard prevedono un doppio contatto in scambio NO e NC

Riferimento codice d'ordinazione

2MS = 2 micro con contatto NO e NC

MS
mechanical limit switches

The mechanical limit switches are fixed to the screw protection tube by means of a special support that allows adjustment of +/- 5 mm. The standard switches have a double changeover NO and NC contact

Order code reference

2MS = 2 microswitches with NO and NC contact

MS
mechanische Endschalter

Die mechanischen Endschalter werden am Schutzrohr der Gewindespindel mithilfe einer Halterung angebracht, die eine Regulierung um +/- 5 mm ermöglicht.
Die Standardschalter verfügen über einen Doppelkontakt im NO- und NC-Wechsel

Referenz-Bestellcode

2MS = 2 Mikroschalter mit Kontakt NO und NC

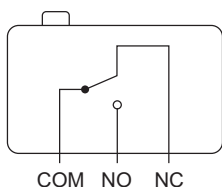

Dimensioni / Dimensions / Abmessungen			
Taglia Size Größe	D	H	L
UP2.5	Ø 46	105	91
UP5	Ø 50	107	93
UP10	Ø 55	109	98
UP25	Ø 70	112	104
UP50	Ø 80	121	125
UP100	Ø 110	130	156

ORIENTAMENTO

ORIENTATION

ORIENTIERUNG

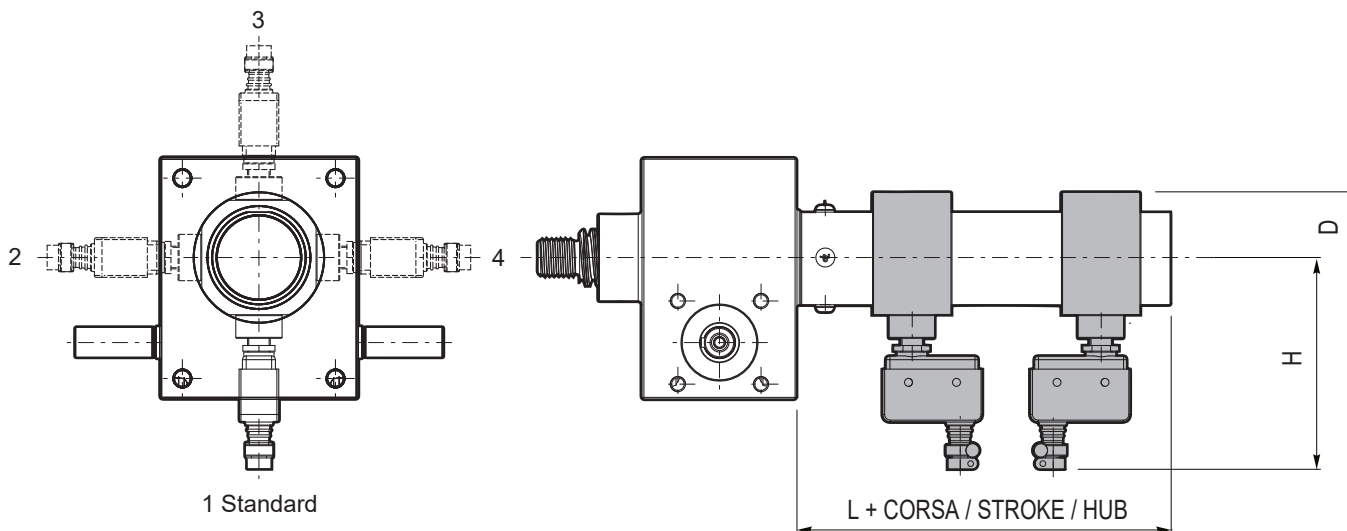

PLS
fine corsa induttivi

PLS
proximity (inductive) sensors

PLS
induktive Endschalter

NA + NC

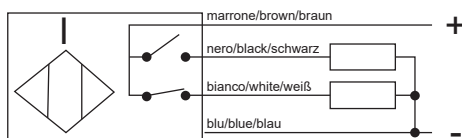

Dimensioni / Dimensions / Abmessungen			
Taglia Size Größe	D	H	L
UP2.5	Ø 46	62	91
UP5	Ø 50	64	93
UP10	Ø 55	67	98
UP25	Ø 70	71	104
UP50	Ø 80	78	125
UP100	Ø 110	88	156

Caratteristiche tecniche: Technical data: Technische Eigenschaften:	
Tensione di alimentazione (UB): Supply voltage (UB): Versorgungsspannung (UB):	5 ÷ 40 Vdc
Temperatura di funzionamento: Temperature range: Betriebstemperatur	- 25° ÷ + 75°C
Grado di protezione: Degree of protection: Schutzart:	IP67
Visualizzazione stato di uscita: Switch status indicator: Statusanzeige am Ausgang	LED giallo yellow LED gelbe LED

Acc./Zub.

ORIENTAMENTO

ORIENTATION

ORIENTIERUNG

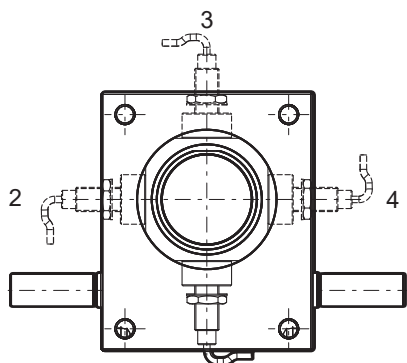

1 Standard

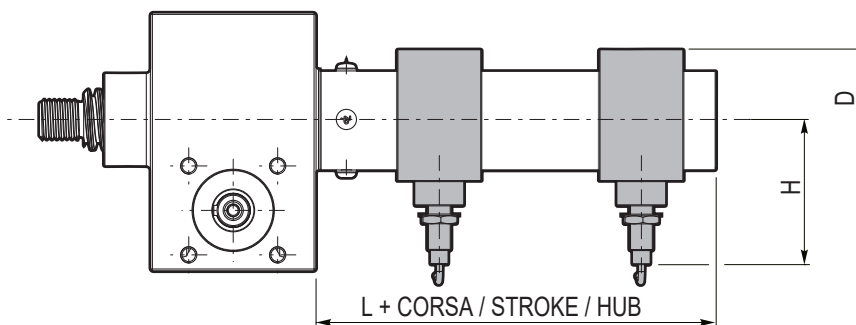

MLS
fine corsa magnetici

I fine corsa magnetici vengono fissati al tubo di protezione dello stelo filettato tramite appositi supporti, che consentono la regolazione della corsa.

In fase della regolazione della corsa, occorre prestare molta attenzione a non superare il limite indicato nella tabella sottostante per evitare che il martinetto raggiunga le posizioni estreme causando battute meccaniche.

Ulteriori informazioni sono riportate sul manuale di uso e manutenzione.

I sensori vengono montati nella posizione indicata a disegno, ma per esigenze di montaggio, possono essere ruotati attorno al canotto di protezione tramite l'apposito supporto.

Sono disponibili tre tipi di sensori:

Circuito Reed NC

Circuito con ampolla Reed normalmente chiusa protetta da varistore contro le sovratensioni generate all'apertura del circuito, e sistema di visualizzazione a LED.

Circuito Reed NO

Circuito con ampolla Reed normalmente aperta, protetta da varistore contro le sovratensioni generate all'apertura del circuito, e sistema di visualizzazione a LED.

Circuito NPN

Circuito con effetto di Hall con uscita NPN. Protetto contro l'inversione di polarità e contro picchi di sovratensione. Sistema di visualizzazione a LED.

MLS
magnetic limit switches

The magnetic limit switches are fixed to the screw protection tube by means of special supports that allow for stroke adjustment.

When adjusting the stroke, take care not to exceed the limit indicated in the table below to prevent the jack from reaching extreme positions causing contact with mechanical stops.

Further information can be found in the use and maintenance manual.

The sensors are fitted in the position indicated in the drawing, but for assembly requirements they can be rotated around the shield tube by means of the special support.

There are three types of sensor available:

NC Reed circuit

Circuit with normally closed reed switch protected by varistor against overvoltage generated when the circuit is opened, and LED display system.

NO Reed Circuit

Circuit with normally open reed switch protected by varistor against overvoltage generated when the circuit is opened, and LED display system.

NPN Circuit

Circuit with Hall effect with NPN output. Protected against polarity reversal and against peak overvoltage. LED display system. opened, and LED display system.

MLS
magnetische Endschalter

Die magnetischen Endschalter werden am Schutzrohr der Gewindespindel mithilfe einer Halterung angebracht, die eine Regulierung des Hubs ermöglicht.

Achten Sie beim Einstellen des Hubs darauf, den in nachstehender Tabelle aufgeführten Grenzwert nicht zu überschreiten, um zu vermeiden, dass das Spindelhubgetriebe Extrempositionen erreicht, die mechanische Schläge hervorrufen können. Weitere Informationen finden Sie in der Betriebs- und Wartungsanleitung.

Die Sensoren werden an der in der Zeichnung angegebenen Position montiert, können aber, wenn es aus montagetechnischen Gründen erforderlich ist, auch mit der entsprechenden Halterung um das Schutzrohr gedreht angebracht werden.

Es stehen drei Sensorentypen zur Verfügung:

Reed-NC-Kreislauf

Stromkreis mit normalerweise geschlossener Reed-Ampulle, die durch einen Varistor gegen beim Öffnen des Kreislaufs auftretende Überspannungen geschützt ist, und LED-Anzeigesystem.

Reed-NO-Kreislauf

Stromkreis mit normalerweise offener Reed-Ampulle, die durch einen Varistor gegen beim Öffnen des Kreislaufs auftretende Überspannungen geschützt ist, und LED-Anzeigesystem.

NPN-Kreislauf

Kreislauf mit Hall-Effekt und NPN-Ausgang. Geschützt gegen Umpolung und Überspannungsspitzen. LED-Anzeigesystem.

Tipo sensore Sensor type Sensortyp	Circuito Reed NC NC Reed Circuit Read-NC-Kreislauf	Circuito Reed NO NO Reed Circuit Reed-NO-Kreislauf	Circuito NPN NPN Circuit NPN-Kreislauf
Riferimento Codice d'ordinazione Order code reference Referenz-Bestellcode	2MLS0 2 Sensori circuito Reed NC (versione standard) 2 Sensors circuit Reed NC (standard version) 2 Sensoren mit Reed-NC-Kreislauf (Standardausführung)	2MLS1 2 Sensori circuito Reed NO 2 Sensors circuit Reed NO 2 Sensoren mit Reed-NO-Kreislauf	2MLS2 2 Sensori NPN 2 Sensors NPN 2 NPN-Sensoren
Tensione in DC / DC voltage / Gleichstrom	3 / 110 V	3 / 30 V	6 / 30 V
Tensione in AC / AC voltage / Wechselstrom	3 / 110 V	3 / 30 V	-
Corrente / Current / Strom bei 25 °C	0,5 A	0,1 A	0,20 A
Potenza / Power / Leistung	20 VA	6 VA	4 W
Cavo alimentazione / Supply cable / Stromkabel	PVC 2 x 0,14 mm	PVC 2 x 0,14 mm	PVC 3 x 0,14 mm
Lunghezza cavo / Cable length / Kabellänge	2500 mm	2.500 mm	2.500 mm
Protezione / Protection / Schutzart	IP67	IP67	IP67
Schema circuito / Circuit diagram / Schaltplan			

MLS
 fine corsa magnetici

MLS
 magnetic limit switches

MLS
 magnetische Endschalter

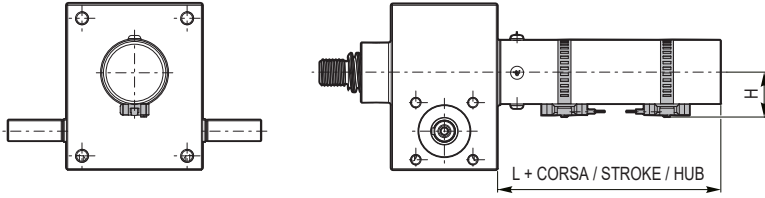

Dimensioni / Dimensions / Abmessungen

Taglia Size Größe	H	L
UP2.5	25	63
UP5	26	68
UP10	29	71
UP25	34	76
UP50	42	94
UP100	55	115

B
soffietto protezione vite

IMPORTANT! Il montaggio del soffietto deve essere definito in fase d'ordine in quanto comporta variazioni sul martinetto. In caso di montaggi orizzontali i soffietti devono essere dotati di anelli di appoggio per evitare l'usura dovuta ad attrito con la vite.

Variazione di dimensioni con l'inserimento del soffietto.

B
screw protection bellows

IMPORTANT! Assembly of the bellows must be defined at the time of ordering as it involves variations to the jack. In case of horizontal assembly the bellows must be fitted with support rings to avoid wear due to chaffing against the screw.

Size variation with insertion of the bellows.

B
Faltenbalg zum Schutz der Gewindespindel

WICHTIG! Die Montage des Faltenbalgs muss zum Zeitpunkt der Bestellung festgelegt werden, da sie Veränderungen am Spindelhubgetriebe mit sich bringt. Bei horizontaler Montage müssen die Faltenbälge mit Stützringen ausgestattet sein, um Verschleiß durch Reibung an der Gewindespindel zu vermeiden.

Veränderte Abmessungen beim Einsetzen des Faltenbalgs.

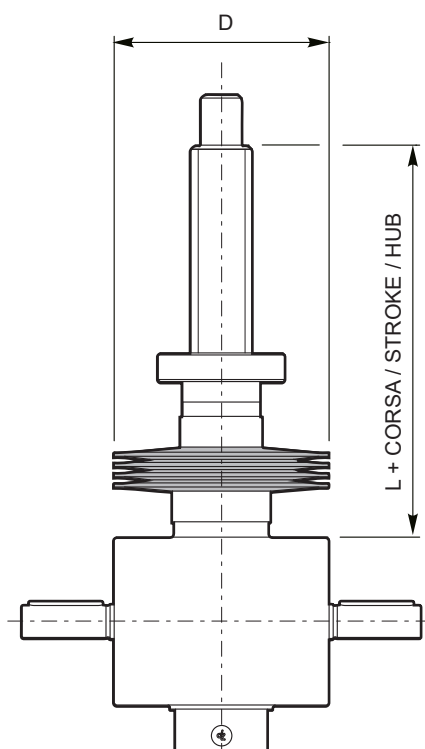
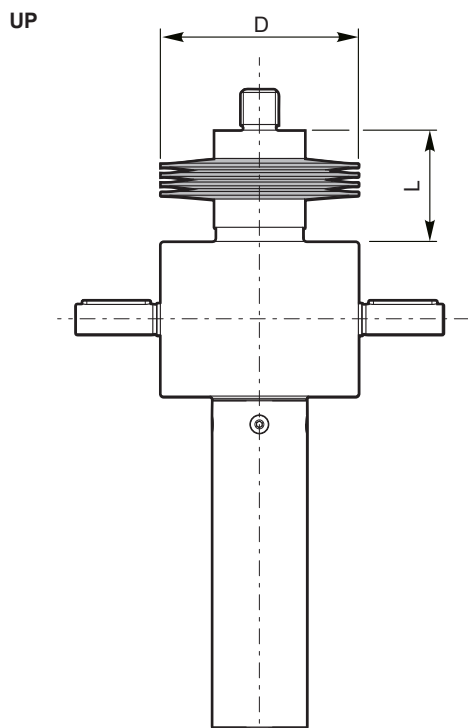

Versione traslante / Travelling version / Stehende Ausführung		
Taglia Size Größe	D	L
UP2.5	Ø 60	36 + ((1.14x corsa)-corsa) 36 + ((1.14 x stroke)- stroke) 36 + ((1,14 x Hub) – Hub)
UP5	Ø 70	36 + ((1.14x corsa)-corsa) 36 + ((1.14 x stroke)- stroke) 36 + ((1,14 x Hub) – Hub)
UP10	Ø 80	40 + ((1.14x corsa)-corsa) 40 + ((1.14 x stroke)- stroke) 40 + ((1,14 x Hub) – Hub)
UP25	Ø 105	46 + ((1.1 x corsa)-corsa) 46 + ((1.1 x stroke)- stroke) 46 + ((1,1 x Hub) – Hub)
UP50	Ø 125	56 + ((1.09 x corsa)-corsa) 56 + ((1.09 x stroke)- stroke) 56 + ((1,09 x Hub) – Hub)
UP100	Ø 150	65 + ((1.09 x corsa)-corsa) 65 + ((1.09 x stroke)- stroke) 65 + ((1,09 x Hub) – Hub)

Versione rotante / Rotating version / Rotierende Ausführung		
Taglia Size Größe	D	L
UP2.5	Ø 60	76 + ((1.14x corsa)-corsa) 76 + ((1.14 x stroke)- stroke) 76 + ((1,14 x Hub) – Hub)
UP5	Ø 70	76 + ((1.14x corsa)-corsa) 76 + ((1.14 x stroke)- stroke) 76 + ((1,14 x Hub) – Hub)
UP10	Ø 80	82 + ((1.14x corsa)-corsa) 82 + ((1.14 x stroke)- stroke) 82 + ((1,14 x Hub) – Hub)
UP25	Ø 105	90 + ((1.1 x corsa)-corsa) 90 + ((1.1 x stroke)- stroke) 90 + ((1,1 x Hub) – Hub)
UP50	Ø 125	130 + ((1.09 x corsa)-corsa) 130 + ((1.09 x stroke)- stroke) 130 + ((1,09 x Hub) – Hub)
UP100	Ø 150	150 + ((1.09 x corsa)-corsa) 150 + ((1.09 x stroke)- stroke) 150 + ((1,09 x Hub) – Hub)

TS
alberi di trasmissione

Alberi con mozzi a morsetto:

- Pratico montaggio radiale tramite mozzi a morsetto.
- Semplicità di montaggio e di regolazione grazie ai morsetti.
- Fornibile a richiesta con sede linguetta.
- Materiale: alluminio ad alta resistenza (INOX su richiesta).
- Stella in elastomero senza gioco con durezza Shore 64D.
- Temperatura di funzionamento: da -10°C fino a +70°C

TS
trasmision shafts

Shafts with clamp hubs:

- *Practical radial assembly with clamp hubs.*
- *Easy assembly and adjustment thanks to the clamps.*
- *Can be supplied with keyway on request.*
- *Material: high strength aluminium (Stainless Steel on request).*
- *Backlash-free elastomeric spider with Shore 64D hardness.*
- *Operating temperature: from -10°C up to +70°C*

TS
Antriebswellen

Wellen mit Klemmnaben:

- Praktische radiale Montage mithilfe von Klemmnaben.
- Einfache Montage und Einstellung mithilfe der Klemmen.
- Auf Wunsch mit Zungensitz lieferbar.
- Material: hochfestes Aluminium (auf Wunsch INOX-Edelstahl).
- Elastomerstern ohne Spiel mit Härtegrad Shore 64D.
- Betriebstemperatur: von -10 °C bis +70 °C

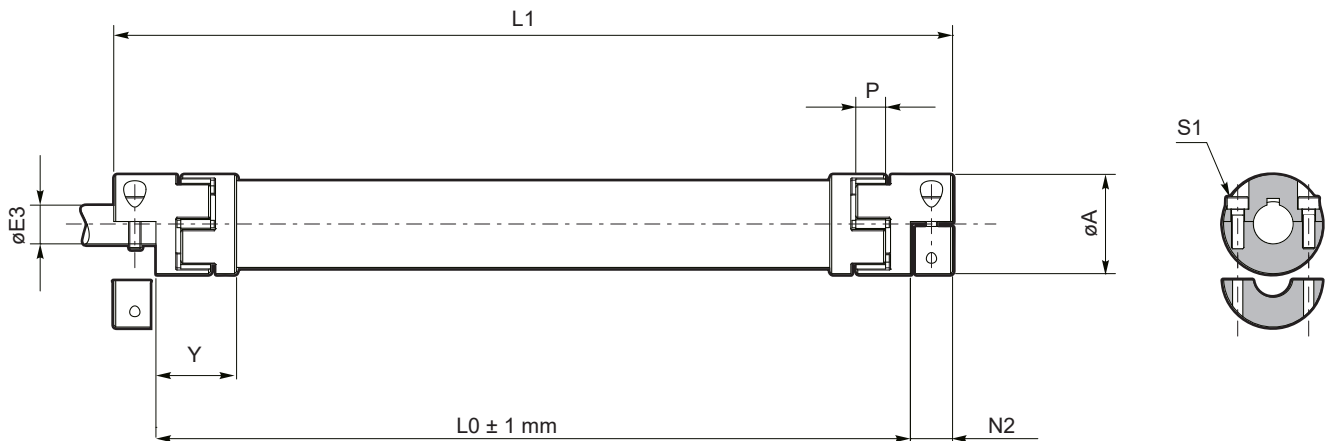

L0 = distanza tra gli alberi dei martinetti o dei rinvii da unire

L0 = distance between the shafts of the jacks or bevel gearboxes to be joined

L0 = abstand zwischen den Wellen der zu verbindenden Hebeböcke oder Umlenkungen

Taglia Size Größe	A	E3 Min.	E3 Max	N2	P	Y	Dt	L1	Peso Allunga Extension weight Gewicht der Verlängerung [Kg/m]	Peso tot. Total weight Gesamtgewicht [Kg]	L0 [mm]	S1	Coppia di serraggio Tightening torque Anzugs-drehmoment [Nm]
14	Ø 30	6	15	14	12	20.5	30	28 + L0	1.06	0.03 + Peso allunga 0.03 + Extension weight 0.03 + Gewicht der Verlängerung	58	M4	3.1
19	Ø 40	8	20	19	16	30.5	35	38 + L0	1.27	0.15 + Peso allunga 0.15 + Extension weight 0.15 + Gewicht der Verlängerung	95	M5	6.2
24	Ø 55	10	30	22	18	37.5	50	44 + L0	1.91	0.28 + Peso allunga 0.28 + Extension weight 0.28 + Gewicht der Verlängerung	113	M6	10.5
28	Ø 65	14	35	25	20	41	60	50 + L0	3.34	0.55 + Peso allunga 0.55 + Extension weight 0.55 + Gewicht der Verlängerung	131	M8	25
38	Ø 80	15	45	34	24	46	70	68 + L0	5.099	0.98 + Peso allunga 0.98 + Extension weight 0.98 + Gewicht der Verlängerung	161	M8	25

Taglia Size Größe	Coppie trasmissibili bloccaggio a morsetto tipo C Transmissible Torques Type C Clamp Locking Mit Klemmverbindung vom Typ C Übertragbare Drehmomente [Nm]																						
	6	8	9	10	11	12	14	15	16														
14																							
19		14	16	17	19	21	24	26	28	31	33	35	33	36									
24				20	22	24	28	30	32	36	38	40	44	48	50	57	61						
28							55	59	63	71	75	79	86	94	98	110	118	126	137	128			
38								59	63	71	75	79	86	94	98	110	118	126	137	149	157	165	177

Acc./Zub.

TS
alberi di trasmissione

TS
transmission shafts

TS
Antriebswellen

DIAGRAMMA DELLE VELOCITA' / SPEED DIAGRAM / GESCHWINDIGKEITSDIAGRAMM

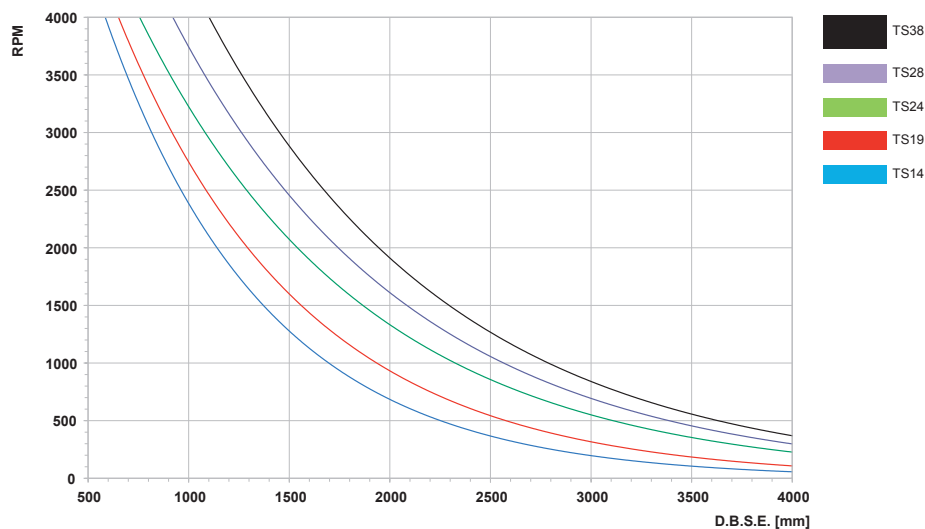

Tipo Type Typ	Lunghezza minima Minimum length Minimale Länge [mm]
TS14	86
TS19	133
TS24	157
TS28	181
TS38	229

SIGLA DI ORDINAZIONE / ORDERING KEY / BESTELLSCHLÜSSEL

1	2	3	4
Taglia Size Größe	Lunghezza Lenght Länge L1 [mm]	Diametro foro giunti Couplings diameter Durchmesser der Verbindungsbohrungen d [mm]	Diametro foro giunti Couplings diameter Durchmesser der Verbindungsbohrungen d [mm]
TS19	500	16	16

TS14
TS19
TS24
TS28
TS38

Lunghezza L1 Lenght L1 Länge L1 [mm]

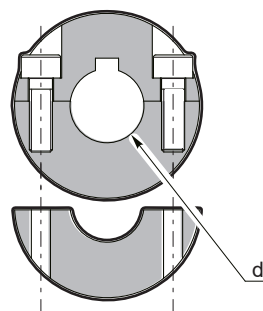
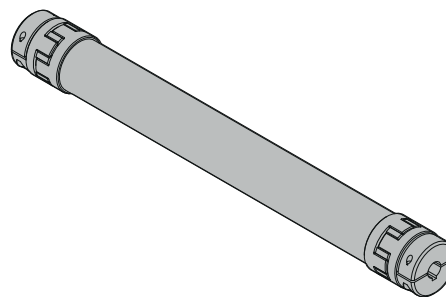

d = Foro giunto (passaggio albero)
L1= Lunghezza totale albero comprensivo di giunti

d = Joint hole (shaft passage)
L1 = Total shaft length with couplings

d = Verbindungsloch (Wellendurchgang)
L1= Gesamtlänge der Welle mit Kupplungen

TS
alberi di trasmissione

TS
transmission shafts

TS
Antriebswellen

UP

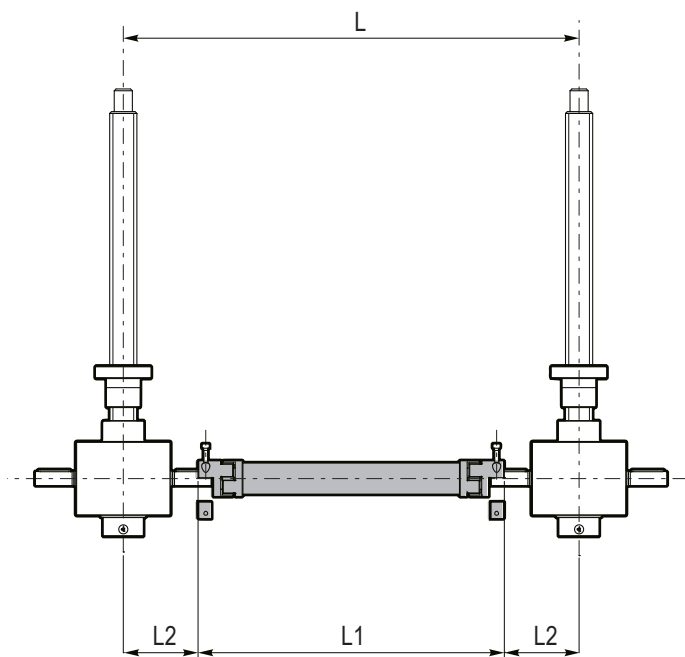

$$L1 = L - (2 * L2)$$

L = Interasse martinetti
L1= Lunghezza totale albero comprensivo di giunti

L = Jacks centre distance
L1 = Total shaft length with couplings

L = Abstand der Spindelhubgetriebe
L1= Gesamtlänge der Welle mit Kupplungen

Taglia Size Größe	Tipo Albero Shaft Type Wellenart	L2
UP2.5	TS14	32
UP5	TS 14	46
	TS 19	41
	TS 24	38
UP10	TS 14	56
	TS 19	51
	TS 24	48
UP25	TS 19	78,5
	TS 24	75,5
	TS 28	72,5
UP50	TS 24	98
	TS 28	95
	TS 38	86
UP100	TS 28	125
	TS 38	116

Acc./Zub.

GR
giunto

GR
couplings

GR
Kupplung

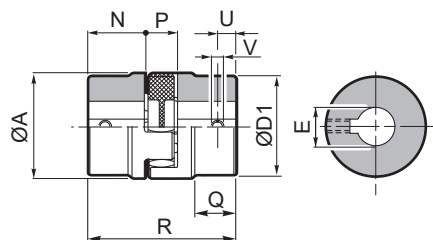
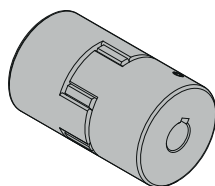







Taglia Size Größe	A	D1	E Max	N	P	Q	R	U	V	Peso Weight Gewicht [Kg]
14	30	-	16	11.5	12	-	35	5	M4	0.03
19	40	-	25	25	16	-	66	10	M5	0.15
24	55	53	35	30	18	20	78	10	M5	0.28
28	65	63	40	35	20	24	90	15	M8	0.55
38	80	78	48	45	24	33	114	15	M8	0.98

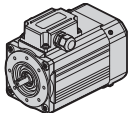

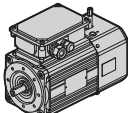
Motori applicabili
Applicable motors
Anwendbare Motoren

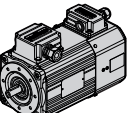

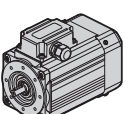
		Motori elettrici CA SM	AC Electric motors SM	AC Motoren SM	D2
		Motori elettrici CA autofrenanti SMT..BR	AC Electric motors with brake SMT..BR	AC Motoren selbstbremsend SMT..BR	D10
		Motori elettrici CA servoventilati SMT..SV	AC Electric Motors with forced-ventilation SMT..SV	AC Motoren servobelüftet SMT..SV	D14
		Motori elettrici CA SM..UL/CSA	AC Electric motors SM..UL/CSA	AC Motoren SM..UL/CSA	D18

Mot

Questa sezione annulla e sostituisce ogni precedente edizione o revisione. Qualora questa sezione non Vi sia giunta in distribuzione controllata, l'aggiornamento dei dati ivi contenuto non è assicurato. **In tal caso la versione più aggiornata è disponibile sul nostro sito internet www.transtecno.com**

*This section replaces any previous edition and revision. If you obtained this catalogue other than through controlled distribution channels, the most up to date content is not guaranteed. **In this case the latest version is available on our web site www.transtecno.com***

Caratteristiche tecniche

Technical characteristics

Technische Merkmale

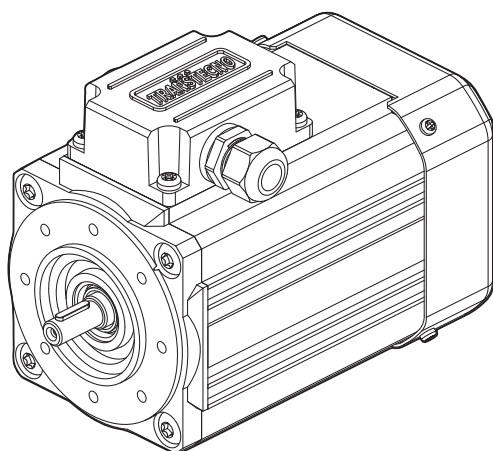

SM .. TEFC

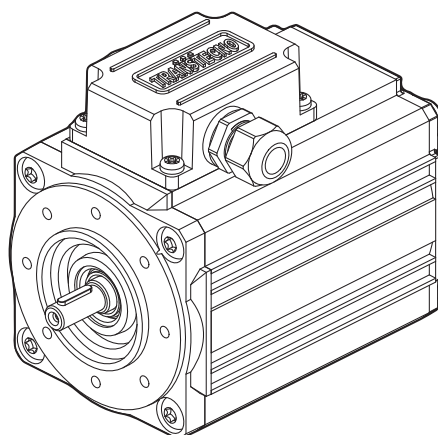

SM .. TENV



I motori delle serie SMT ed SMM hanno le seguenti caratteristiche principali:

- Costruzione compatta
- Motorizzazioni in corrente alternata monofase e trifase
- Carcassa estrusa in alluminio anodizzato nero
- Motore elettrico CA con grado di protezione IP66
- Rumorosità e vibrazioni contenute
- Isolamento termico di classe F
- Flangia motore IEC B14
- Temperatura ambiente: -20°C / + 40°C
- Disponibili sia nella versione ventilata TEFC (servizio S1) che non ventilata TENV (servizio S3)
- Protezioni termiche PTO 150°C per le taglie 56, 63, 71, 80 e 90.
- SMT56, SMT63, SMT71, SMT80 e SMT90 adatti al funzionamento con alimentazione da inverter.
- SMT80 e SMT90 conformi alla classe di rendimento IE3.
- Cava esagonale su albero motore lato NDE.
- Condensatore di marcia sempre cablato ad esclusione della taglia SMM50.
- La tolleranza di tensione è $\pm 10\%$ per tutti i motori ad esclusione della taglia 50 ($\pm 5\%$).
- Disponibili nelle versioni autofrenante, servoventilata e con certificazione UL/CSA.

SMT and SMM motor range has the following main features:

- *Compact design*
- *AC single phase and three phase motors available*
- *Black anodized extruded aluminium housing*
- *AC electric motor in IP66 protection Standard*
- *Low noise and vibrations*
- *Class F insulation Standard*
- *Motor flange IEC B14*
- *Ambient temperature: -20°C / +40°C*
- *Fan cooled TEFC (duty S1) and not ventilated TENV (duty S3) versions available*
- *PTO 150°C thermal protection for motor sizes 56, 63, 71, 80 and 90.*
- *SMT56, SMT63, SMT71, SMT80 and SMT90 are suitable to be driven by inverter.*
- *SMT80 and SMT90 in compliance to the Standard efficiency class IE3*
- *Motor shaft hexagon socket on the NDE side.*
- *Running capacitor always connected, except for SMM50.*
- *The voltage tolerance is $\pm 10\%$ for all motors, except for size 50 ($\pm 5\%$).*
- *Brake motors, forced ventilation motors and UL/CSA compliance versions available.*

Die Motoren der Serien SMT und SMM haben die folgenden Hauptmerkmale:

- kompakte Bauweise
- einphasige und dreiphasige Wechselstrommotoren
- schwarz eloxiertes, stranggepresstes Aluminiumgehäuse
- AC-Elektromotor mit Schutzart IP66
- geräusch- und vibrationsarm
- Wärmedämmung der Klasse F
- Motorflansch IEC B14
- Umgebungstemperatur: -20°C / + 40°C
- erhältlich in den Ausführungen belüftet TEFC (Service S1) und unbelüftet TENV (Service S3)
- thermische Schutzvorrichtungen PTO 150°C für die Größen 56, 63, 71, 80 und 90.
- SMT56, SMT63, SMT71, SMT80 und SMT90 für den Umrichterbetrieb geeignet.
- SMT80 und SMT90 entsprechen der Effizienzklasse IE3.
- Sechskantausparung auf der Motorwelle auf der NDE-Seite.
- Betriebskondensator immer verdrahtet, außer bei der Größe SMM50.
- die Spannungstoleranz beträgt $\pm 10\%$ für alle Motoren außer Größe 50 ($\pm 5\%$).
- erhältlich in selbstbremsenden, servo-belüfteten und UL/CSA-zertifizierten Versionen.

Motori elettrici CA - SM

AC Electric motors - SM

AC Motoren - SM

Simbologia AC

AC Symbols

Symbole AC

P_n [kW] Potenza nominale	<i>Rated power</i>	Nennleistung
I_n [A] Corrente nominale (a 400V)	<i>Rated current (at 400V)</i>	Nennstrom (bei 400V)
M_n [Nm] Coppia nominale	<i>Rated torque</i>	Nenn Drehmoment
n_n [rpm] Velocità nominale	<i>Rated speed</i>	Nenngeschwindigkeit
LR [dB] Livello di rumorosità	<i>Noise Level</i>	Geräuschpegel
M_s / M_n Rapporto coppia spunto / coppia nominale	<i>Ratio start torque / rated torque</i>	Verhältnis Anlaufmoment / Nennmoment
M_k / M_n Rapporto coppia massima / coppia nominale	<i>Ratio max torque / rated torque</i>	Verhältnis maximales Drehmoment / Nenn Drehmoment
M_{sel} / M_n Rapporto coppia di sella (minima) / coppia nominale	<i>Ratio saddle torque / rated torque</i>	Verhältnis von Satteldrehmoment (Minimum) / Nenn Drehmoment
I_s / I_n Rapporto corrente di spunto / corrente nominale	<i>Ratio start current / rated current</i>	Verhältnis Einschaltstrom / Nennstrom
cosφ Fattore di potenza al carico nominale	<i>Power factor at rated torque load</i>	Leistungsfaktor bei Nennlast
η Rendimento al carico nominale	<i>Efficiency at rated torque load</i>	Wirkungsgrad bei Nennlast
S Servizio	<i>Duty</i>	Service
M_b [Nm] Coppia frenante	<i>Braking torque</i>	Bremsmoment
P_{sf} [W] Potenza assorbita servoventola	<i>Absorbed servo fan power</i>	Leistungsaufnahme Servolüfter

Dati tecnici

Technical data

Technische Daten

SMT Motori trifase / Three phase motors / Drehstrommotoren

(230-400 V / 50 Hz) poli / poles / polig 4

Tipo Type Typ	P _n [kW]	M _n [Nm]	n _n [min ⁻¹]	I _n (400V) [A]	η %	cosφ	M _s /M _n	I _s /I _n	M _k /M _n	PTO	S TEFC	S TENV
5014	0.04	0.30	1290	0.25	34.0	0.68	1.65	1.75	1.70	-	S1	S3 30%
5024	0.06	0.44	1300	0.35	35.7	0.69	1.55	1.80	1.60			
5034	0.09	0.65	1315	0.54	38.0	0.64	1.80	2.00	1.85			
5044	0.12	0.87	1315	0.64	43.0	0.63	1.80	2.00	1.80			
5624	0.09	0.64	1345	0.45	46.5	0.62	2.50	2.40	2.70	PTO 150°	S1	S3 50%
5634	0.12	0.89	1300	0.45	52.0	0.74	1.90	2.40	1.90			
5644	0.18	1.26	1360	0.69	59.0	0.65	2.50	3.00	2.60			
5654	0.25	1.80	1330	0.93	59.0	0.66	2.50	2.80	2.60			
6324	0.18	1.26	1360	0.69	57.0	0.66	2.50	2.90	2.50			
6334	0.25	1.74	1375	0.94	62.0	0.64	2.80	3.00	2.80			
6344	0.37	2.60	1360	1.24	65.3	0.66	2.70	3.00	2.70			
7124	0.37	2.52	1400	1.10	67.9	0.72	2.75	4.20	2.75			
7134	0.55	3.76	1395	1.55	70.2	0.73	2.90	4.40	2.90			
7144	0.75	5.09	1405	2.00	74.0	0.73	2.90	5.00	2.90			
IE3	8024 IE3	0.75	4.96	1440	1.94	82.5	0.68	3.6	6.00	3.70	S1	S3 70%
	8034 IE3	1.1	7.25	1450	2.91	84.1	0.65	4.0	6.80	4.40		S3 75%
	9024 IE3	1.5	10.0	1430	3.48	85.3	0.73	3.2	6.30	3.50		
	9034 IE3	2.2	14.9	1410	4.68	86.7	0.79	3.0	6.20	3.30		

SMM Motori monofase / Single phase motors / Einphasenmotoren

(230 V / 50 Hz) poli / poles / polig 4

Tipo Type Typ	P _n [kW]	M _n [Nm]	n _n [min ⁻¹]	I _n (230V) [A]	η %	cosφ	M _s /M _n	I _s /I _n	M _k /M _n	Cond./Cap./Kond. [μF]	PTO	S TEFC	S TENV
5014	0.04	0.27	1390	0.60	33.4	0.88	0.74	1.60	1.55	8.0	-	S1	S3 30%
5024	0.06	0.42	1380	0.89	34.3	0.85	0.76	1.70	1.50	12.0			
5034	0.09	0.63	1375	1.10	40.0	0.89	0.80	1.70	1.45	16.0			
5624	0.09	0.63	1370	0.82	48.6	0.98	0.72	1.70	1.45	6.3			
5634	0.12	0.83	1380	1.06	50.3	0.98	0.75	2.10	1.65	9.0	PTO 150°	S1	S3 50%
5644	0.18	1.25	1375	1.50	53.8	0.97	0.70	2.20	1.58	12.5			
6324	0.18	1.33	1290	1.50	54.5	0.97	1.00	1.80	1.45	12.0			
6334	0.25	1.85	1290	1.95	56.8	0.98	0.93	1.90	1.50	16.0			
7124	0.37	2.72	1300	2.78	58.6	0.99	0.77	2.00	1.35	20.0			
7134	0.55	3.95	1330	3.54	68.9	0.98	0.66	2.40	1.40	25.0			
8024	0.75	5.31	1350	4.93	67.4	0.98	0.67	2.50	1.54	35.0			

Per dimensioni e ulteriori dati consultare la documentazione disponibile sul sito www.transtecno.com
For dimensions and further data, please see the documentation available on the website www.transtecno.com
Abmessungen und weitere Daten entnehmen Sie bitte der Dokumentation auf der Website www.transtecno.com

Mot

3~

SMT50.. - B14 - TEFC / TENV

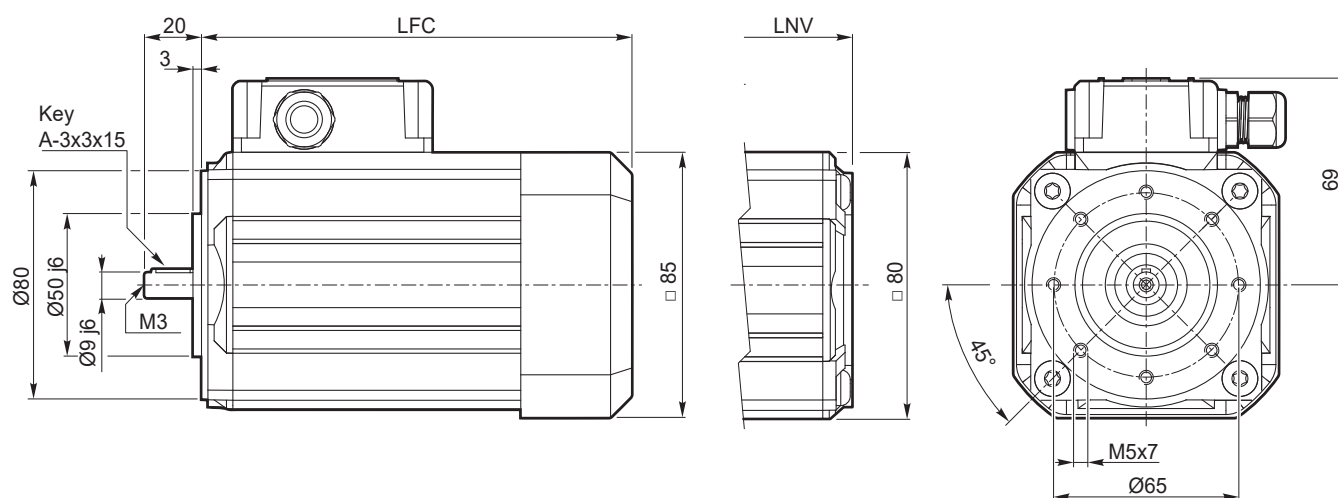

SMT	... TEFC		... TENV	
	LFC	kg	LNV	kg
5014	135.5	2.3	108.5	2.2
5024	150.5	2.7	123.5	2.6
5034	175.5	3.5	148.5	3.4
5044	200.5	4.2	173.5	4.1

3~

SMT56.. - B14 - TEFC / TENV

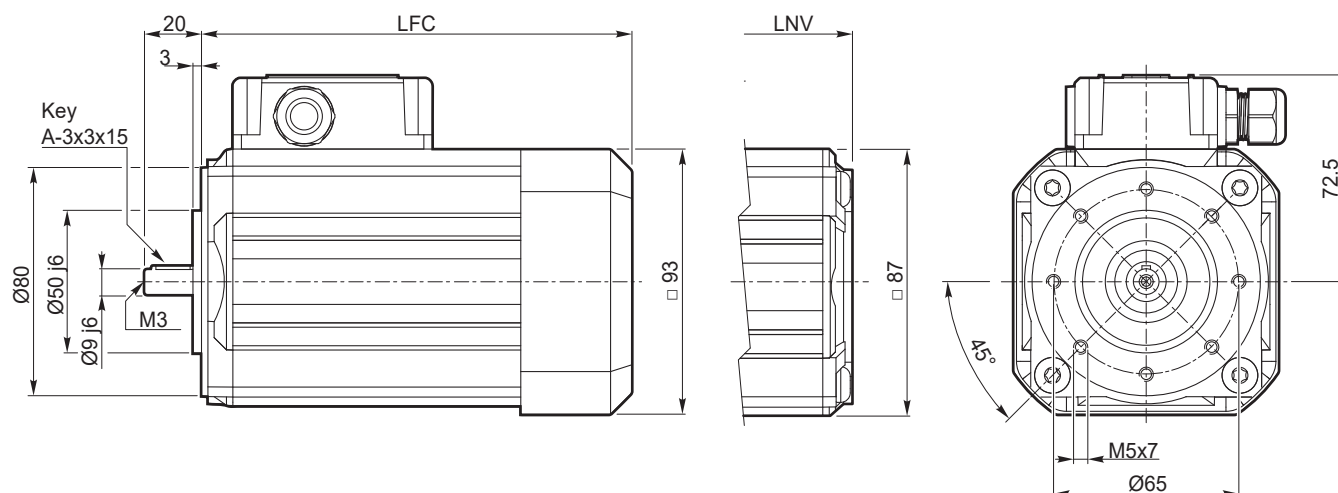

SMT	... TEFC		... TENV	
	LFC	kg	LNV	kg
5624	141	2.9	117	2.8
5634	151	3.2	127	3.1
5634 IE2	171	3.8	-	-
5644	186	4.4	162	4.3
5654	206	5.1	182	5.0

3~

SMT63.. - B14 - TEFC / TENV

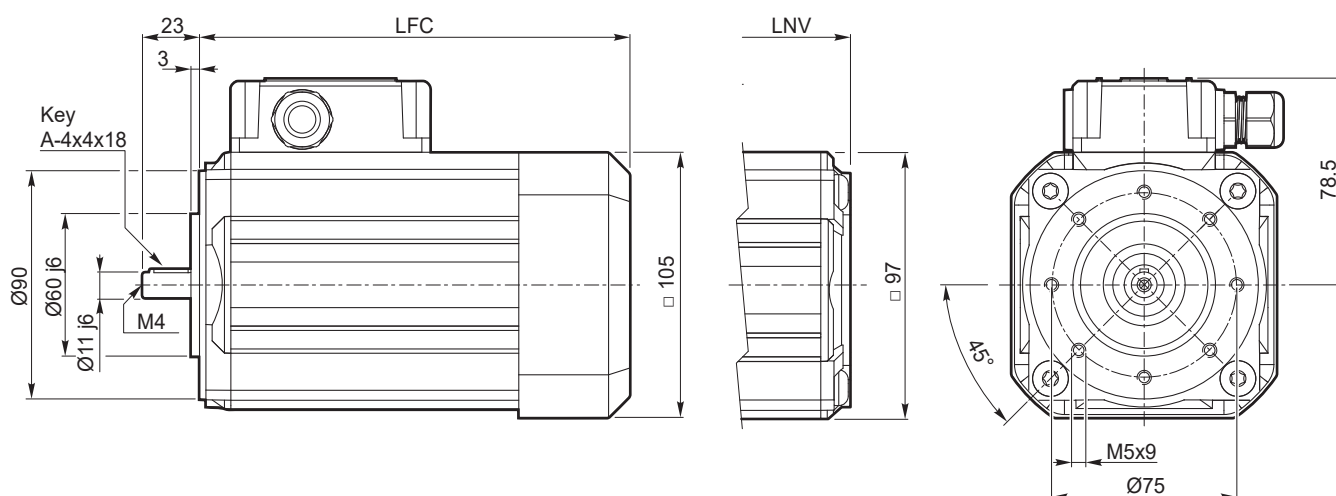

SMT	... TEFC		... TENV	
	LFC	Kg	LNV	Kg
6324	165.5	4.3	138.5	4.2
6324 IE2	180.5	4.9	-	-
6334	180.5	5.0	153.5	4.9
6334 IE2	205.5	6.1	-	-
6344	205.5	6.2	178.5	6.1

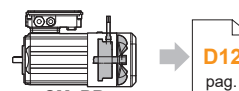

SM.BR..
Motori autofrenanti
Brake motors
Selbstbremsende Motoren

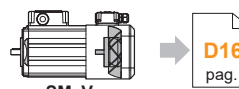

SM..V..
Motori servoventilati
Motors with forced-ventilation
Servobelüftete Motoren

3~

SMT71.. - B14 - TEFC / TENV

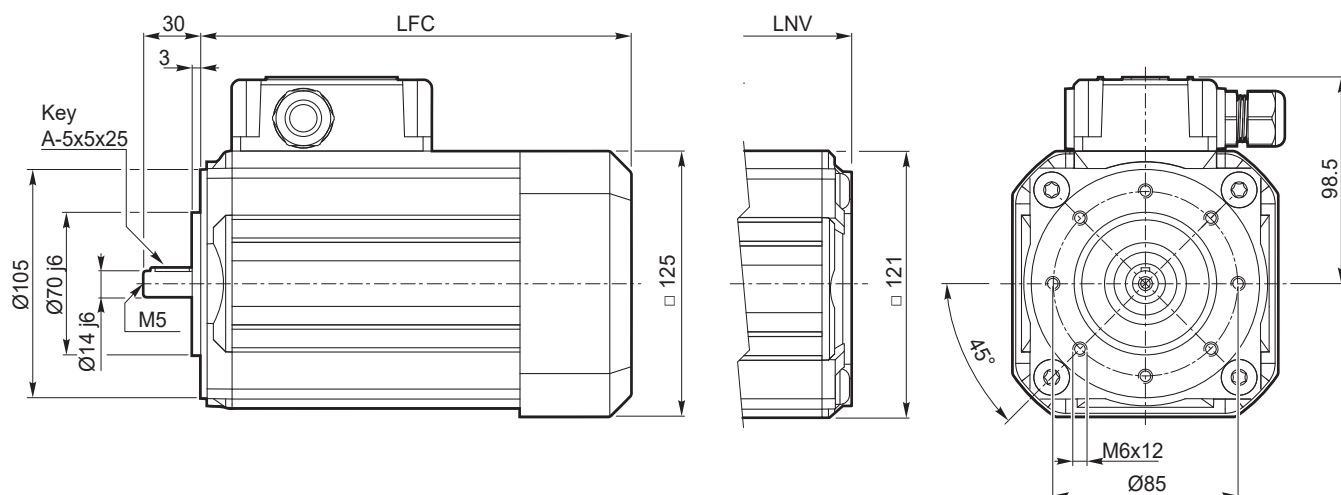

SMT	... TEFC		... TENV	
	LFC	Kg	LNV	Kg
7124	174	6.6	145.5	6.4
7124 IE2	189	7.5	-	-
7134	189	7.7	160.5	7.5
7134 IE2	214	9.2	-	-
7144	214	9.4	185.5	9.2

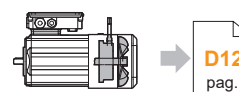

SM.BR..
Motori autofrenanti
Brake motors
Selbstbremsende Motoren



SM..V..
Motori servoventilati
Motors with forced-ventilation
Servobelüftete Motoren

Mot

3~

SMT80.. - B14 - TEFC / TENV

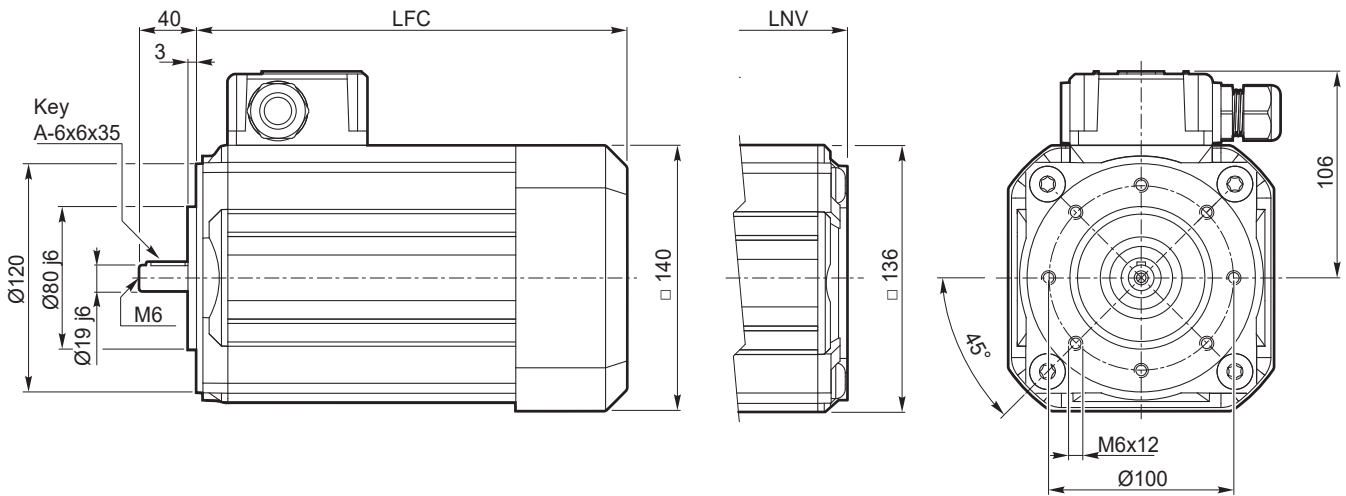

SMT	... TEFC		... TENV	
	LFC	kg	LNV	kg
8024	233	11.8	196	11.5
8034	283	16.8	246	16.5

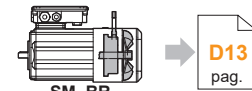

D13 pag.

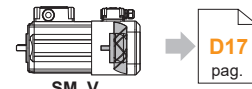

D17 pag.

3~

SMT90.. - B14 - TEFC / TENV

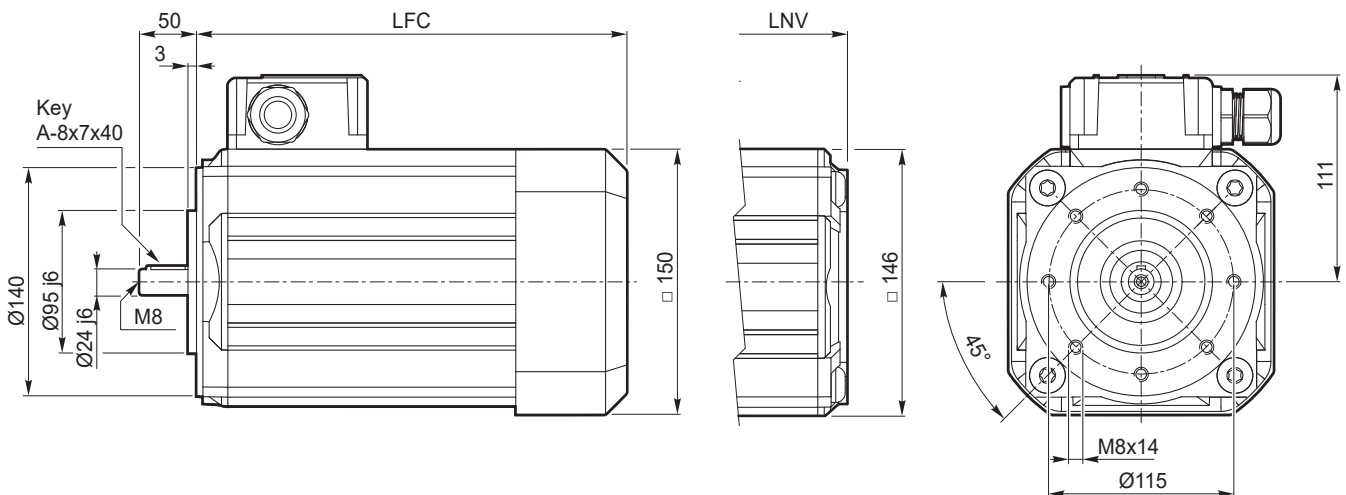

SMT	... TEFC		... TENV	
	LFC	kg	LNV	kg
9024	283	18.2	246	17.9
9034	313	21.5	276	21.2

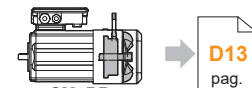

D13 pag.

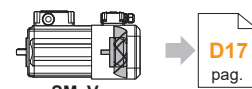

D17 pag.

1 ~

SMM50.. - B14 - TEFC / TENV

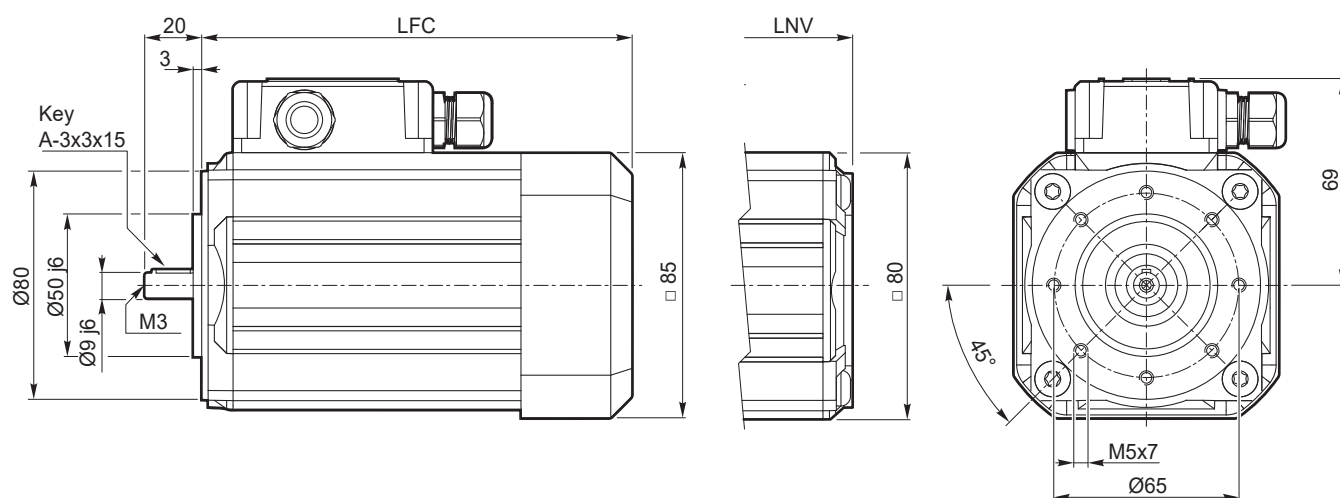

SMM	... TEFC		... TENV	
	LFC	kg	LNV	kg
5014	150.5	2.7	123.5	2.6
5024	175.5	3.5	148.5	3.4
5034	200.5	4.2	173.5	4.1

Nota:
il condensatore sarà fornito a corredo

Note:
the capacitor will be supplied separately

Anmerkung:
Der Kondensator wird separat geliefert

1 ~

SMM56.. - B14 - TEFC / TENV

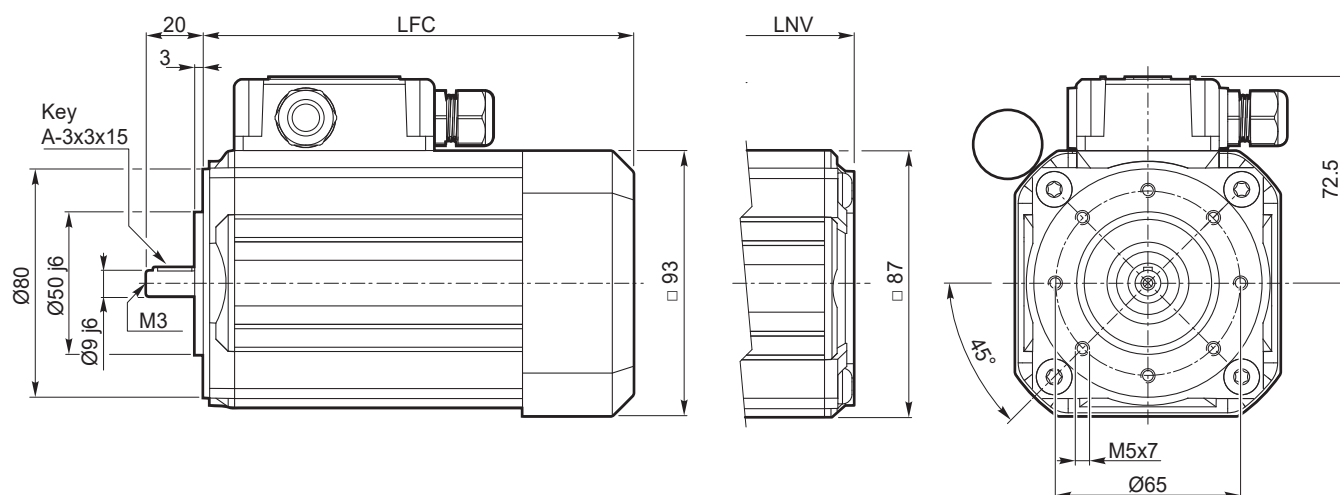

SMM	... TEFC		... TENV	
	LFC	kg	LNV	kg
5624	151	3.3	127	3.2
5634	171	3.9	147	3.8
5644	206	5.0	182	4.9

1~

SMM63.. - B14 - TEFC / TENV

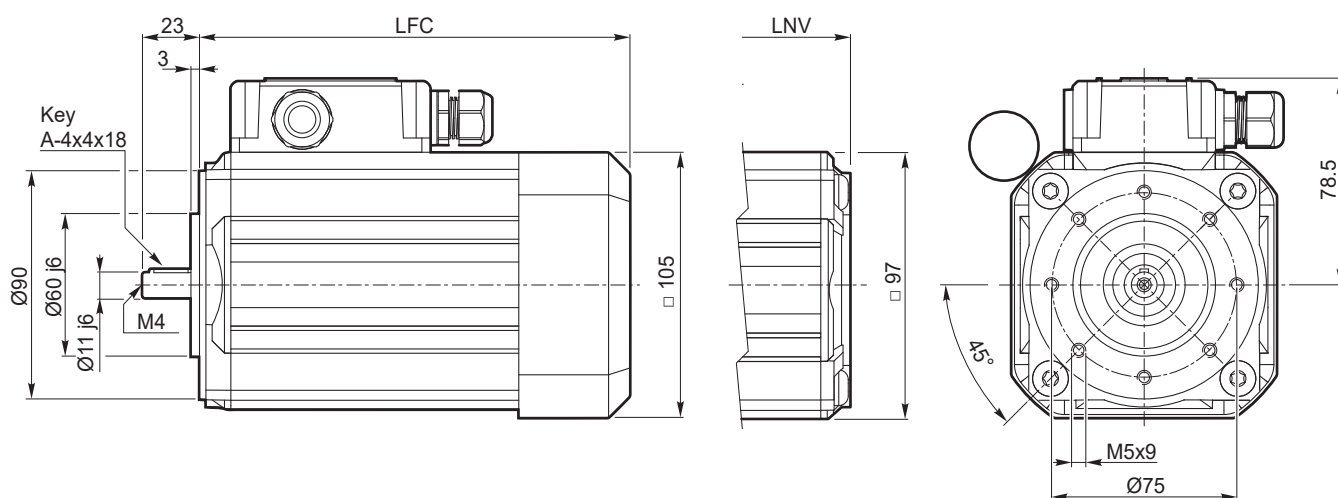

SMM	... TEFC		... TENV	
	LFC	Kg	LNV	Kg
6324	180.5	5.1	153.5	5.0
6334	205.5	6.2	178.5	6.1

1~

SMM71.. - B14 - TEFC / TENV

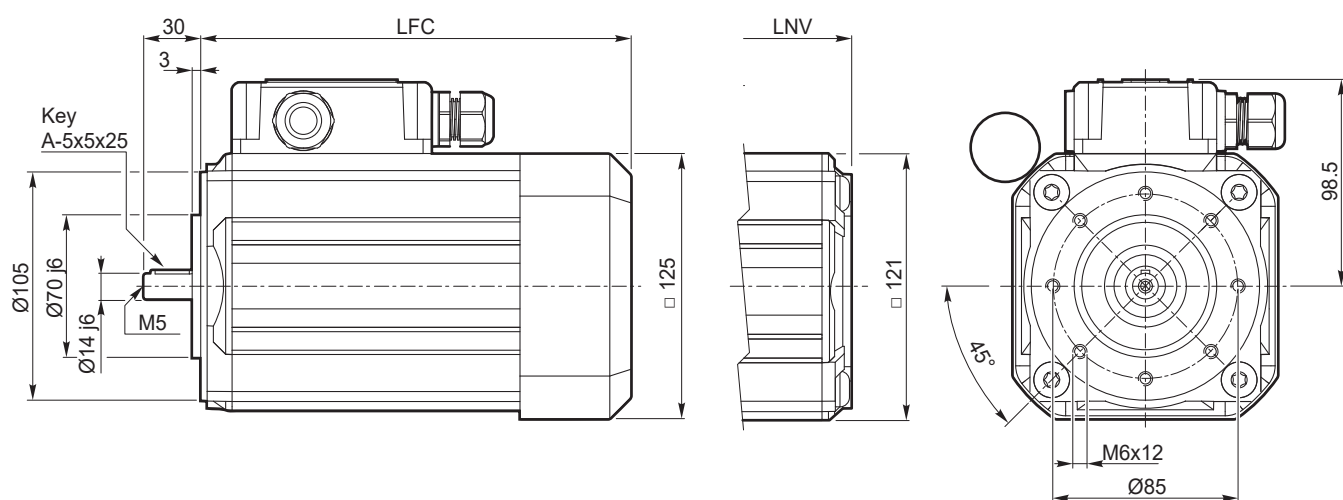

SMM	... TEFC		... TENV	
	LFC	Kg	LNV	Kg
7124	189	7.3	160.5	7.1
7134	214	9.2	185.5	9.0

1 ~

SMM80.. - B14 - TEFC / TENV

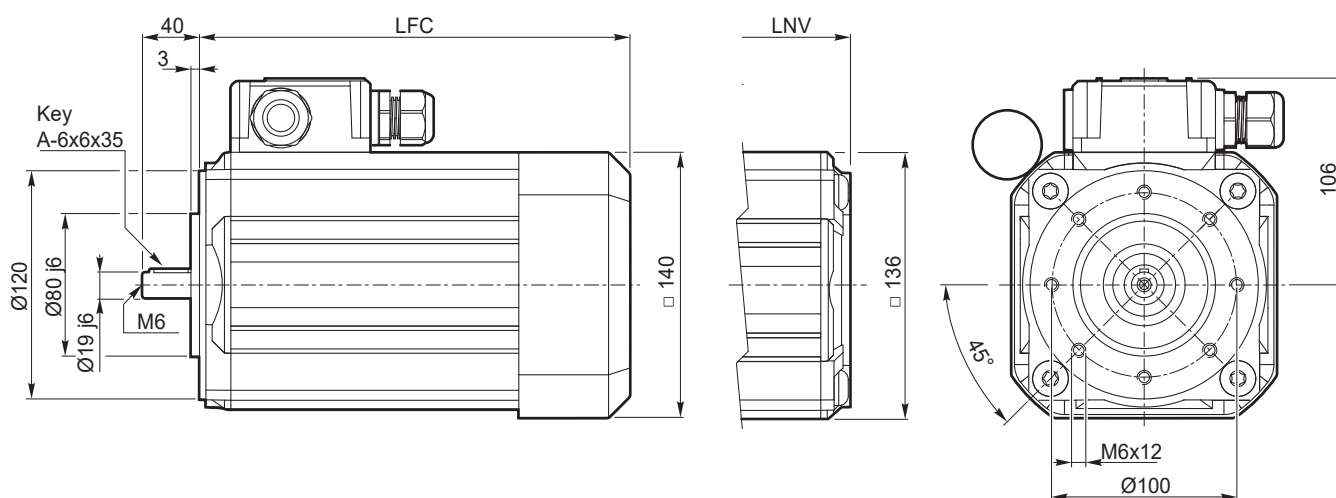

SMM	... TEFC		... TENV	
	LFC	Kg	LNV	Kg
8024	233	11.8	196	11.5

Cava esagonale

Hexagonal socket

Innensechskant

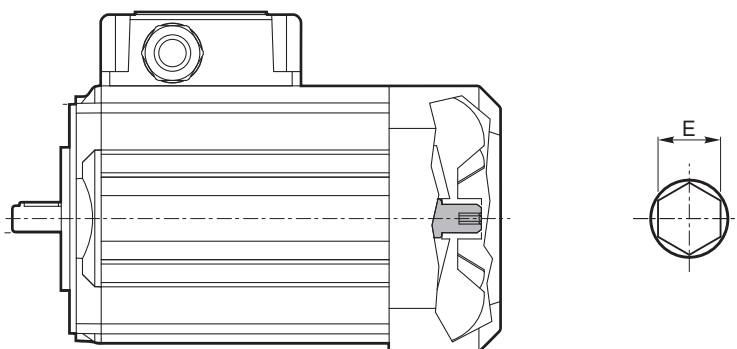

Esagono / Hexagon / Sechskant

SM..	E
50	4
56	
63	
71	6
80	
90	

Nota:

Installare a monte dell'alimentazione un dispositivo che assicuri la disconnessione della rete omnipolare, durante le operazioni di rotazione manuale è obbligatorio l'utilizzo di tale sezionatore.

Il quadro elettrico del motore deve essere lucchettabile al fine di evitare il riarmo non previsto alla rete elettrica.

E' severamente vietata la messa in servizio del motore elettrico senza coprивentola opportunamente montata.

Note:

An omnipolar cut-off device must be fitted upstream of the power supply; the use of this device is mandatory during manual rotation operations.

The switchgear for the motor must be padlockable in order to prevent the power supply from being accidentally reset. It is strictly prohibited to put the electric motor into service if the fan cover is not fitted.

Anmerkung:

Vor der Stromversorgung muss eine allpolige Trennvorrichtung anbebracht werden; Die Verwendung dieses Geräts ist bei manuellen Drehvorgängen obligatorisch.

Das Schaltgerät für den Motor muss abschließbar sein, um ein unbeabsichtigtes Wiedereinschalten der Stromversorgung zu verhindern.

Es ist strengstens verboten, den Elektromotor ohne montierte Lüfterhaube in Betrieb zu nehmen.

Motori elettrici CA - SMT BR
autofrenanti

Caratteristiche tecniche

AC Electric motors - SMT BR
with brake

Technical characteristics

AC Motoren - SMT BR
selbstbremsend

Technische Merkmale

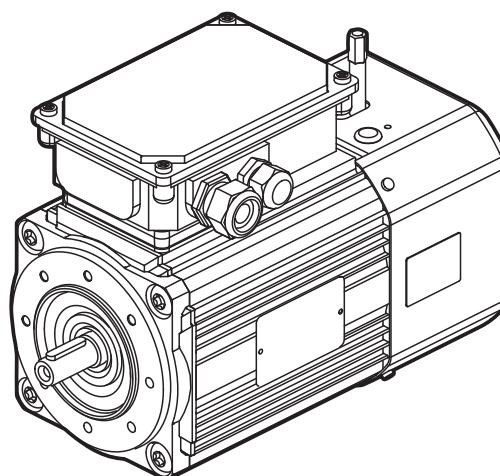
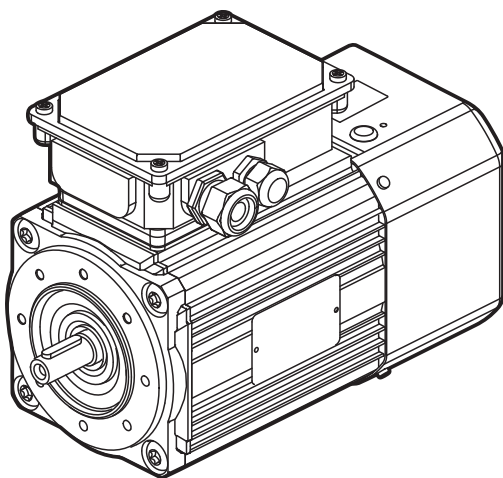

SMT..TEFC BR

SMT..TEFC BRL

I motori autofrenanti delle serie SMT..BR hanno le seguenti caratteristiche principali:

- Costruzione compatta
- Motorizzazioni in corrente alternata trifase
- Carcasa estrusa in alluminio anodizzato nero
- Motore elettrico CA con grado di protezione IP66 (freno IP66 e IP65)
- Rumorosità e vibrazioni contenute
- Isolamento termico di classe F
- Flangia motore IEC B14
- Temperatura ambiente: 0°C / + 40°C (Per utilizzo a temperature diverse contattare il ns. servizio tecnico)
- Disponibili nella versione ventilata TEFC (servizio S1)
- Protezioni termiche PTO 150°C
- Adatti al funzionamento con alimentazione da inverter (Richiedere opzione freno con alimentazione separata)
- SMT80 e SMT90 conformi alla classe di rendimento IE3.
- Cava esagonale su albero motore lato NDE.
- La tolleranza di tensione è $\pm 10\%$ per tutti i motori
- Il freno è a corrente continua

SMT..BR braked motor range has the following main features:

- *Compact design*
- *AC three phase motors available*
- *Black anodized extruded aluminium housing*
- *AC electric motor in IP66 protection Standard (IP66 and IP65 brake)*
- *Low noise and vibrations*
- *Class F insulation Standard*
- *Motor flange IEC B14*
- *Ambient temperature: 0°C / +40°C (For different temperatures contact Transtecno Technical Dept)*
- *Fan cooled TEFC (duty S1) available*
- *PTO 150°C thermal protection*
- *Suitable to be driven by inverter (Request brake option with separate power supply)*
- *SMT80 and SMT90 in compliance to the Standard efficiency class IE3*
- *Motor shaft hexagon socket on the NDE side*
- *The voltage tolerance is $\pm 10\%$ for all motors*
- *The brake is DC*

Die selbstbremsenden Motoren der Serien SMT..BR haben die folgenden Hauptmerkmale:

- kompakte Bauweise
- dreiphasige Wechselstrommotoren
- schwarz eloxiertes, stranggepresstes Aluminiumgehäuse
- AC-Elektromotor mit Schutzart IP66 (Bremse IP66 und IP65)
- geräusch- und vibrationsarm
- Wärmedämmung der Klasse F
- Motorflansch IEC B14
- Umgebungstemperatur: 0°C / + 40°C (Für den Einsatz bei anderen Temperaturen kontaktieren Sie bitte unseren technischen Service)
- erhältlich in der belüfteten Version TEFC (Service S1)
- thermische Schutzvorrichtungen PTO 150°C
- geeignet für den Betrieb mit Umrichterspeisung (Bremsenoption mit separater Speisung anfordern)
- SMT80 und SMT90 entsprechen der Effizienzklasse IE3.
- Sechskantaussparung auf der Motorwelle auf der NDE-Seite.
- die Spannungstoleranz beträgt $\pm 10\%$ für alle Motoren
- die Bremse ist DC

Motori elettrici CA - SMT BR

AC Electric motors - SMT BR

AC Motoren - SMT BR

autofrenanti

with brake

selbstbremsend

Dati tecnici

Technical data

Technische Daten

SMT.BR Motori trifase autofrenanti / *Three phase motors with brake / selbstbremsende Drehstrommotoren*

(230-400 V / 50 Hz) poli / poles / polig **4**

Tipo Type Typ	P _n [kW]	M _n [Nm]	n _n [min ⁻¹]	I _n (400V) [A]	η %	cosφ	M _s /M _n	I _s /I _n	M _k /M _n	PTO	S TEFC	IP Motore Motor Motoren	M _b [Nm]	IP Freno Brake selbstbr.
SMT6324B14.BR(L)	0.18	1.26	1360	0.69	57.0	0.66	2.50	2.90	2.50	PTO 150°	S3 75%	66	4	66
SMT6334B14.BR(L)	0.25	1.74	1375	0.94	62.0	0.64	2.80	3.00	2.80				4	66
SMT7124B14.BR(L)	0.37	2.52	1400	1.10	67.9	0.72	2.75	4.20	2.75				7.5	65
SMT7134B14.BR(L)	0.55	3.76	1395	1.55	70.2	0.73	2.90	4.40	2.90				7.5	65
IE3	SMT8024B14IE3.BR(L)	0.75	4.96	1440	1.94	82.5	0.68	3.6	6.00	3.70	S1	66	15	65
	SMT8034B14IE3.BR(L)	1.1	7.25	1450	2.91	84.1	0.65	4.0	6.80	4.40			15	65
	SMT9024B14IE3.BR(L)	1.5	10.0	1430	3.48	85.3	0.73	3.2	6.30	3.50			20	66
	SMT9034B14IE3.BR(L)	2.2	14.9	1410	4.68	86.7	0.79	3.0	6.20	3.30			30	65

Per dimensioni e ulteriori dati consultare la documentazione disponibile sul sito www.transtecno.com

For dimensions and further data, please see the documentation available on the website www.transtecno.com

Abmessungen und weitere Daten entnehmen Sie bitte der Dokumentation auf der Website www.transtecno.com

3~

SMT63.. - B14 - TEFC - BR (L)

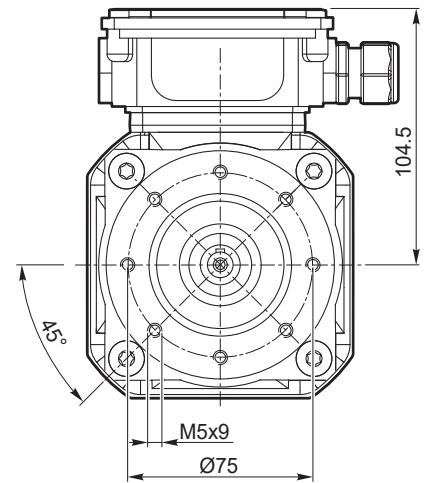
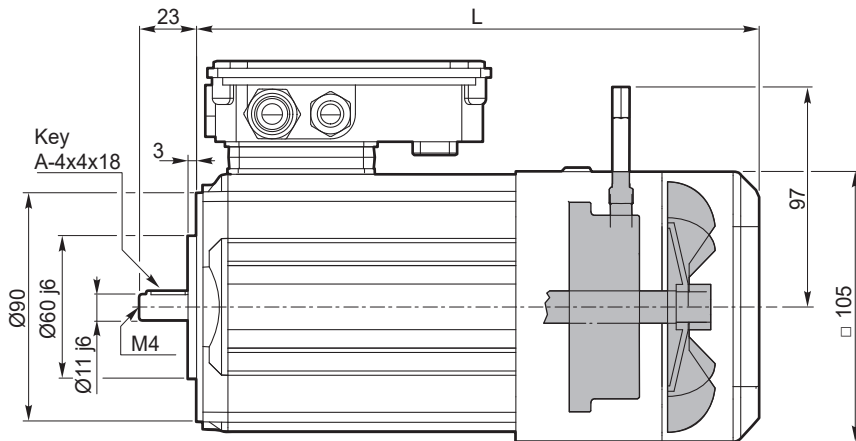

Nota:

La leva di sblocco è una opzione che va specificata in fase di ordine.

Note:

The release lever is an option that must be requested when ordering.

Anmerkung:

Der Entriegelungshebel ist eine Option, die in der Bestellphase angefragt werden soll.

SMT..BR	... TEFC	
	L	Kg
6324	211	5.8
6334	226	6.5

3~

SMT71.. - B14 - TEFC - BR (L)

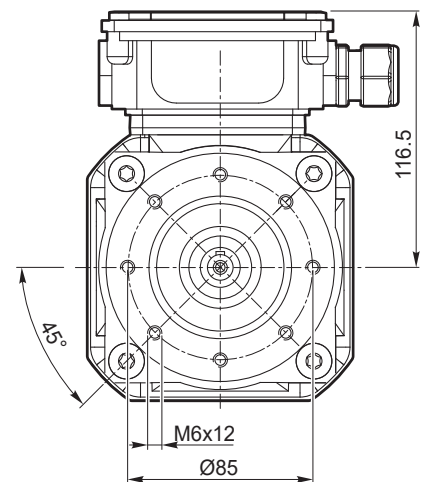
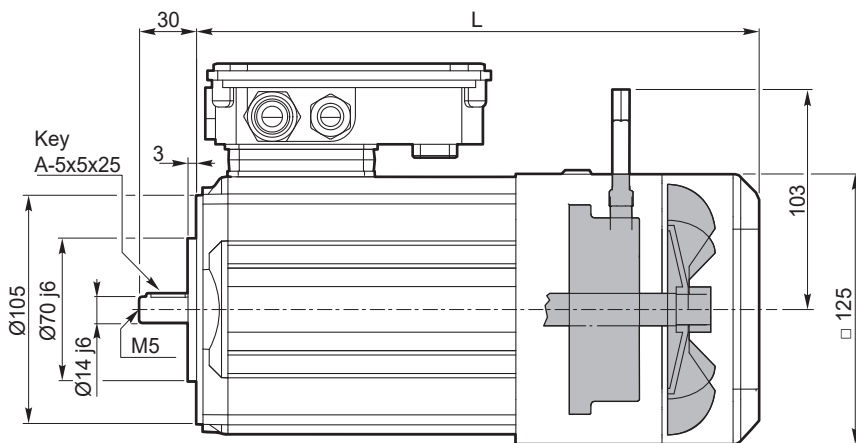

Nota:

La leva di sblocco è una opzione che va specificata in fase di ordine.

Note:

The release lever is an option that must be requested when ordering.

Anmerkung:

Der Entriegelungshebel ist eine Option, die in der Bestellphase angefragt werden soll.

SMT..BR	... TEFC	
	L	Kg
7124	221	7.8
7134	236	8.9

3~

SMT80.. - B14 - TEFC - BR (L)

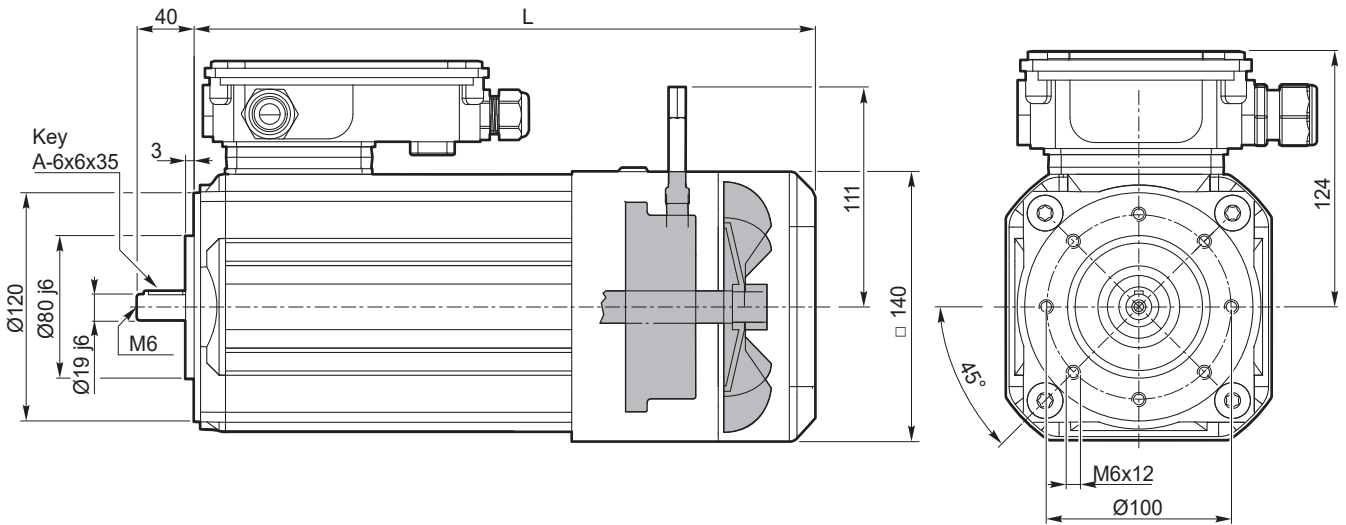

Nota:

La leva di sblocco è una opzione che va specificata in fase di ordine.

Note:

The release lever is an option that must be requested when ordering.

Anmerkung:

Der Entriegelungshebel ist eine Option, die in der Bestellphase angefragt werden soll.

SMT..BR	... TEFC	
	L	Kg
8024	279.5	13.6
8034	329.5	17.9

3~

SMT90.. - B14 - TEFC - BR (L)

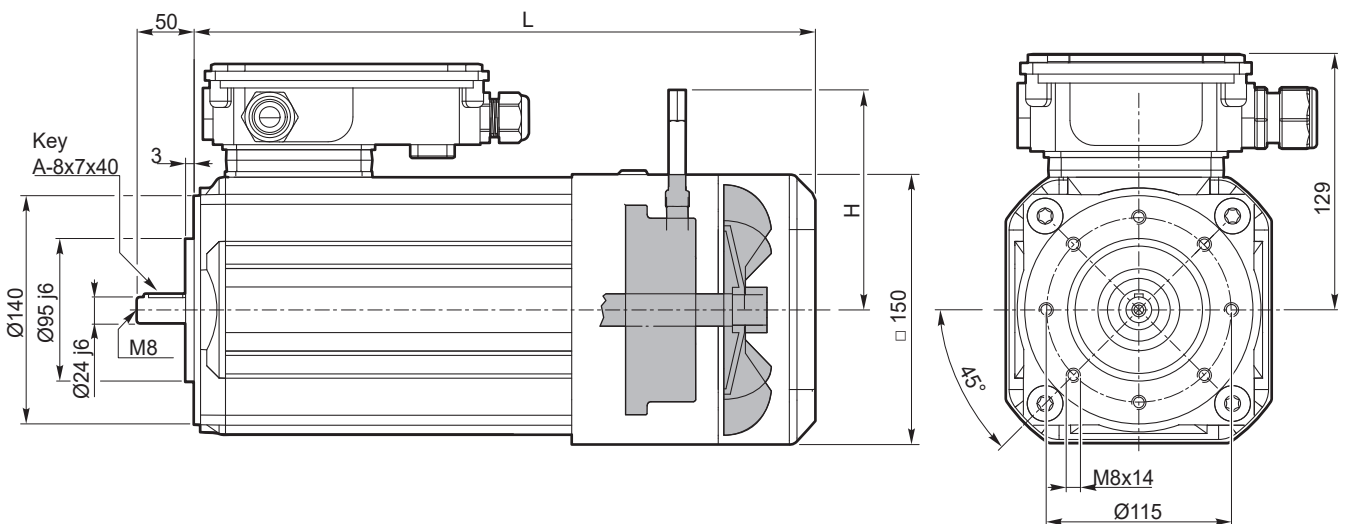

Nota:

La leva di sblocco è una opzione che va specificata in fase di ordine.

Note:

The release lever is an option that must be requested when ordering.

Anmerkung:

Der Entriegelungshebel ist eine Option, die in der Bestellphase angefragt werden soll.

SMT..BR	... TEFC	
	L	Kg
9024	343	20.6
9034	373	24.7

SMT..BRL	... TEFC		
	L	H	Kg
9024	343	111.5	20.9
9034	367	138	25

Motori elettrici CA - SMT SV

servoventilati

Caratteristiche tecniche

AC Electric motors - SMT SV

with forced-ventilation

Technical characteristics

AC Motoren - SMT SV

selbstbremsend Drehstrommotoren

Technische Merkmale

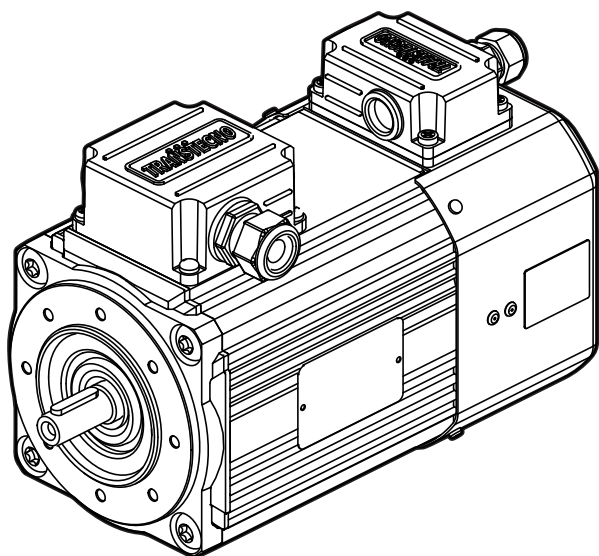

SMT..SV



I motori delle serie SMT..SV hanno le seguenti caratteristiche principali:

- Costruzione compatta
- Motorizzazioni in corrente alternata trifase
- Carcassa estrusa in alluminio anodizzato nero
- Motore elettrico CA con grado di protezione IP 66 (solo motore - servoventola con grado di protezione IP44)
- Rumorosità e vibrazioni contenute
- Isolamento termico di classe F
- Flangia motore IEC B14
- Temperatura ambiente: 0°C / + 40°C (Per utilizzo a temperature diverse contattare il ns. servizio tecnico)
- Protezioni termiche PTO 150°C
- Adatti al funzionamento con alimentazione da inverter
- SMT80 e SMT90 conformi alla classe di rendimento IE3.
- La tolleranza di tensione è $\pm 10\%$ per tutti i motori

SMT..SV motor range has the following main features:

- *Compact design*
- *AC three phase motors available*
- *Black anodized extruded aluminium housing*
- *AC Electric motors with IP66 Protection standard (only motor - Servo fan with IP44 protection Standard)*
- *Low noise and vibrations*
- *Class F insulation Standard*
- *Motor flange IEC B14*
- *Ambient temperature: 0°C / +40°C (For different temperatures contact Transtecno Technical Dept)*
- *PTO 150°C thermal protection*
- *Suitable to be driven by inverter*
- *SMT80 and SMT90 in compliance to the Standard efficiency class IE3*
- *The voltage tolerance is $\pm 10\%$ for all motors*

Die Motoren der Serien SMT..SV haben die folgenden Hauptmerkmale:

- kompakte Bauweise
- dreiphasige Wechselstrommotoren
- schwarz eloxiertes, stranggepresstes Aluminiumgehäuse
- AC-Elektromotor mit Schutzart IP66 (nur Motor - Servolüfter mit Schutzart IP44)
- geräusch- und vibrationsarm
- Wärmedämmung der Klasse F
- Motorflansch IEC B14
- Umgebungstemperatur: 0°C / + 40°C (Für den Einsatz bei anderen Temperaturen kontaktieren Sie bitte unseren technischen Service)
- thermische Schutzvorrichtungen PTO 150°C
- geeignet für den Betrieb mit Wechselrichterstromversorgung
- SMT80 und SMT90 entsprechen der Effizienzklasse IE3.
- die Spannungstoleranz beträgt $\pm 10\%$ für alle Motoren

Motori elettrici CA - SMT SV

AC Electric motors - SMT VS

AC Motoren - SMT SV

servoventilati

with forced-ventilation

selbstbremsend Drehstrommotoren

Dati tecnici

Technical data

Technische Daten

SMT..SV Motori trifase servoventilati / three phase motors with forced-ventilation / servobelüftete Drehstrommotoren

(230-400 V / 50 Hz) poli / poles / polig **4**

Tipo Type Typ	P _n [kW]	M _n [Nm]	n _n [min ⁻¹]	I _n (400V) [A]	η %	cosφ	M _s /M _n	I _s /I _n	M _k /M _n	PTO	S SV	IP Motore Motor Motoren	IP Servoventola Forced vent. Drehstrom.	P _{sf} [W]
SMT6324B14.SV	0.18	1.26	1360	0.69	57.0	0.66	2.50	2.90	2.50	PTO 150°	S3 75%	66	44	11-9
SMT6334B14.SV	0.25	1.74	1375	0.94	62.0	0.64	2.80	3.00	2.80				44	11-9
SMT6344B14.SV	0.37	2.60	1360	1.24	65.3	0.66	2.70	3.00	2.70				44	11-9
SMT7124B14.SV	0.37	2.52	1400	1.10	67.9	0.72	2.75	4.20	2.75				44	14-16
SMT7134B14.SV	0.55	3.76	1395	1.55	70.2	0.73	2.90	4.40	2.90				44	14-16
SMT7144B14.SV	0.75	5.09	1405	2.00	74.0	0.73	2.90	5.00	2.90				44	14-16
IE3	SMT8024B14IE3.SV	0.75	4.96	1440	1.94	82.5	3.6	6.00	3.70		S1	44	14-16	
	SMT8034B14IE3.SV	1.1	7.25	1450	2.91	84.1	4.0	6.80	4.40			44	14-16	
	SMT9024B14IE3.SV	1.5	10.0	1430	3.48	85.3	3.2	6.30	3.50			44	30-26	
	SMT9034B14IE3.SV	2.2	14.9	1410	4.68	86.7	0.79	3.0	6.20			3.30	44	30-26

Alimentazione della servoventola: 200-240 Vac / 50-60 Hz
Forced ventilation supply voltage: 200-240 Vac / 50-60 Hz
Stromversorgung des Servolüfters: 200-240 Vac / 50-60 Hz

Mot

Per dimensioni e ulteriori dati consultare la documentazione disponibile sul sito www.transtecno.com
For dimensions and further data, please see the documentation available on the website www.transtecno.com
Abmessungen und weitere Daten entnehmen Sie bitte der Dokumentation auf der Website www.transtecno.com

3~

SMT63.. - B14 - SV

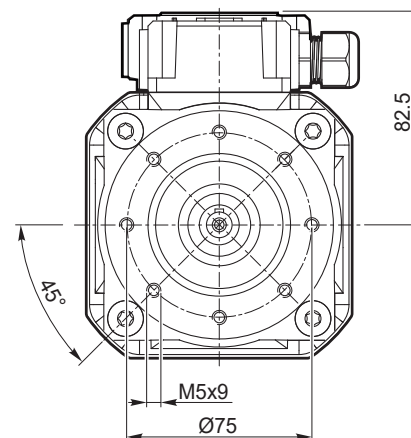
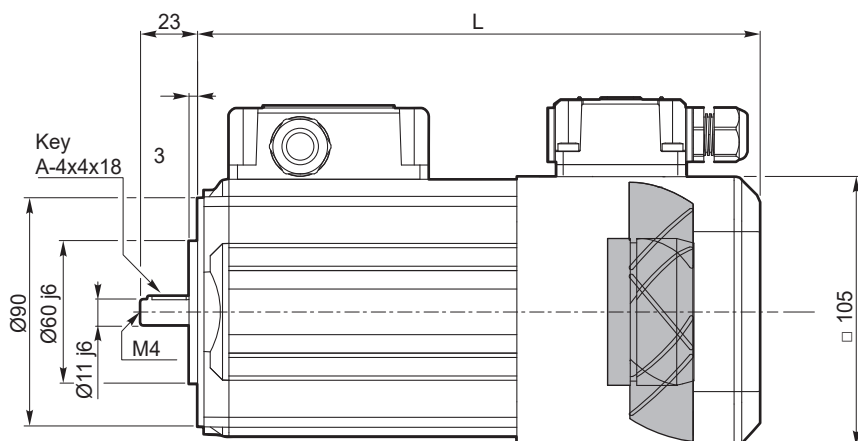

SMT	... SV	
	L	Kg
6324	210	5.0
6334	225	5.7
6344	250	6.8

3~

SMT71.. - B14 - SV

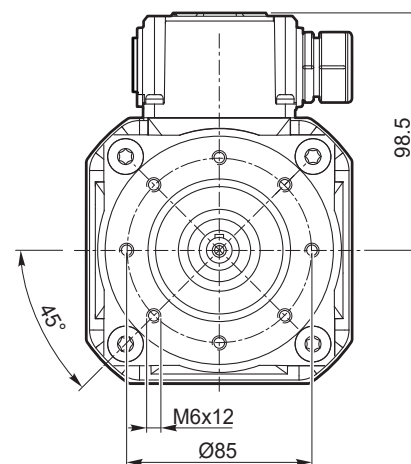
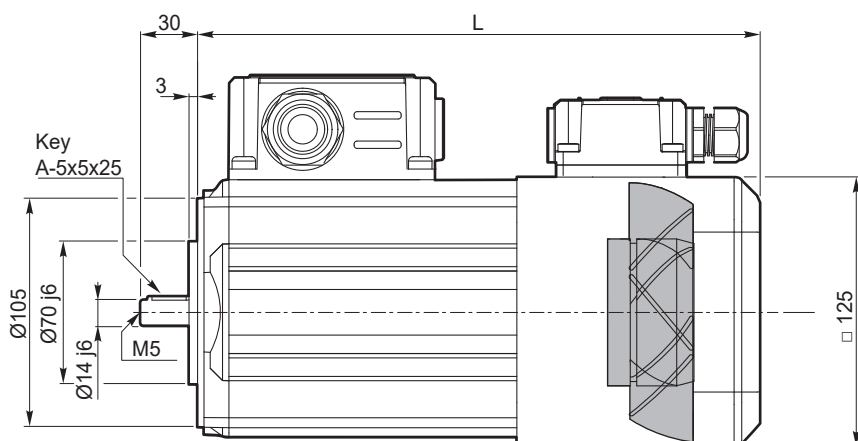

SMT	... SV	
	L	Kg
7124	219	7.5
7134	234	8.5
7144	259	10.2

3~

SMT80.. - B14 - SV

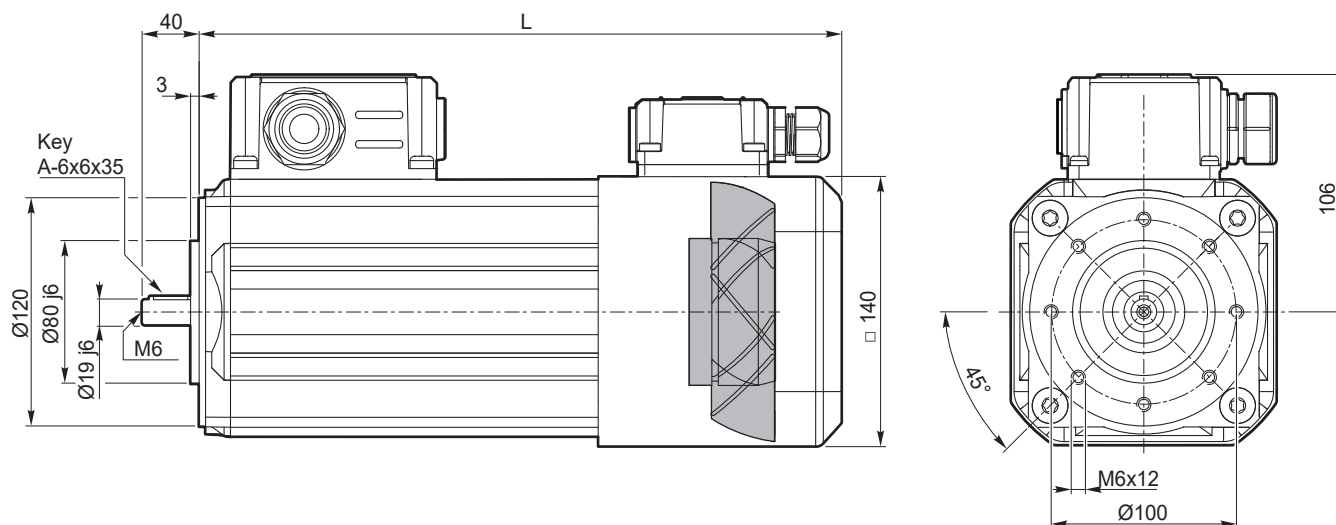

SMT	... SV	
	L	kg
8024	278	12.7
8034	328	17

3~

SMT90.. - B14 - SV

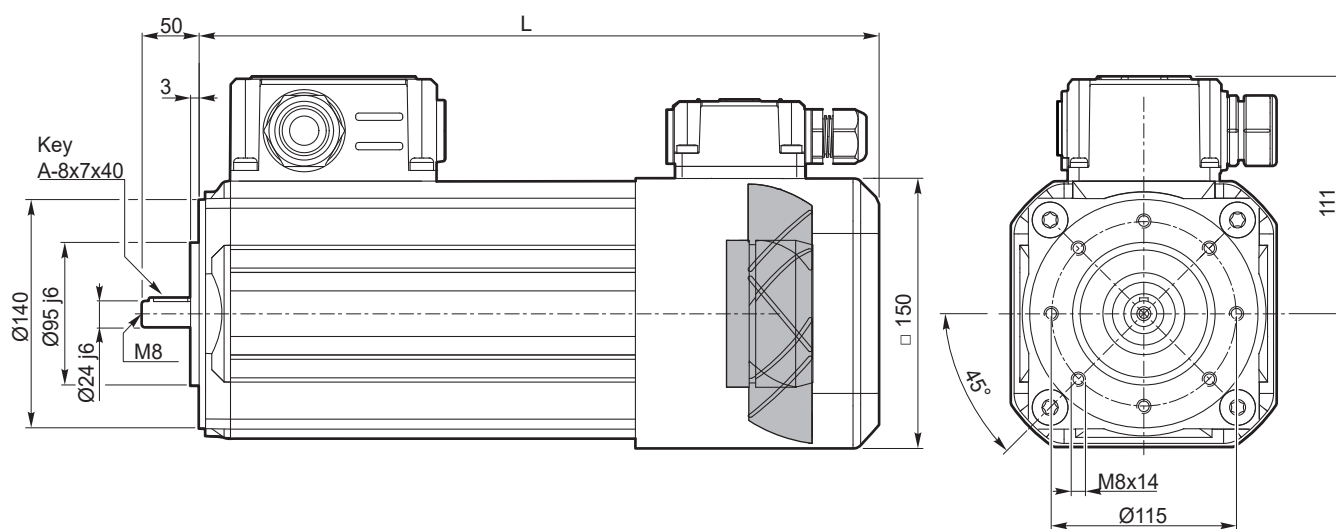

SMT	... SV	
	L	kg
9024	341	19.3
9034	371	22.6

Caratteristiche tecniche

Technical characteristics

Technische Merkmale

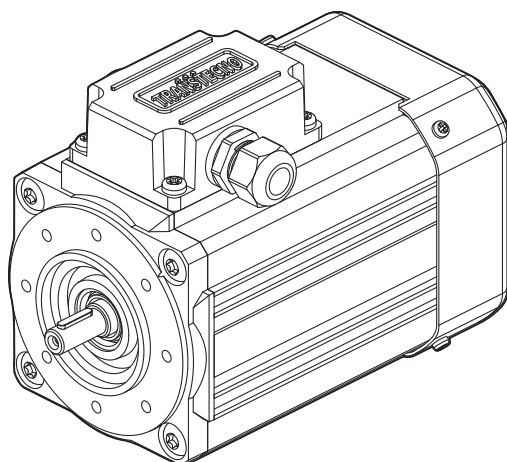

File E511911

SM .. UL/CSA

I motori certificati UL/CSA delle serie SMT ed SMM hanno le seguenti caratteristiche principali:

- Costruzione compatta
- Motorizzazioni in corrente alternata monofase e trifase
- Carcassa estrusa in alluminio anodizzato nero
- Motore elettrico CA con grado di protezione IP66 (escluso condensatore)
- Rumorosità e vibrazioni contenute
- Isolamento termico di classe F
- Flangia motore IECB14
- Temperatura ambiente: -20°C/+40°C
- Disponibili nella versione ventilata TEFC (servizio S1).
- Protezione termica PTO 150°C
- Motori trifase SMT dotati di separatori di fase
- Cava esagonale su albero motore lato NDE
- Condensatore di marcia per motori monofase SMM
- La tolleranza di tensione è $\pm 10\%$
- Standard applicati:
UL1004-1: Rotating Electrical Machines General Requirements
CSA:100-14: Motors and Generators

SMT and SMM motor range with UL/CSA Certification has the following main features:

- *Compact design*
- *AC single phase and three phase motors available*
- *Black anodized extruded aluminium housing*
- *AC electric motor in IP66 protection Standard (except capacitor)*
- *Low noise and vibrations*
- *Class F insulation Standard*
- *Motor flange IEC B14*
- *Ambient temperature: -20°C / +40°C*
- *Fan cooled TEFC (duty S1)*
- *PTO 150° C thermal protection*
- *Three phase motors SMT equipped with phase separators.*
- *Motor shaft hexagon socket on the NDE side.*
- *Running capacitor for single phase motors SMM.*
- *Voltage tolerance $\pm 10\%$*
- *Standards applied:*
UL1004-1: Rotating Electrical Machines- General Requirements
CSA:100-14: Motors and Generators

Die UL/CSA-zertifizierten Motoren der Serien SMT und SMM haben die folgenden Hauptmerkmale:

- kompakte Bauweise
- einphasige und dreiphasige Wechselstrommotoren
- schwarz eloxiertes, stranggepresstes Aluminiumgehäuse
- AC-Elektromotor mit Schutzart IP66 (außer Kondensator)
- geräusch- und vibrationsarm
- Wärmedämmung der Klasse F
- Motorflansch IECB14
- Umgebungstemperatur: 20°C/+40°C
- erhältlich in der belüfteten Version TEFC (Service S1).
- thermische Schutzvorrichtungen PTO 150°C
- dreiphasige SMT-Motoren mit Phasentrennern
- Sechskantaussparung auf der Motorwelle auf der NDE-Seite
- Betriebskondensator für einphasige SMM-Motoren
- die Spannungstoleranz beträgt $\pm 10\%$
- angewandte Normen: UL1004-1: Rotating Electrical Machines General Requirements
CSA:100-14: Motors and Generators

Dati tecnici

Technical data

Technische Daten

SMT Motori trifase / Three phase motors / Drehstrommotoren

(230-400 V / 50 Hz) poli / poles / polig **4**

(460 V / 60 Hz) poli / poles / polig **4**

Tipo Type Typ	P _n [kW]	M _n [Nm]	n _n [min ⁻¹]	V - f [V - Hz]	I _n (400-460 V) [A]	η %	cosφ	M _s /M _n	I _s /I _n	M _k /M _n	PTO	S TEFC
5624	0.09	0.63	1365	400 - 50	0.45	47.3	0.61	2.50	2.40	2.70	PTO 150°	S1
	0.11		1660	460 - 60		50.3		2.60	2.60			
5634	0.12	0.88	1300	400 - 50	0.45	52.0	0.74	1.90	2.40	1.90		
	0.14	0.83	1600	460 - 60	0.42	59.0	0.71	2.10	2.70	2.10		
6324	0.18	1.26	1360	400 - 50	0.69	57.0	0.66	2.50	2.90	2.50		
	0.22	1.27	1650	460 - 60		59.7	0.67		3.00			
6334	0.25	1.74	1375	400 - 50	0.94	62.0	0.64	2.80	3.00	2.80		
	0.28	1.59	1690	460 - 60		61.3	0.61	3.00	3.20	3.00		
7124	0.37	2.52	1400	400 - 50	1.09	68.0	0.72	2.75	4.20	2.75		
	0.42	2.35	1700	460 - 60		68.1	0.71	2.90	4.50	2.90		
7134	0.55	3.76	1395	400 - 50	1.55	70.2	0.73	2.90	4.40	2.90		
	0.66	3.71	1700	460 - 60		73.2			4.80	2.80		
8024	0.75	4.96	1440	400 - 50	1.97	82.0	0.67	3.60	6.00	3.70		
	0.90	4.93	1740	460 - 60		84.3	0.68	3.40	6.40	3.60		
8034	1.10	7.25	1450	400 - 50	2.92	83.6	0.65	4.0	6.80	4.40		
	1.21	6.65	1740	460 - 60		77.6	0.67	4.4	7.00	4.50		
9024	1.50	10.0	1430	400 - 50	3.48	85.2	0.73	3.2	6.30	3.50		
	1.80	9.88	1740	460 - 60		85.4	0.76	3.4	6.50	3.40		

SMM Motori monofase / Single phase motors / Einphasenmotoren

(115 V / 60 Hz) poli / poles / polig **4**

Tipo Type Typ	P _n [kW]	M _n [Nm]	n _n [min ⁻¹]	V - f [V - Hz]	I _n (115V) [A]	η %	cosφ	M _s /M _n	I _s /I _n	M _k /M _n	Cond./Cap./Kond. [μF]	PTO	S TEFC
5624	0.09	0.52	1665	115 - 60	1.60	50.0	0.98	0.64	1.95	1.51	20	PTO 150°	S1
6324	0.18	1.09	1570	115 - 60	2.70	58.5	0.99	1.0	2.1	1.50	40		
7124	0.37	2.18	1620	115 - 60	4.70	69.8	0.98	0.64	2.3	1.33	60		

Per la simbologia fare riferimento a pag. E3

For symbols please refer to page E3

Symbole siehe Seite E3

Per dimensioni e ulteriori dati consultare la documentazione disponibile sul sito www.transtecno.com

For dimensions and further data, please see the documentation available on the website www.transtecno.com

Abmessungen und weitere Daten entnehmen Sie bitte der Dokumentation auf der Website www.transtecno.com

3~

SMT56.. - B14 - TEFC

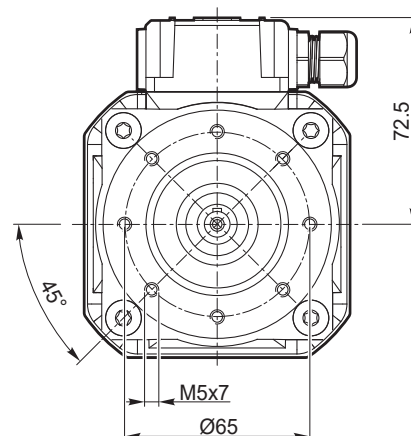
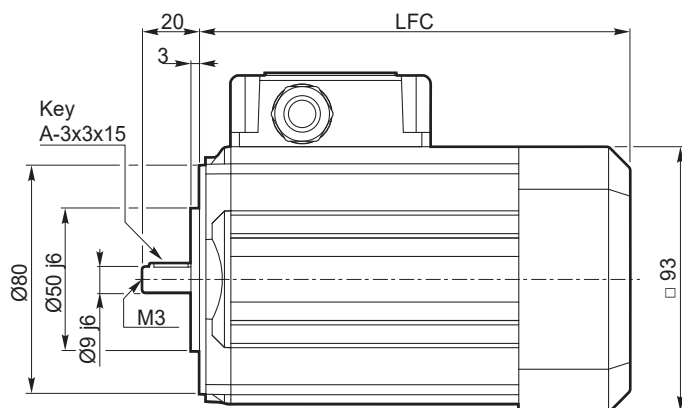

SMT	... TEFC	
	LFC	Kg
5624	186	3.1
5634	186	3.5

3~

SMT63.. - B14 - TEFC

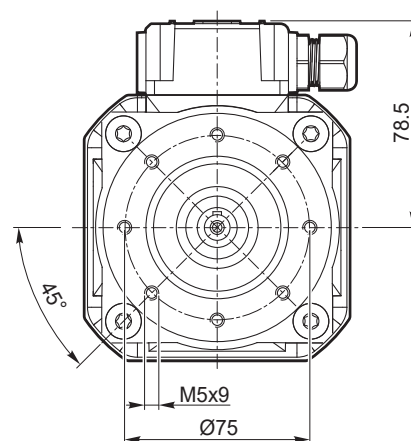
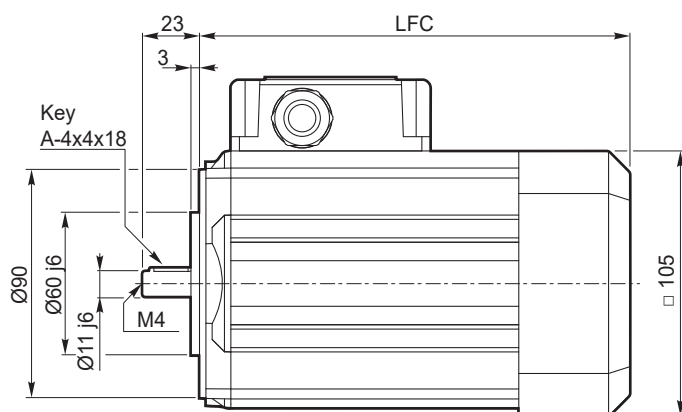

SMT	... TEFC	
	LFC	Kg
6324	205.5	4.7
6334	205.5	5.4

3~

SMT71.. - B14 - TEFC

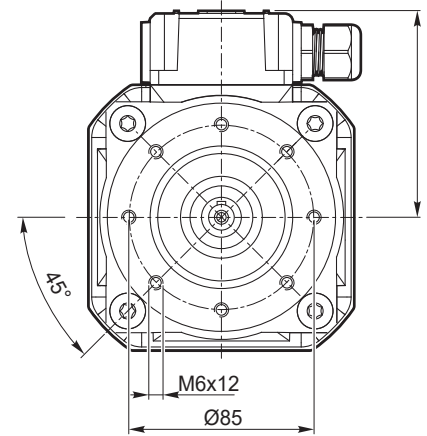
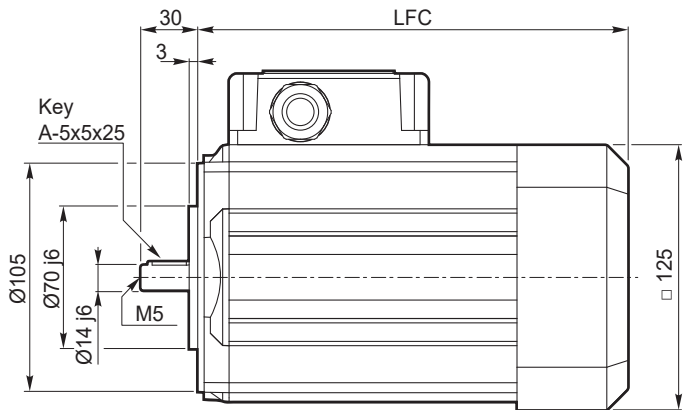

SMT	... TEFC	
	LFC	Kg
7124	214	7.0
7134	214	8.2

3~

SMT80.. - B14 - TEFC

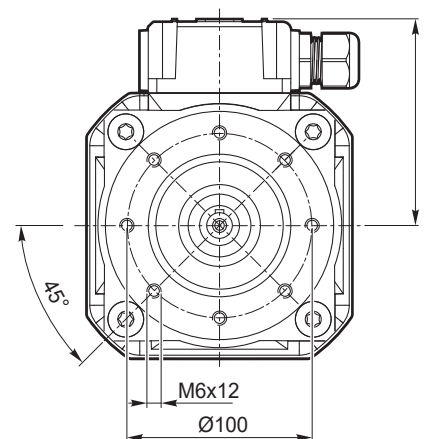
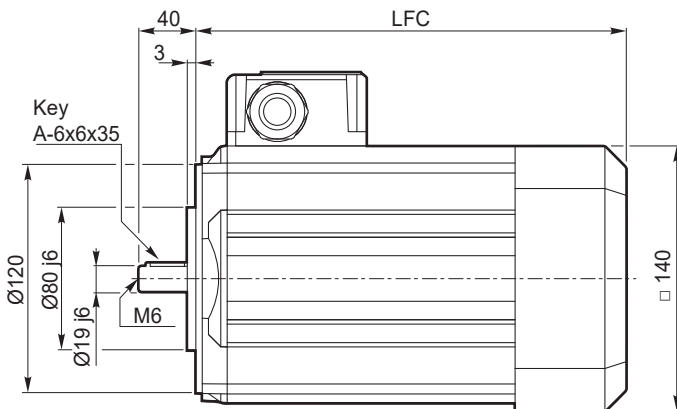

SMT	... TEFC	
	LFC	Kg
8024	283	12.8
8034	309	17.1

3~

SMT90.. - B14 - TEFC

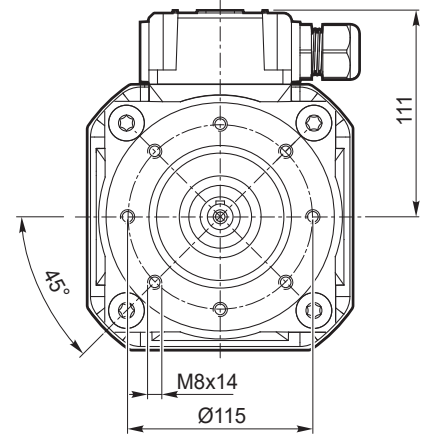
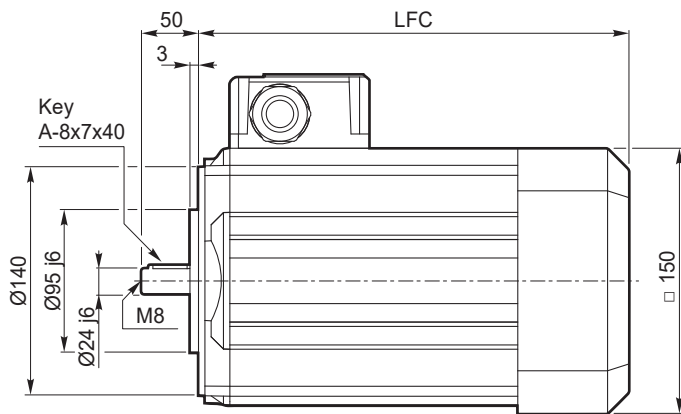

SMT	... TEFC	
	LFC	Kg
9024	313	18.5

1 ~

SMM56.. - B14 - TEFC

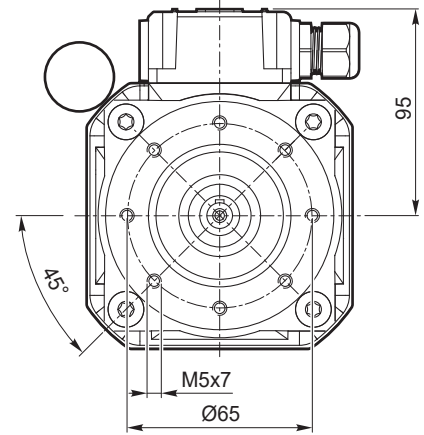
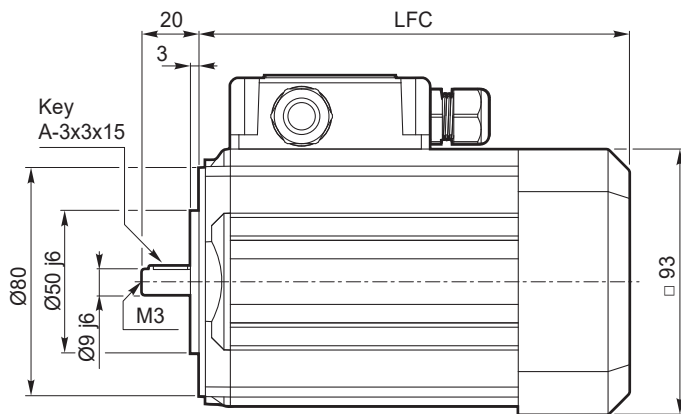

SMM	... TEFC	
	LFC	Kg
5624	186	3.6

1 ~

SMM63.. - B14 - TEFC

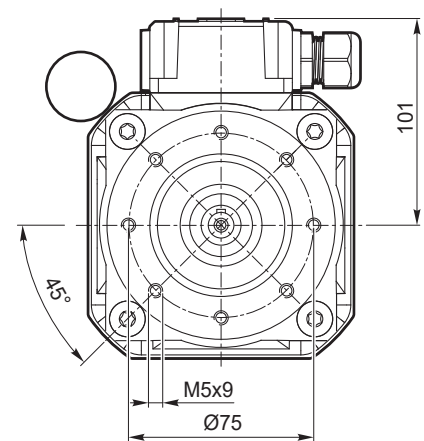
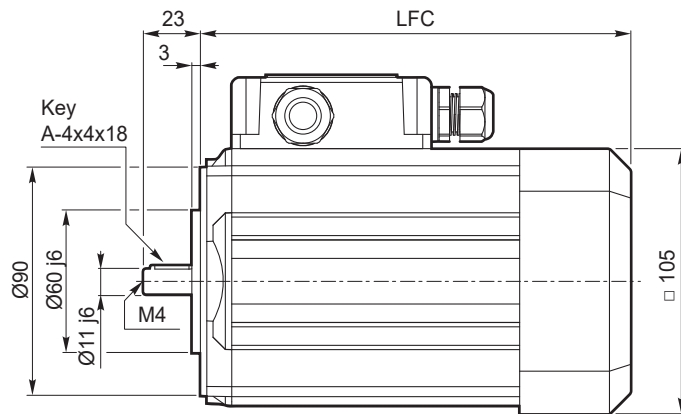

SMM	... TEFC	
	LFC	Kg
6324	205.5	5.5

1 ~

SMM71.. - B14 - TEFC

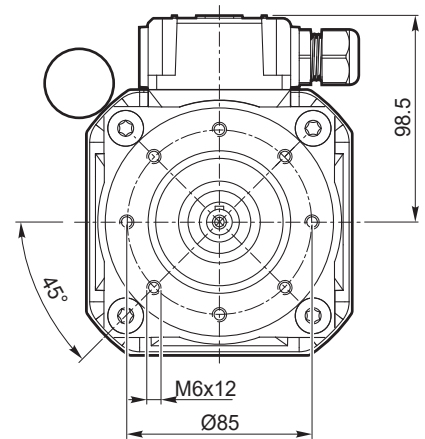
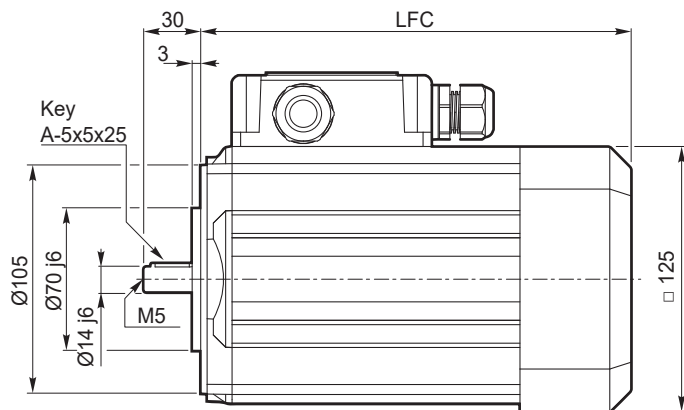

SMM	... TEFC	
	LFC	kg
7124	214	8.0



DRAINTECH SRL HEADQUARTERS

Company subject to the management
and coordination of INTERPUMP GROUP SPA
Via 1° Maggio 3/5
40011 Anzola dell'Emilia (BO) - ITALY
T +39 051 72 74 47
F + 39 051 03 53 028
info@draintech.it
www.draintech.it



member of
TRANSTECNO
group



**HANGZHOU INTERPUMP
POWER TRANSMISSIONS CO LTD**
No.4 Xiuyan Road Fengdu Industry Zone
Pingyao Town Yuhang District
Hangzhou City, Zhejiang Province
311115 – CHINA
T +86 571 86 92 02 60
info-china@transtecno.cn
www.transtecno.cn



**TRANSTECNO IBÉRICA
THE MODULAR GEARMOTOR, S.A.**
Carrer de la Ciència, 45
08840 Viladecans (Barcelona) - SPAIN
T +34 931 598 950
info@transtecno.es
www.transtecno.es



TRANSTECNO B.V.
Siliciumweg 32
3812 SX Amersfoort - NETHERLANDS
T +31(0) 33 45 19 505
info@transtecno.nl
www.transtecno.nl



TRANSTECNO AANDRIJFTECHNIEK B.V.
Siliciumweg 32
3812 SX Amersfoort - NETHERLANDS
T +31 (0) 33 20 4 7 006
info@transtecnoaandrijftechnik.nl
www.transtecnoaandrijftechnik.nl



MA TRANSTECNO S.A.P.I. DE C.V.
Julián Sepúlveda Dávila #107,
Parque Industrial SG
Apodaca, Nuevo León, CP. 66640
MÉXICO
T +52 8113340920
info@transtecno.com.mx
www.transtecno.com.mx



TRANSTECNO USA
8 Creek Parkway,
Boothwyn PA 19061-8136 - UNITED STATES
T + 1 (610) 4970154

TRANSTECNO USA – WEST COAST BRANCH
14561 Fryelands Blvd SE
Monroe, WA 98272 - UNITED STATES
T +1 360-863-1300
usaoffice@transtecno.com
www.transtecno.com



TRANSTECNO CANADA
51 B Caldari Road Unit 10
Vaughan, ON L4K 4G3 - CANADA
T +1 905 761 0762
canadaoffice@transtecno.com
www.transtecno.com



TRANSTECNO INDIA
#6A, Sipcot Industrial complex, Phase-1,Elasagiri Road
Hosur – 635126 Tamilnadu - INDIA
T +91 4344 274434
M +91 81443 88800

TRANSTECNO INDIA – NORTH BRANCH
Plot No: 3 A, Sector 2, IIE, Sidcul, Pantnagar
U.S. Nagar, Uttarakhand – 263153 - INDIA
indiaoffice@transtecno.com
www.transtecno.com



TRANSTECNO BRAZIL
Rua Gilberto de Zorzi, 525 Forqueta - CEP. 95115-730
CX Postal 3544 Caxias do Sul RS – BRAZIL

TRANSTECNO BRAZIL – SÃO PAULO BRANCH
R. Mafalda Barnabe Soliane, 314 – CEP. 13347-610
Indaiatuba, São Paulo – BRAZIL
T +55 19 3437 2520

TRANSTECNO BRAZIL – PORTO ALEGRE BRANCH
Rua Dr. Freire Alemão 155 / 402 - CEP. 90450-060
Auxiliadora Porto Alegre RS - BRAZIL
T +55 51 4042 0916
M +55 51 811 45 962
braziloffice@transtecno.com
www.transtecno.com.br



INTERPUMP ANTRIEBSTECHNIK GMBH
Büro Stuttgart - GERMANY
T +49 (0)171 4781909
germanoffice@transtecno.com
www.transtecno.com



SALES OFFICE OCEANIA
Unit 5, 12 Nyholt Drive, Yatala 4207
Queensland - AUSTRALIA
T +61 07 3800 0103
M +61 04 38060997

UNIT 9 , 94 Boundary Rd, Sunshine West 3020
Victoria - AUSTRALIA
T +61 9312 4722
oceaniaoffice@transtecno.com
www.transtecno.com.au