

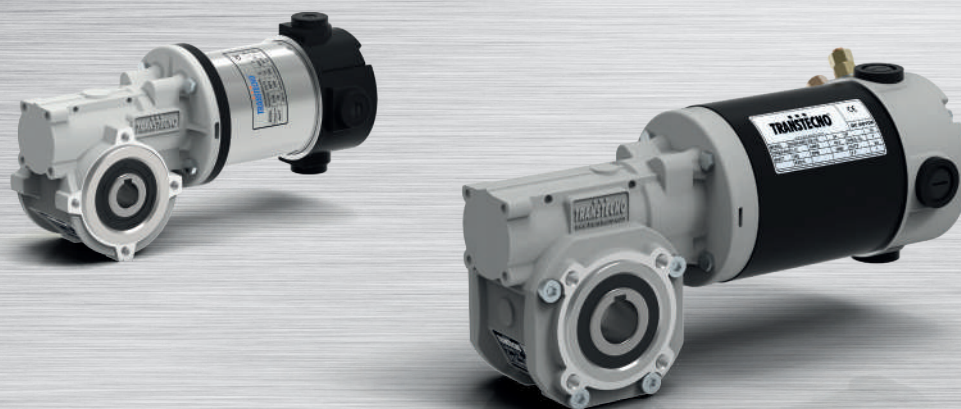

Neodymium

Ferrite

Motoriduttori CC a vite senza fine DC wormgearmotors



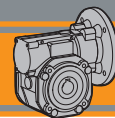

Indice	Index	Pag. Page
Caratteristiche tecniche	<i>Technical features</i>	S2
Designazione	<i>Classification</i>	S2
Sensi di rotazione	<i>Direction of rotation</i>	S2
Simbologia	<i>Symbols</i>	S3
Lubrificazione	<i>Lubrication</i>	S3
Carichi radiali	<i>Radial loads</i>	S3
Dati di dentatura	<i>Toothing data</i>	S4
Rendimento	<i>Efficiency</i>	S4
Motori applicabili	<i>IEC Motor adapters</i>	S5
Dimensioni	<i>Dimensions</i>	S6
Accessori	<i>Accessories</i>	S12
Opzioni	<i>Options</i>	S13

Questa sezione annulla e sostituisce ogni precedente edizione o revisione. Qualora questa sezione non Vi sia giunta in distribuzione controllata, l'aggiornamento dei dati ivi contenuto non è assicurato. **In tal caso la versione più aggiornata è disponibile sul nostro sito internet www.transtecno.com**

This section replaces any previous edition and revision. If you obtained this catalogue other than through controlled distribution channels, the most up to date content is not guaranteed. In this case the latest version is available on our web site www.transtecno.com

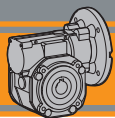

CL Motoriduttori a vite senza fine Wormgearmotors

Caratteristiche tecniche

Technical features

L'elevata modularità contraddistingue i motoriduttori a vite senza fine della serie CL: i diversi kit entrata ed uscita li rendono estremamente versatili.

The high degree of modularity is a design feature of CL wormgearmotors range thanks to a wide selection of input and output kits. Main features of CL range are:

Le caratteristiche principali della serie CL sono:

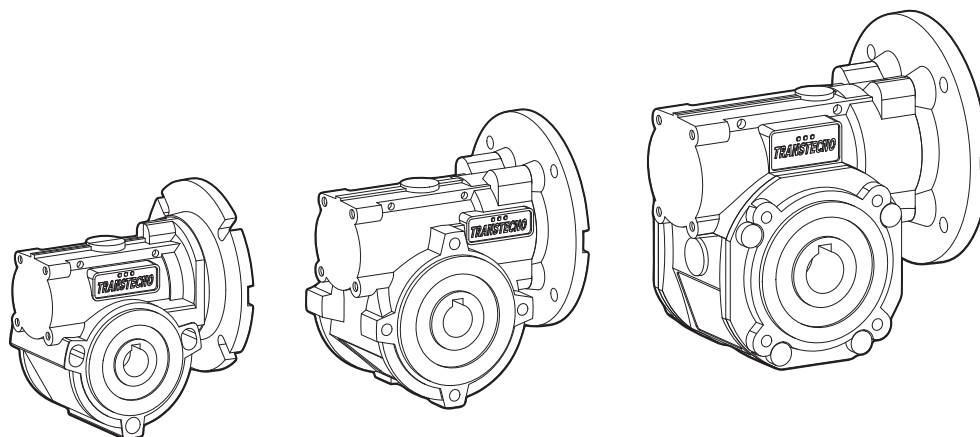

- Carcassa in alluminio
- Lubrificazione permanente con olio sintetico
- Die-cast aluminium housing
- Permanent synthetic oil long life lubrication



Designazione

Classification

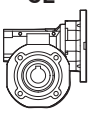
RIDUTTORI A VITE SENZA FINE / WORMGEARBOXES

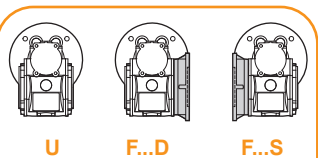
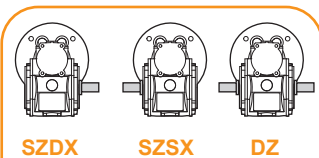
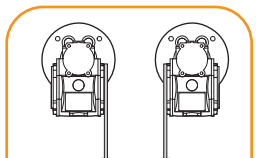
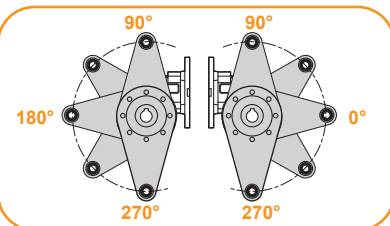
RIDUTTORE / GEARBOX									
CL	030	U	10	63	B14	SZDX	BRSX	90	VS
Tipo Type	Grandezza Size	Versione riduttore Gearbox Version	Rapporto Ratio	IEC	Forma costruttiva Version	Albero di uscita Output shaft	Braccio di reazione Torque arm	Angolo Angle	Opzioni Options
	026 030 040 050 063 070	U F...	Vedere tabella <i>See tables</i>	 56.. — 100/112	B5 B14	SZDX SZSX DZ	BRDX BRSX *	0° 90° 180° 270°	VS
Versione Riduttore Gearbox Version		Albero di uscita Output shaft			Braccio di reazione Torque arm *		Angolo Angle		
									

* NOTA: il braccio di reazione viene fornito smontato.
NOTE: the torque arm will be supplied not assembled.

Sensi di rotazione

Direction of rotation

CL

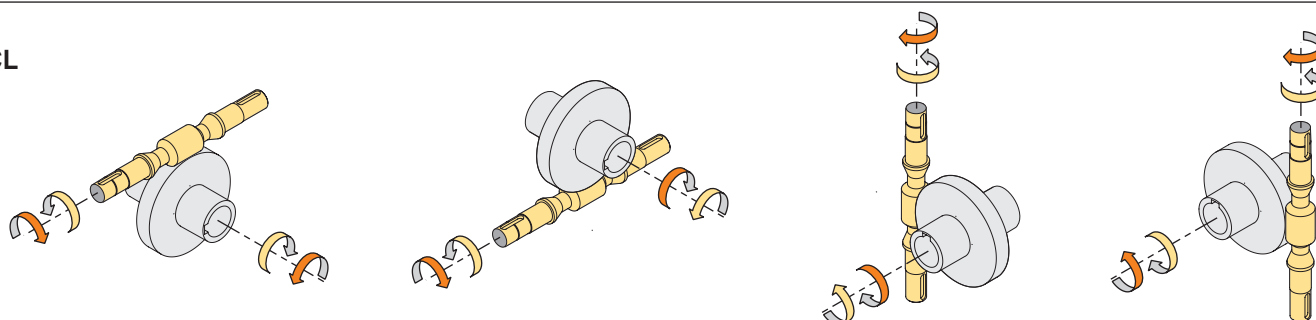

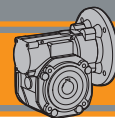

Simbologia

Symbols

n_1 [min ⁻¹]	Velocità in ingresso / <i>Input speed</i>	sf	Fattore di servizio / <i>Service factor</i>
n_2 [min ⁻¹]	Velocità in uscita / <i>Output speed</i>	R_d %	Rendimento dinamico / <i>Dynamic efficiency</i>
i	Rapporto di riduzione / <i>Ratio</i>	R_s %	Rendimento statico / <i>Static efficiency</i>
P_1 [kW]	Potenza in entrata / <i>Nominal input power</i>	R_2 [N]	Carico radiale ammissibile in uscita / <i>Permitted output radial load</i>
M_2 [Nm]	Coppia in uscita in funzione di P_1 / <i>Output torque referred to P_1</i>	A_2 [N]	Carico assiale ammissibile in uscita / <i>Permitted output axial load</i>
P_{n1} [kW]	Potenza nominale in entrata / <i>Nominal input power</i>	Z	Numero di principi della vite / <i>Worm starts</i>
M_{n2} [Nm]	Coppia nominale in uscita in funzione di P_{n1} / <i>Nominal output torque referred to P_{n1}</i>	β	Angolo d'elica / <i>Helix angle</i>

Lubrificazione

Lubrication

Tutti i motoriduttori sono forniti completi di lubrificante sintetico viscosità 320, pertanto possono essere installati in qualunque posizione di montaggio e non necessitano di manutenzione.

Permanent synthetic oil long-life lubrication (viscosity grade 320) makes it possible to use the gearmotors in all mounting positions; for this reason they can be installed in any assembly position and do not require maintenance.

Carichi radiali

Radial loads

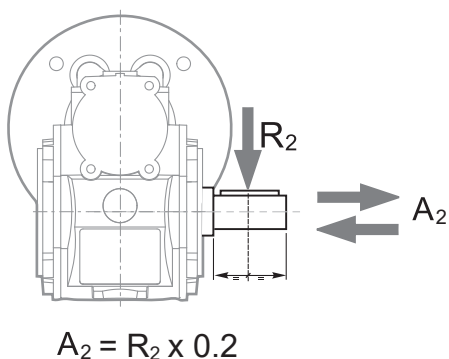

n_2 [min ⁻¹]	R_2 [N]					
	CL026	CL030	CL040	CL050	CL063	CL070
187	400	674	1264	1770	2445	2613
140	490	743	1392	1949	2692	2878
93	580	851	1596	2234	3085	3298
70	610	936	1754	2456	3392	3626
56	610	1008	1890	2646	3654	3906
47	610	1069	2004	2805	3874	4141
35	610	1179	2210	3095	4273	4568
28	610	1270	2381	3334	4603	4921
23	610	1356	2542	3559	4915	5254
18	610	1471	2759	3862	5334	5702
14	610	1600	3000	4200	5800	6200

Quando il carico radiale risultante non è applicato sulla mezzzeria dell'albero occorre calcolare quello effettivo con la seguente formula:

When the resulting radial load is not applied on the centre line of the shaft it is necessary to calculate the effective load with the following formula:

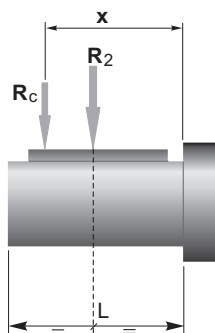

	CL	CL / CLP				
	026	030	040	050	063	070
a	56	65	84	101	120	122
b	43	50	64	76	95	92
R_{2MAX}	610	1600	3000	4200	5800	6200

$$R_c = \frac{R_2 \cdot a}{(b + x)} \leq R_{2MAX}$$

*a, b = valori riportati nella tabella
a, b = values given in the table*

$$R \leq R_c$$

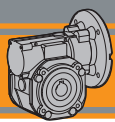

CL

Motoriduttori a vite senza fine
Wormgearmotors

Dati di dentatura

Toothing data

	Dati della coppia vite-corona Worm wheel data	Rapporto / Ratio											
		5	7.5	10	15	20	25	30	40	50	60	80	100
CL026	Z	6	4	3	2	2		1	1	1	1		
	β	34° 35'	24° 41'	19° 1'	12° 57'	10° 30'		6° 33'	5° 17'	4° 26'	3° 49'		
CL030	Z	6	4	3	2	2	2	1	1	1	1	1	1
	β	27° 4'	24° 28'	18° 50'	12° 49'	10° 23'	8° 43'	6° 29'	5° 14'	4° 23'	3° 46'	2° 57'	2° 25'
CL040	Z	6	4	3	2	2	2	1	1	1	1	1	1
	β	34° 19'	24° 28'	18° 50'	12° 49'	10° 23'	8° 43'	6° 29'	5° 14'	4° 23'	3° 46'	2° 57'	2° 25'
CL050	Z	6	4	3	2	2	2	1	1	1	1	1	1
	β	33° 37'	23° 54'	18° 23'	12° 29'	10° 6'	8° 28'	6° 19'	5° 5'	4° 15'	3° 39'	2° 51'	2° 20'
CL063	Z	6	4	3	2	2	2	1	1	1	1	1	1
	β	34° 23'	24° 31'	18° 53'	12° 50'	10° 24'	8° 44'	6° 30'	5° 14'	4° 23'	3° 47'	2° 57'	2° 25'
CL070	Z		4	3	2	2	2	1	1	1	1	1	1
	β		26° 12'	20° 15'	13° 49'	11° 15'	9° 29'	7° 0'	5° 41'	4° 46'	4° 7'	3° 13'	2° 39'

Rendimento

Efficiency

	n_1 [min ⁻¹]	Rendimento Efficiency	Rapporto / Ratio											
			5	7.5	10	15	20	25	30	40	50	60	80	100
CL026	2800	Rd	89	87	85	83	80		73	68	64	60		
	1400		87	84	83	78	74		66	61	57	53		
	900		84	83	80	75	71		61	57	52	48		
			Rs	72	71	68	61	56	46	41	36	34		
CL030	2800	Rd	89	88	86	84	81	78	74	70	65	62	57	52
	1400		86	85	84	79	75	72	67	62	58	55	48	43
	900		84	83	81	75	71	68	62	58	53	49	43	39
			Rs	72	67	63	55	50	43	39	35	31	27	23
CL040	2800	Rd	90	89	87	84	83	80	77	73	69	66	60	56
	1400		88	86	84	81	78	74	70	65	60	58	52	46
	900		86	84	82	77	74	70	66	60	57	53	46	41
			Rs	74	71	67	60	55	51	45	40	36	32	28
CL050	2800	Rd	91	90	88	86	84	82	78	74	71	68	62	58
	1400		89	87	85	82	79	76	72	67	63	60	54	49
	900		87	85	84	79	75	72	68	62	59	55	48	43
			Rs	73	70	66	59	55	51	44	39	35	32	27
CL063	2800	Rd	91	90	88	86	84	83	79	76	73	70	65	60
	1400		90	88	86	84	81	78	75	70	66	63	57	52
	900		89	86	84	81	78	75	70	65	61	58	52	47
			Rs	73	71	67	60	55	51	45	40	36	33	28
CL070	2800	Rd		90	89	87	85	84	80	77	74	72	67	62
	1400			89	87	84	82	80	76	72	68	65	60	53
	900			87	85	82	79	77	72	67	63	60	54	49
			Rs		72	69	62	60	55	48	43	38	36	31



Rendimento teorico del riduttore dopo il rodaggio
Theoretical efficiency of the gearbox after the first running period

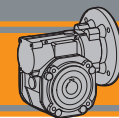

Motori applicabili

IEC Motor adapters

	IEC	N	M	P	D	i																	
						5	7.5	10	15	20	25	30	40	50	60	80	100						
CL026	56B14	50	65	80	9																		
CL030	63B5	95	115	140	11																		
	63B14	60	75	90																			
	56B5	80	100	120	9	B	B	B	B	B	B	B	B	B									
	56B14	50	65	80																			
CL040	71B5	110	130	160	14																		
	71B14	70	85	105																			
	63B5	95	115	140	11	B	B	B	B	B	B	B	B										
	63B14	60	75	90																			
	56B5	80	100	120	9	BS	BS	BS	BS	BS	BS	BS	BS	B	B	B	B						
	56B14	50	65	80																			
CL050	80B5	130	165	200	19																		
	80B14	80	100	120																			
	71B5	110	130	160	14	B	B	B	B	B	B	B											
	71B14	70	85	105																			
	63B5	95	115	140	11	BS	BS	BS	BS	BS	BS	BS	B	B	B	B							
	63B14	60	75	90																			
CL063	90B5	130	165	200	24																		
	90B14	95	115	140																			
	80B5	130	165	200	19	B	B	B	B	B	B	B											
	80B14	80	100	120																			
	71B5	110	130	160	14	BS	BS	BS	BS	BS	BS	BS	B	B	B								
	71B14	70	85	105																			
	63B5	95	115	140	11									BS	BS	BS	B	B					
CL070	100/112B5	180	215	250	28																		
	100/112B14	110	130	160																			
	90B5	130	165	200	24		B	B	B	B													
	90B14	95	115	140																			
	80B5	130	165	200	19		BS	BS	BS	BS	B	B	B										
	80B14	80	100	120																			
	71B5	110	130	160	14						BS	BS	BS	B	B	B	B						

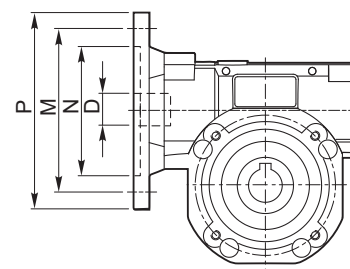

N.B.

Le aree evidenziate in grigio indicano l'applicabilità della corrispondente grandezza motore.

N.B. Grey areas indicate motor inputs available on each size of unit.

B/BS = Boccia di riduzione in acciaio

B/BS = Metal shaft sleeve

Nota: flange Nema disponibili a richiesta
Note: Nema flange available on demand

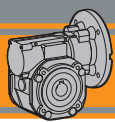

Dimensioni

Dimensions

CL 026 U

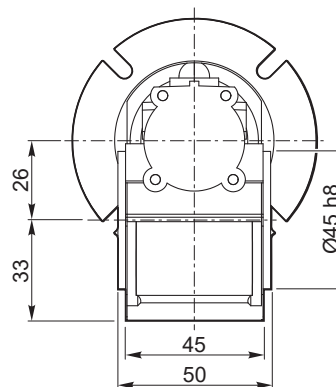
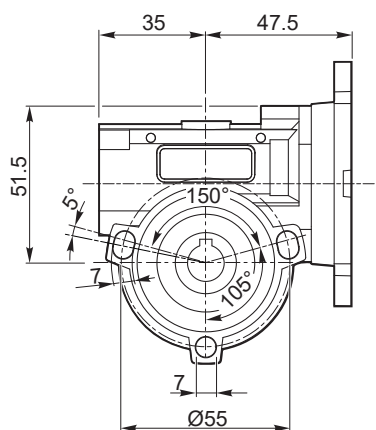

Kg
0.7

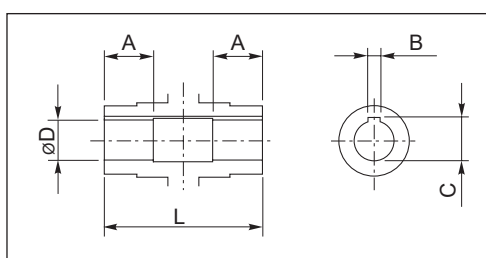

Albero lento cavo / Hollow output shaft

Grandezza Size	Ø D H8	L	A	B	C
CL 026	12	50	15	4	13.8

CL 026 F

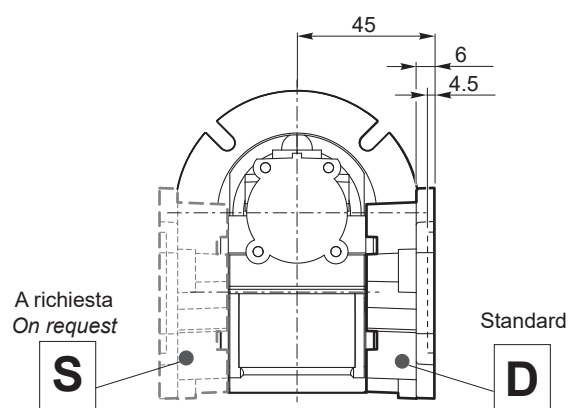
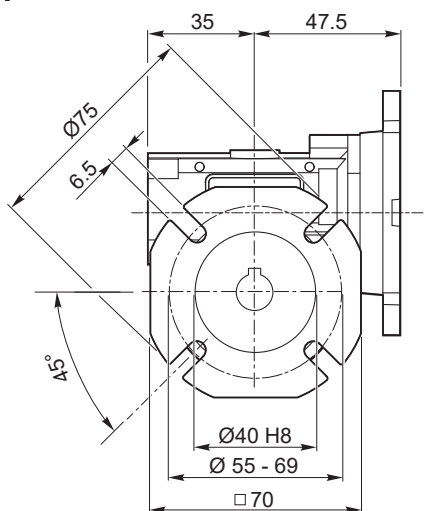

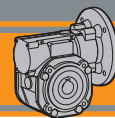

Dimensioni

Dimensions

CL 030 U

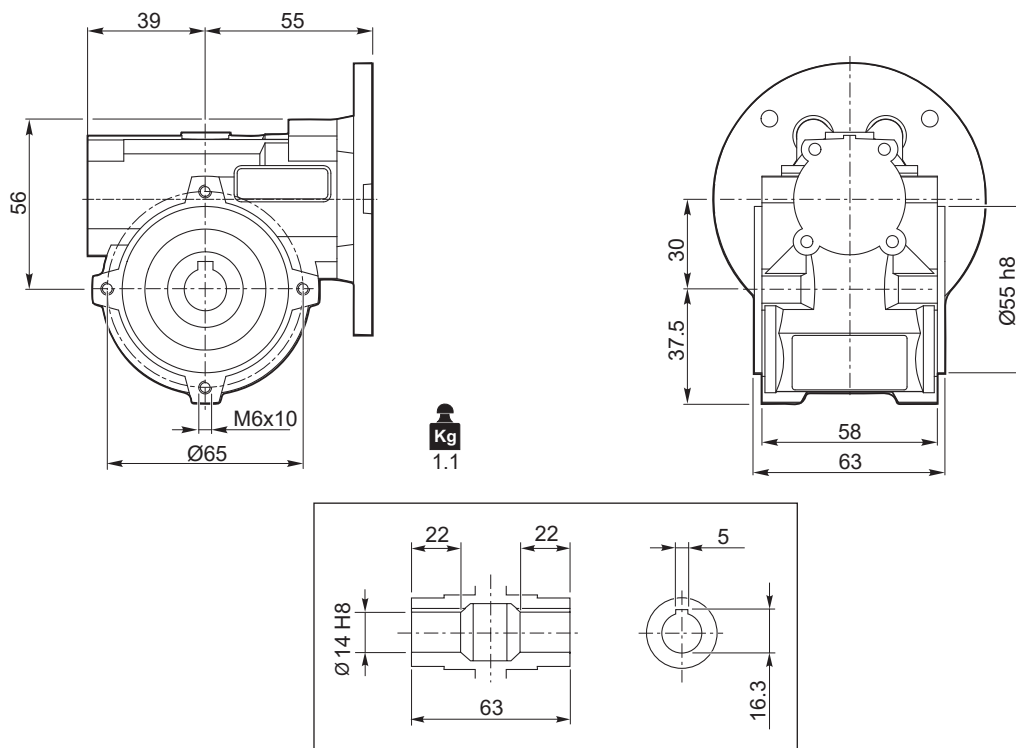

Albero lento cavo / Hollow output shaft

CL 030 F

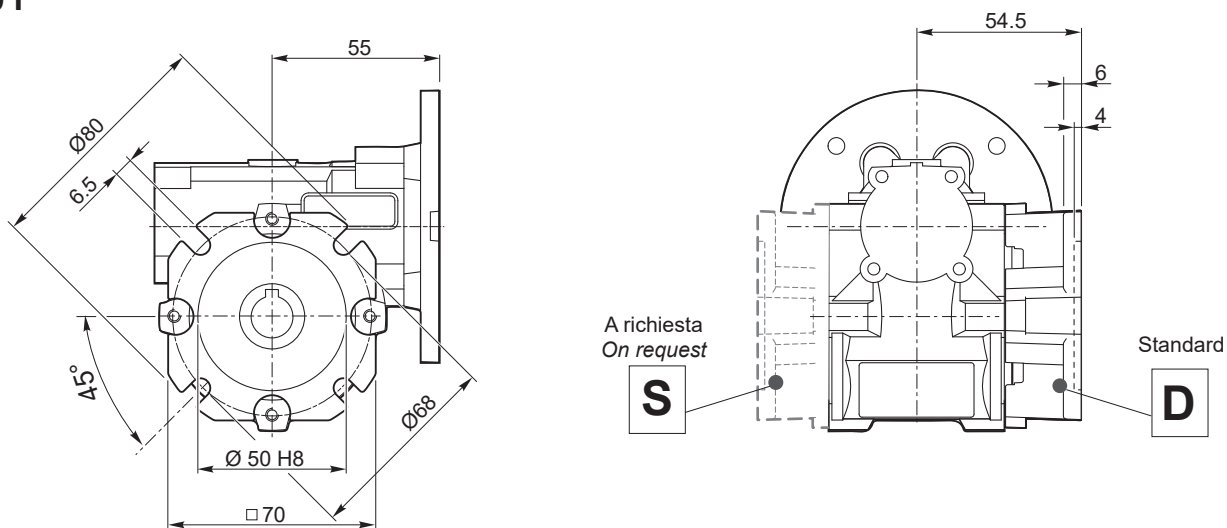

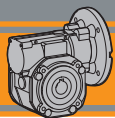
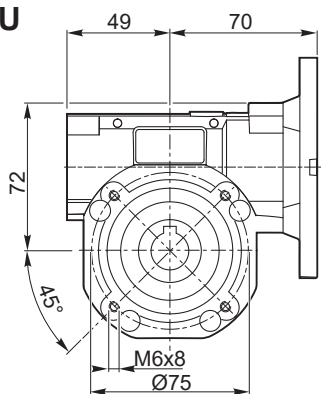
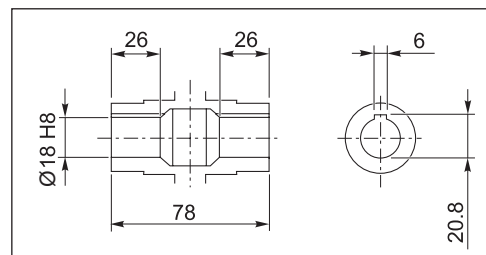
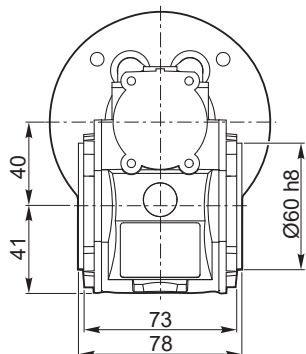
**CL****Motoriduttori a vite senza fine**
Wormgearmotors**Dimensioni****Dimensions****CL 040 U****Kg**
2.1

Albero lento cavo / Hollow output shaft

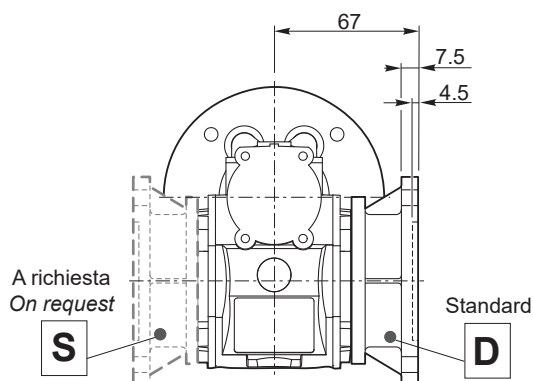
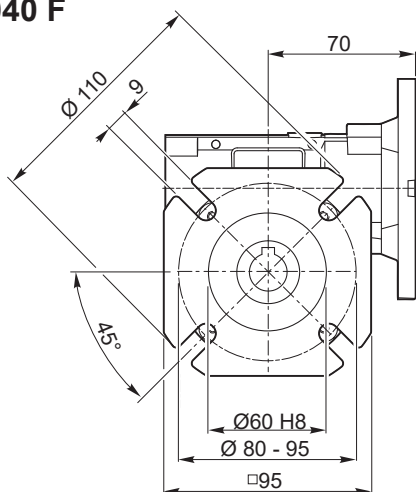
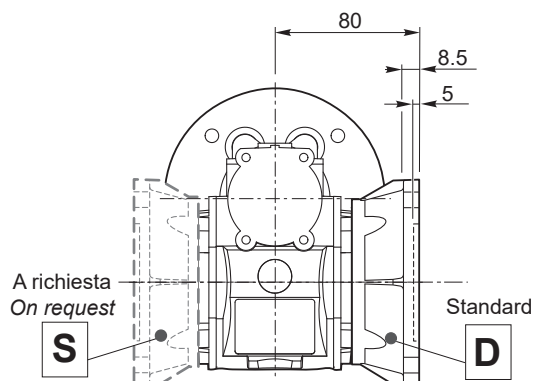
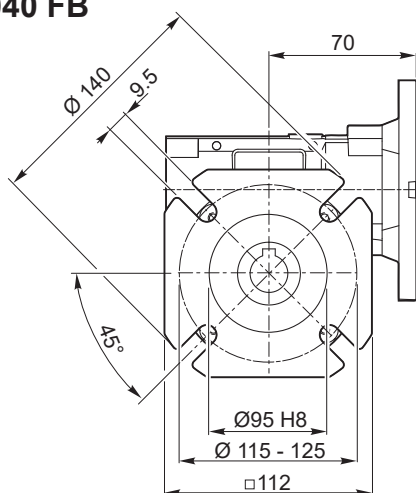
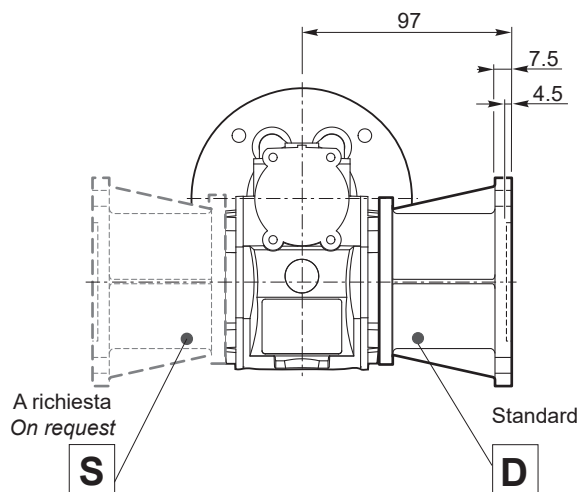
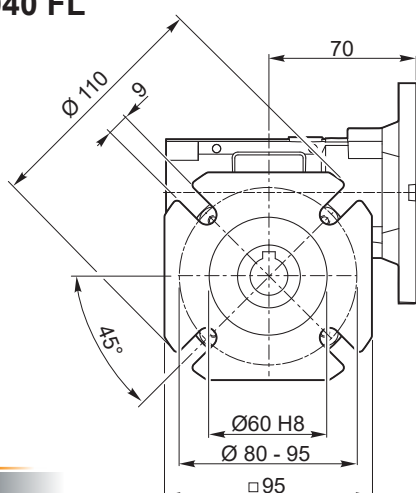
CL 040 F**CL 040 FB****CL 040 FL**

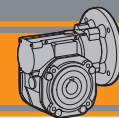

Dimensioni

Dimensions

CL 050 U

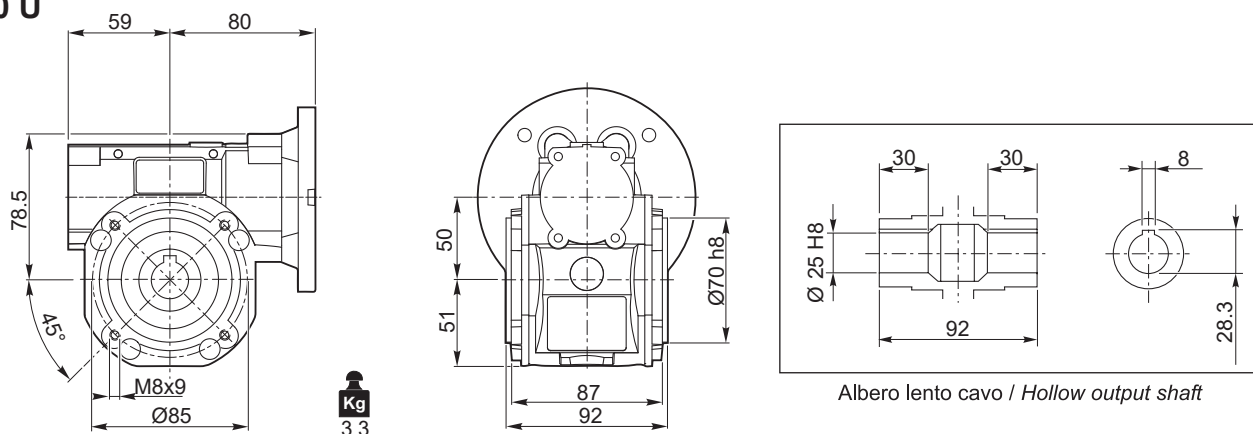

CL 050 F

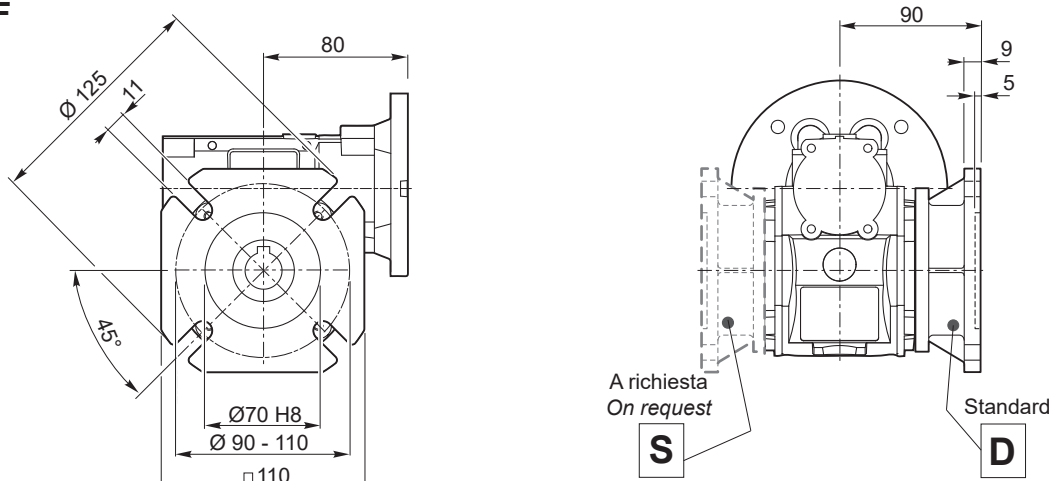

CL 050 FB

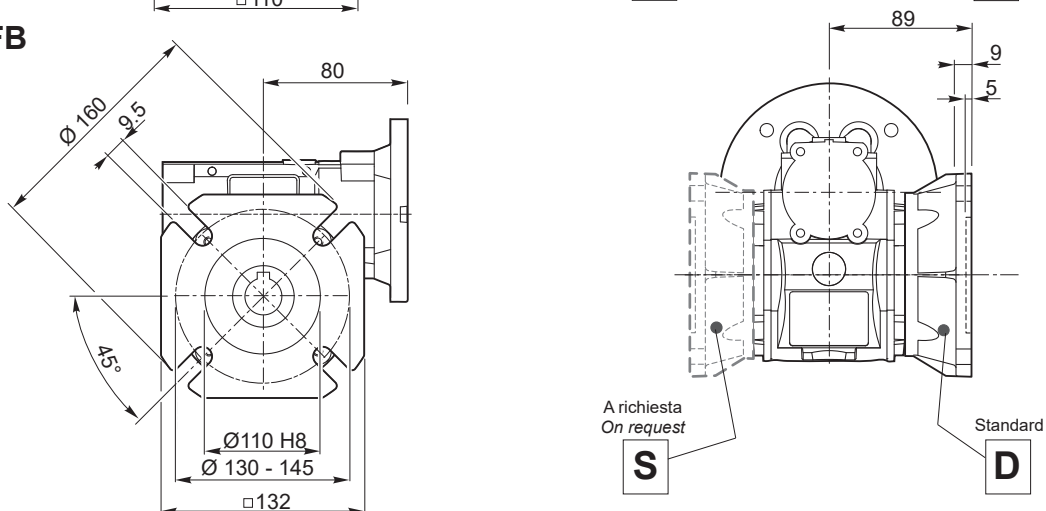

CL 050 FL

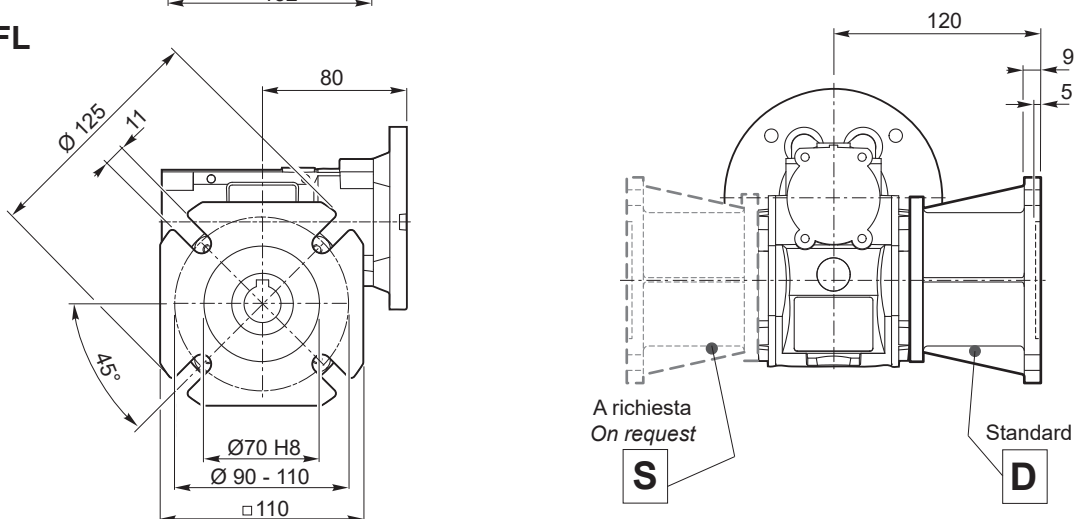

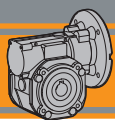
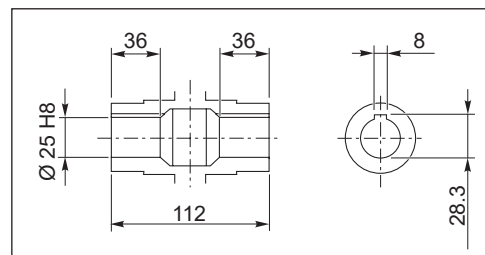
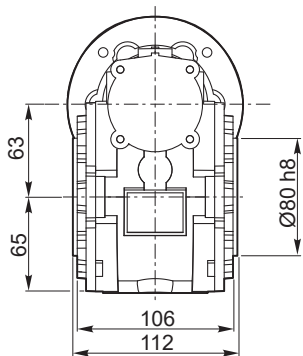
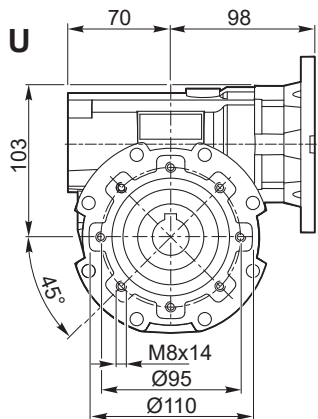
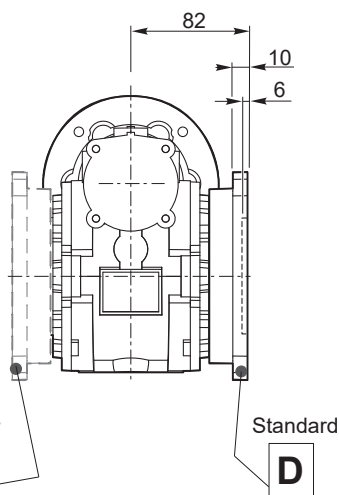
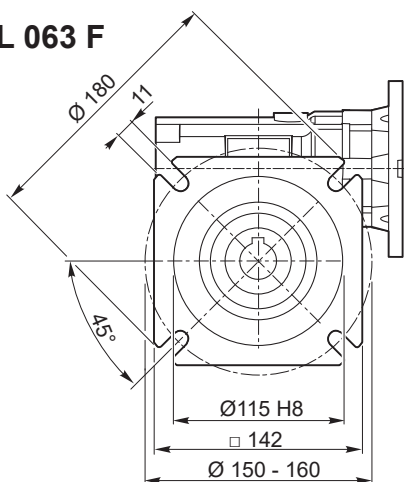
**CL****Motoriduttori a vite senza fine**
Wormgearmotors**Dimensioni****Dimensions****CL 063 U**Albero lento cavo / *Hollow output shaft***Kg**
6.0**CL 063 F**A richiesta
On request

Standard

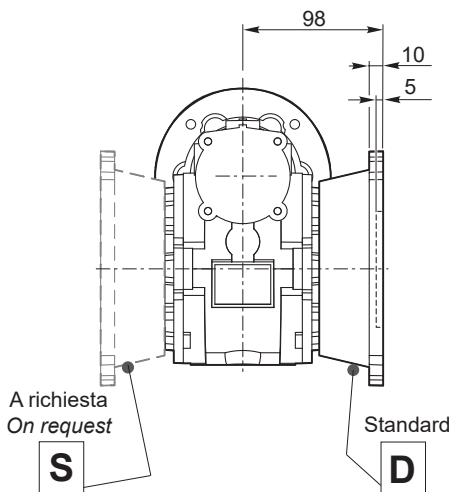
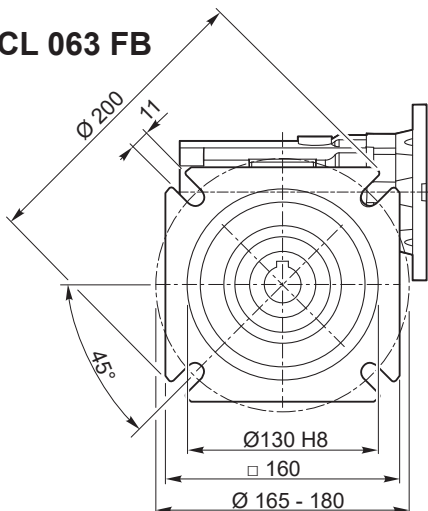
CL 063 FBA richiesta
On request

Standard

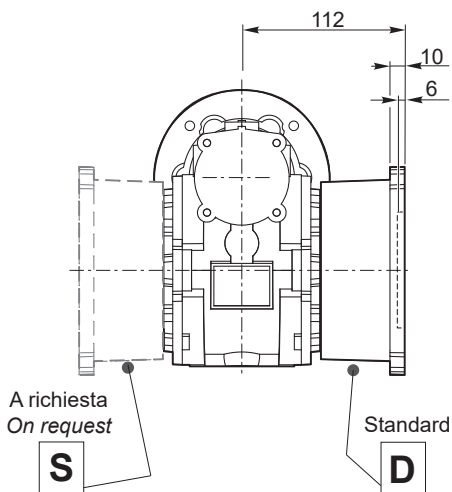
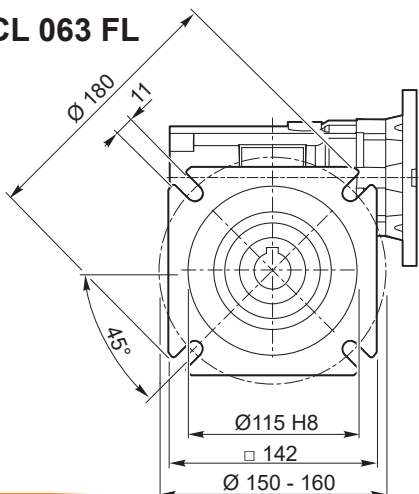
CL 063 FLA richiesta
On request

Standard

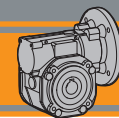

Dimensioni

Dimensions

CL 070 U

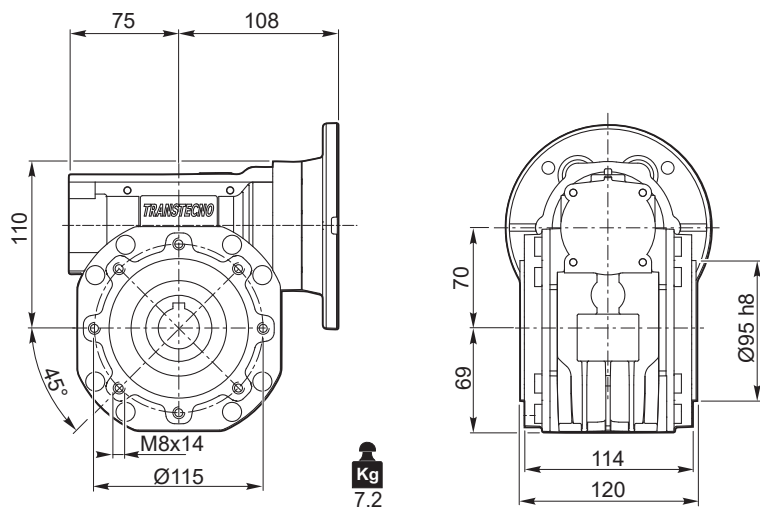

Kg
7.2

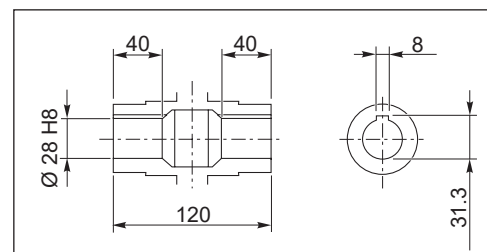

Albero lento cavo / Hollow output shaft

CL 070 F

CLP../070 F

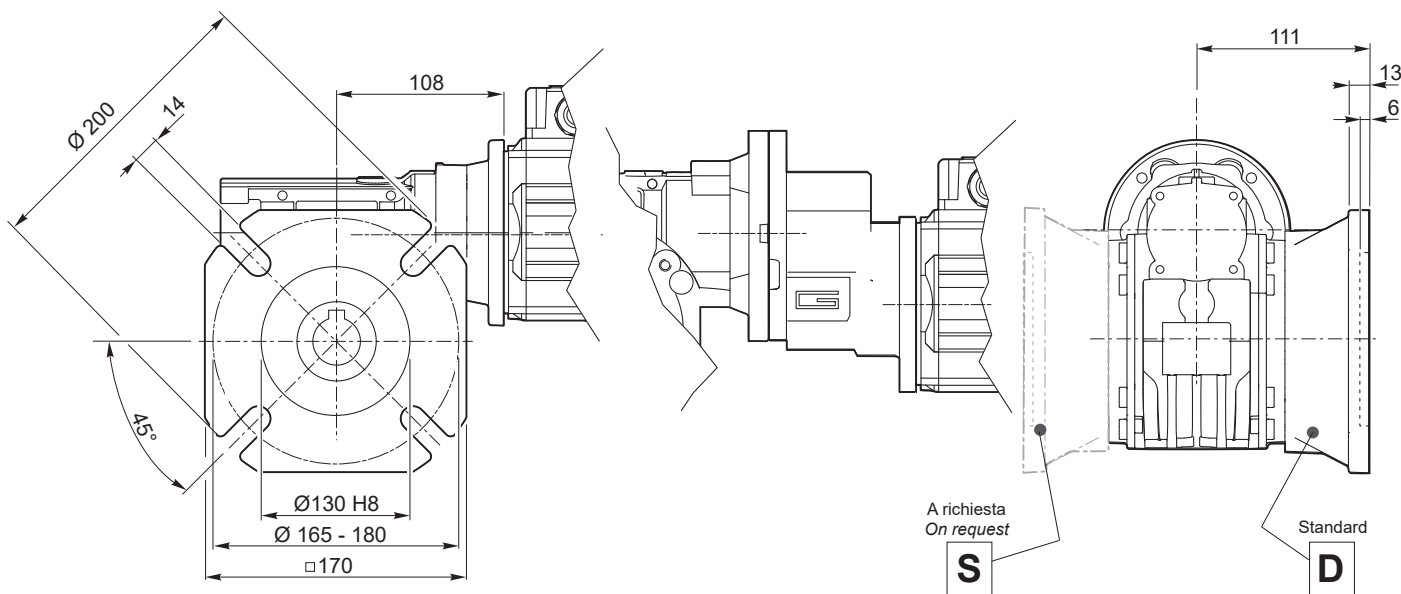

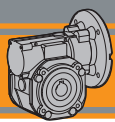

Accessori

Accessories

Albero lento semplice e doppio

Single and double output shaft

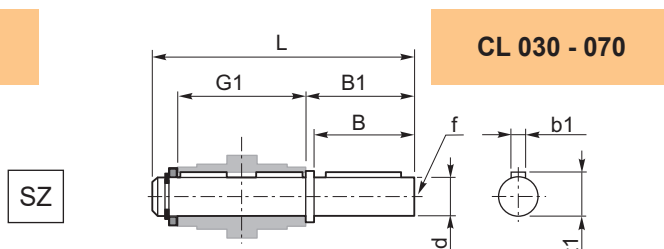
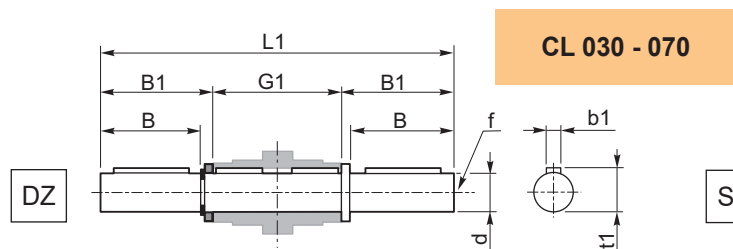

CL	d _{h7}	B	B1	G1	L	L1	f	b1	t1
030	14	30	32.5	63	102	128	M6	5	16
040	18	40	43	78	128	164	M6	6	20.5
050	25	50	53.5	92	153	199	M10	8	28
063	25	50	53.5	112	173	219	M10	8	28
070	28	60	63.5	120	192	247	M10	8	31

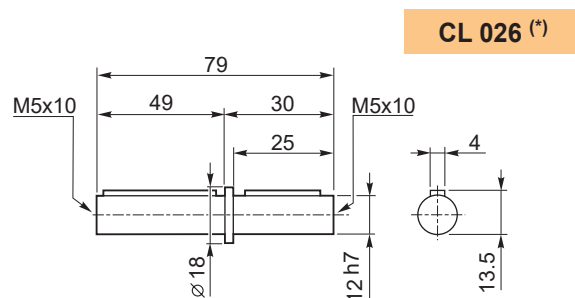

(*)
Nota: disponibile solo per cavo uscita Ø12
Note: available for output hollow shaft Ø12 only

Braccio di reazione

Torque arm

CL	K1	G	KG	KH	R
030	85	14	23	8	15
040	100	14	31	10	18
050	100	14	38	10	18
063	150	14	47.5	10	18
070	200	25	46.5	20	30

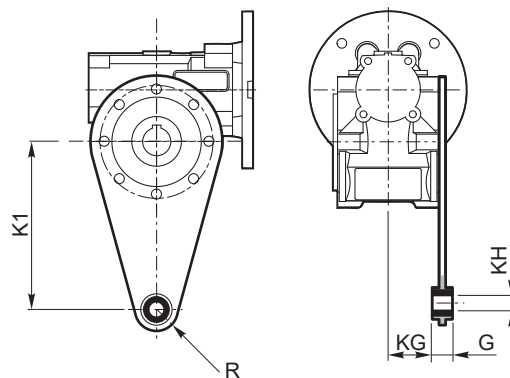

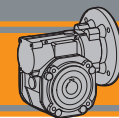

Accessori

Accessories

SC - Safety Cover

CL	M
030	47
040	54.5
050	62.5
063	73
070	75

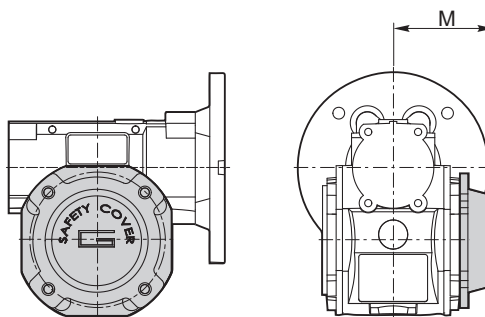

WD - Kit washdown cover

CL	M
026*	37.5
030	48
040	55.5
050	63.5
063	71.5
070	76

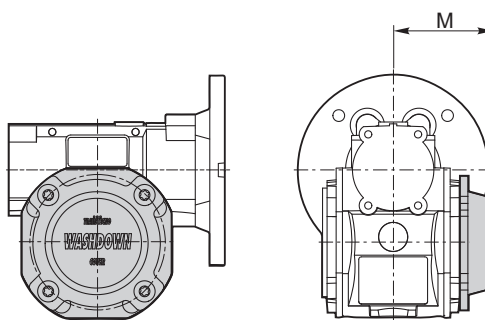

(*)
Nota: Viti escluse dalla fornitura
Note: Screws not provided

Opzioni

Options

VS - Vite sporgente / Extended input shaft

CL	A	B	D ₁ j6	E	F	G
030	45	20	9	M4	3	10.2
040	53	23	11	M5	4	12.5
050	64	30	14	M6	5	16
063	75	40	19	M6	6	21.5
070	84	40	19	M6	6	21.5

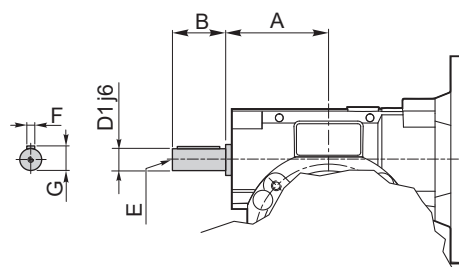

 Costruito su richiesta
Built on request

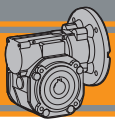

CL

Motoriduttori a vite senza fine
Wormgearmotors

Note/Notes

 **TRANSTECNO SRL
HEADQUARTERS**

Company subject to the management
and coordination of INTERPUMP GROUP SPA
Via Caduti di Sabbiano, 11/D-E
40011 Anzola dell'Emilia (BO)
ITALY
T+39 051 64 25 811
F +39 051 73 49 43
sales@transtecno.com
www.transtecno.com

the modular gearmotor

MEMBER OF INTERPUMP GROUP



 **HANGZHOU INTERPUMP
POWER TRANSMISSIONS CO LTD**
No.4 Xiuyan Road Fengdu Industry Zone
Pingyao Town Yuhang District
Hangzhou City, Zhejiang Province
311115 – CHINA
T +86 571 86 92 02 60
info-china@transtecno.cn
www.transtecno.cn

 **TRANSTECNO IBÉRICA
THE MODULAR GEARMOTOR, S.A.**
Carrer de la Ciència, 45
08840 Viladecans (Barcelona) - SPAIN
T +34 931 598 950
info@transtecno.es
www.transtecno.es

 **TRANSTECNO B.V.**
Siliciumweg 32
3812 SX Amersfoort – NETHERLANDS
T +31(0) 33 45 19 505
info@transtecno.nl
www.transtecno.nl

 **TRANSTECNO AANDRIJFTECHNIEK B.V.**
Siliciumweg 32
3812 SX Amersfoort – NETHERLANDS
T +31 (0) 33 20 4 7 006
info@transtecnoaandrijftechnik.nl
www.transtecnoaandrijftechnik.nl

 **MA TRANSTECNO S.A.P.I. DE C.V.**
Av. Mundial # 176, Parque Industrial
JM Apodaca, Nuevo León,
C.P. 66633 - MÉXICO
T +52 8113340920
info@transtecno.com.mx
www.transtecno.com.mx

 **TRANSTECNO USA**
8 Creek Parkway,
Boothwyn PA 19061-8136 - UNITED STATES
T + 1 (610) 4970154

TRANSTECNO USA – WEST COAST BRANCH
14561 Fryelands Blvd SE
Monroe, WA 98272 - UNITED STATES
T +1 360-863-1300
usaoffice@transtecno.com
www.transtecno.com

 **TRANSTECNO CANADA**
51 B Caldari Road Unit 10
Vaughan, ON L4K 4G3 - CANADA
T +1 905 761 0762
canadaoffice@transtecno.com
www.transtecno.com

 **TRANSTECNO INDIA**
#6A, Sipcot Industrial complex, Phase-1,Elasagiri Road
Hosur – 635126 Tamilnadu - INDIA
T +91 4344 274434
M +91 81443 88800

TRANSTECNO INDIA – NORTH BRANCH
Plot No: 3 A, Sector 2, IIE, Sidcul, Pantnagar
U.S. Nagar, Uttarakhand – 263153 - INDIA
indiaoffice@transtecno.com
www.transtecno.com

 **TRANSTECNO BRAZIL**
Rua Gilberto de Zorzi, 525 Forqueta – CEP. 95115-730
CX Postal 3544 Caxias do Sul RS – BRAZIL

TRANSTECNO BRAZIL – SÃO PAULO BRANCH
R. Mafalda Barnabe Soliane, 314 – CEP. 13347-610
Indaiatuba, São Paulo - BRAZIL
T +55 19 3437 2520

TRANSTECNO BRAZIL – PORTO ALEGRE BRANCH
Rua Dr. Freire Alemão 155 / 402 - CEP. 90450-060
Auxiliadora Porto Alegre RS - BRAZIL
T +55 51 3251 5447
M +55 51 811 45 962
braziloffice@transtecno.com
www.transtecno.com.br

 **INTERPUMP ANTRIEBSTECHNIK GMBH**
Büro Stuttgart - GERMANY
T +49 (0)171 4781909
germanoffice@transtecno.com
www.transtecno.com

 **SALES OFFICE OCEANIA**
Unit 5, 12 Nyholt Drive, Yatala 4207
Queensland - AUSTRALIA
T +61 07 3800 0103
M +61 04 38060997

 **UNIT 9, 94 Boundary Rd, Sunshine West 3020
Victoria - AUSTRALIA
T +61 9312 4722
oceaniaoffice@transtecno.com
www.transtecno.com.au**