

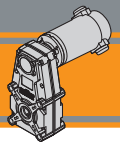

Ferrite

Motoriduttori CC pendolari
DC helical parallel gearmotors





Indice	Index	Pag. Page
Caratteristiche tecniche	<i>Technical features</i>	N2
Designazione	<i>Classification</i>	N2
Sensi di rotazione	<i>Direction of rotation</i>	N3
Simbologia	<i>Symbols</i>	N3
Lubrificazione	<i>Lubrication</i>	N3
Carichi radiali	<i>Radial loads</i>	N4
Dati tecnici	<i>Technical data</i>	N5
Motori applicabili	<i>Motor adapters</i>	N7
Dimensioni	<i>Dimensions</i>	N8

Questa sezione annulla e sostituisce ogni precedente edizione o revisione. Qualora questa sezione non Vi sia giunta in distribuzione controllata, l'aggiornamento dei dati ivi contenuto non è assicurato. **In tal caso la versione più aggiornata è disponibile sul nostro sito internet www.transtecno.com**

This section replaces any previous edition and revision. If you obtained this catalogue other than through controlled distribution channels, the most up to date content is not guaranteed. In this case the latest version is available on our web site www.transtecno.com

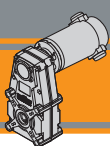

Caratteristiche tecniche

Technical features

I motoriduttori CC pendolari a magneti permanenti in ferrite ECFT hanno le seguenti caratteristiche principali:

ECFT ferrite permanent magnets DC helical parallel gearmotors range has the following main features:

- Alimentazione in bassa tensione 12/24 Vcc
- Possibilità di montaggio encoder e freno
- Potenze motore disponibili da 100 a 800W S2
- Magneti in ferrite
- Carcasa pressofusione di alluminio
- Lubrificazione permanente con olio sintetico.
- Ingranaggi cilindrici a denti elicoidali.

- Low voltage power supply 12/24 Vdc
- Suitable for encoder and brake assembly
- Motor power ratings available from 100 to 800W S2
- Ferrite magnets
- Die-cast aluminum housings
- Permanent synthetic oil long-life lubrication.
- helical gears.

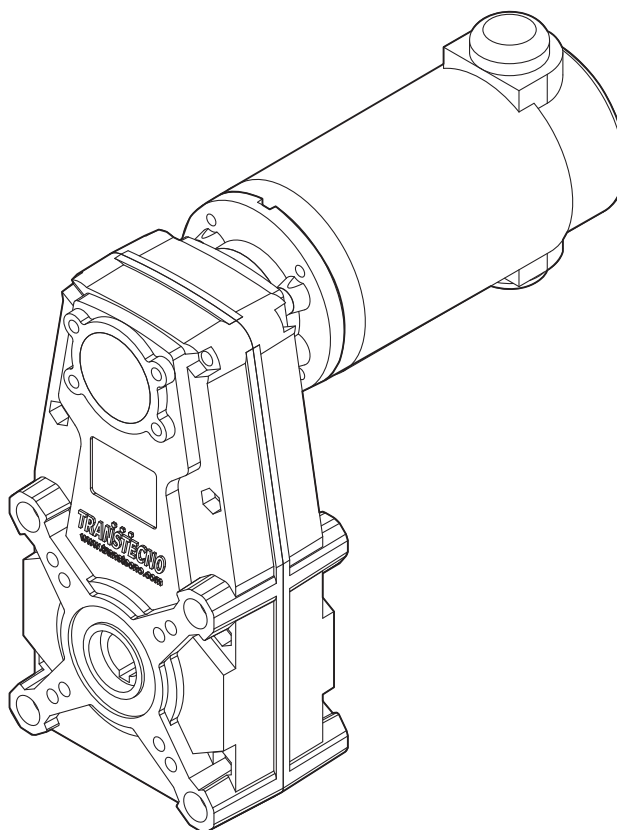

Designazione

Classification

MOTORIDUTTORE / GEARMOTORS										
ECFT	180/146						U	60.63	O20	240
Tipo Type	Grandezza Size						Versione Version	Rapporto Ratio	Albero cavo uscita Hollow output shaft	Versione motore Motor version
	070/105/3	100/105/3	180/105/3	250/146	350/146	600/146	U...	vedi tabelle see tables	vedi tabelle see tables	120
	070/105/4	100/146	180/146	250/176	350/176	600/176				
	070/146		180/176	250/196	350/196	600/196				
			180/196							

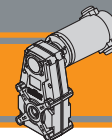

Sensi di rotazione

Direction of rotation

FT105/3
FT146
FT176
FT196

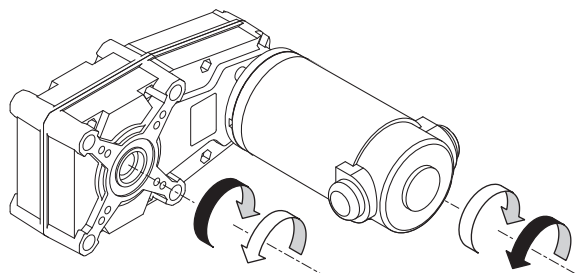
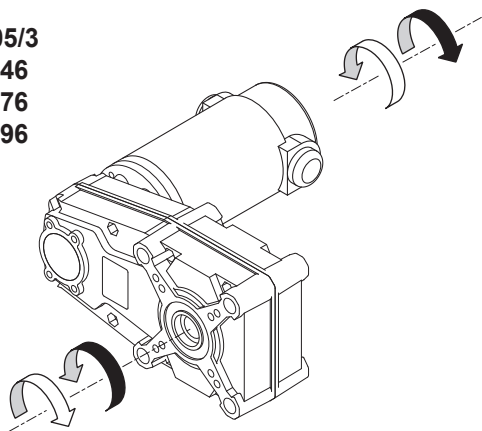

FT105/4

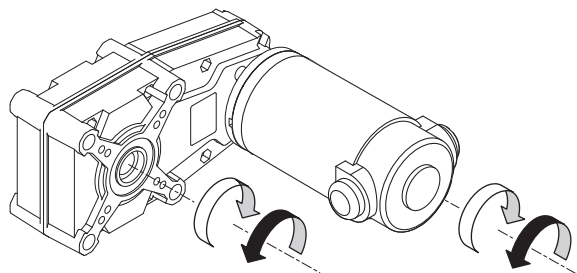
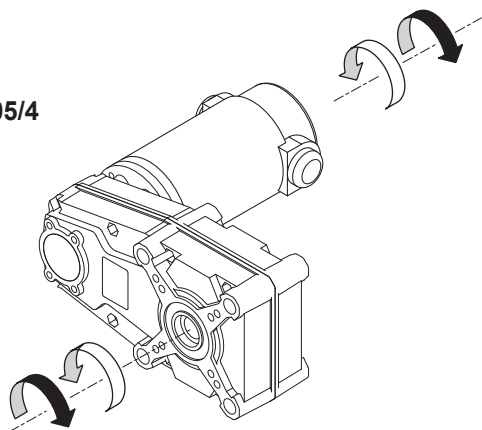

Simbologia

Symbols

n_1	[min^{-1}]	Velocità in ingresso / <i>Input speed</i>
n_2	[min^{-1}]	Velocità in uscita / <i>Output speed</i>
i		Rapporto di riduzione / <i>Ratio</i>
P_1	[kW]	Potenza in entrata / <i>Input power</i>
M_2	[Nm]	Coppia nominale in uscita in funzione di P_1 / <i>Output torque referred to P_1</i>
P_{n1}	[kW]	Potenza nominale in entrata / <i>Nominal input power</i>
M_{n2}	[Nm]	Coppia nominale in uscita in funzione di P_{n1} / <i>Nominal output torque referred to P_{n1}</i>
sf		Fattore di servizio / <i>Service factor</i>
R_2	[N]	Carico radiale ammissibile in uscita / <i>Permitted output radial load</i>
A_2	[N]	Carico assiale ammissibile in uscita / <i>Permitted output axial load</i>

Lubrificazione

Lubrication

Tutti i motoriduttori sono forniti completi di lubrificante sintetico viscosità 320, pertanto possono essere installati in qualunque posizione di montaggio e non necessitano di manutenzione.

Permanent synthetic oil long-life lubrication (viscosity grade 320) makes it possible to use the gearmotors in all mounting positions; for this reason they can be installed in any assembly position and do not require maintenance.

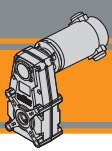

Carichi radiali

Radial loads

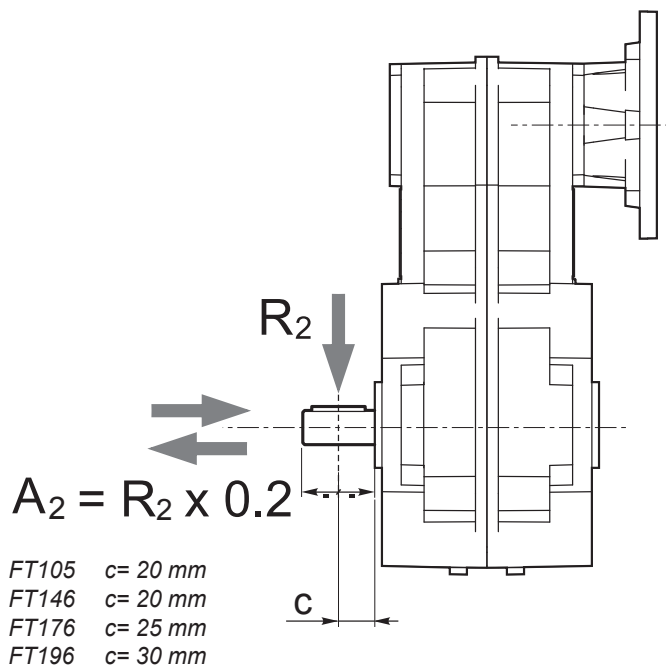

n ₂ [min ⁻¹]	R ₂ [N]			
	FT105	FT146	FT176	FT196
200	800	1400	2000	2200
170	900	1600	2200	2400
140	1000	1800	2400	2600
120	1100	2000	2600	2800
100	1300	2200	2800	3100
70	1500	2500	3000	3500
50	1600	2600	3250	3750
40	1700	2700	3500	4000
30	1850	2850	4000	4600
20	2000	3000	4500	5500
10	2000	3000	5000	7000
5	2000	3000	5000	7000

Quando il carico radiale risultante non è applicato sulla mezzeria dell'albero occorre calcolare quello effettivo con la seguente formula:

When the resulting radial load is not applied on the centre line of the shaft it is necessary to calculate the effective load with the following formula:

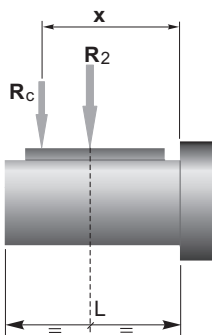

	FT105	FT146	FT176	FT196
a	82	82,5	115	132
b	62	62,5	90	102
R _{2MAX}	2000	3000	5000	7000

$$R_c = \frac{R_2 \cdot a}{(b + x)} \leq R_{2MAX}$$

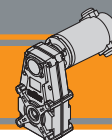

$$R \leq R_c$$

a, b = valori riportati nella tabella
a, b = values given in the table



Dati tecnici

Technical data

P ₁ [W]	n ₂ [min ⁻¹]	M ₂ [Nm]	sf	i		Versione motore Motor version	P ₁ [W]	n ₂ [min ⁻¹]	M ₂ [Nm]	sf	i		Versione motore Motor version	
100							140							
(3000 min ⁻¹)	146	6	5.1	20.57	070/105/3	12E/24E	(3000 min ⁻¹)	41	31	2.8	74.02	100/146	120/240/24E*	
	90	10	3.9	33.32		120.66/240.66		35	35	2.4	84.63		120.66/240.66	
	68	13	3.8	44.36				31	40	2.1	95.61			
	55	16	3.1	54.87				26	48	1.8	113.40			
	42	21	2.4	71.84				22	56	1.5	133.45			
	39	23	2.2	77.07				20	63	1.4	150.18			
	34	27	1.9	88.87				19	67	1.4	160.43			
	24	37	1.4	124.81				17	75	1.2	178.83			
	17	54	0.9	181.35				15	82	1.1	195.85			
	13	67	0.8	224.32				13	94	1.0	223.92			
	9.5	86	0.6	315.05			13	99	0.9	236.83				
							10	126	0.7	300.07				
	8.1	86	0.6	368.19	070/105/4	12E/24E	250							
	5.6	86	0.6	534.98		120.66/240.66								
	4.5	86	0.6	661.76										
	3.2	86	0.6	929.40										
	160	6	11.1	18.75	070/146	12E/24E	(3000 min ⁻¹)	146	15	2.0	20.57	180/105/3	120/240	
	131	7	9.1	22.89		120.66/240.66		90	25	1.6	33.32		120.66/240.66	
	115	8	8.0	26.17				68	33	1.5	44.36			
	106	8	7.4	28.26				55	41	1.2	54.87			
	86	10	7.4	35.07				42	54	0.9	71.84			
	76	12	6.6	39.44				39	58	0.9	77.07			
	65	14	5.6	46.44				34	66	0.8	88.87			
	57	16	4.9	52.86				160	14	4.4	18.75		180/146	120/240/24E*
	49	18	4.7	60.63				131	17	3.6	22.89			120.66/240.66
	43	21	4.1	70.00				115	20	3.2	26.17			
	41	22	3.9	74.02				106	21	3.0	28.26			
	35	25	3.4	84.63				86	26	3.0	35.07			
	31	29	3.0	95.61				76	30	2.6	39.44			
	26	34	2.5	113.40				65	35	2.2	46.44			
	22	40	2.1	133.45				57	40	2.0	52.86			
	20	45	1.9	150.18				49	45	1.9	60.63			
	19	48	1.9	160.43			43	52	1.6	70.00				
	17	54	1.7	178.83			41	55	1.5	74.02				
	15	59	1.6	195.85			35	63	1.4	84.63				
	13	67	1.4	223.92			31	72	1.2	95.61				
	13	71	1.3	236.83			26	85	1.0	113.40				
	10	90	1.0	300.07			22	100	0.9	133.45				
	7.5	119	0.8	397.38			20	112	0.8	150.18				
							19	120	0.8	160.43				
							17	134	0.7	178.83				
140							140							
(3000 min ⁻¹)	146	9	3.6	20.57	100/105/3	120/240/24E	*: Motore inclinato con portaspazzole a 45° Motor assembly with brush holder inclined 45°							
	90	14	2.8	33.32		120.66/240.66								
	68	19	2.7	44.36										
	55	23	2.2	54.87										
	42	30	1.7	71.84										
	39	32	1.6	77.07										
	34	37	1.4	88.87										
	24	52	1.0	124.81										
	16.5	76	0.7	181.35										
	160	8	7.9	18.75		100/146							120/240/24E*	
	131	10	6.5	22.89	120.66/240.66									
	115	11	5.7	26.17										
	106	12	5.3	28.26										
	86	15	5.3	35.07										
	76	17	4.7	39.44										
	65	19	4.0	46.44										
	57	22	3.5	52.86										
	49	25	3.4	60.63										
	43	29	2.9	70.00										

*: Motore inclinato con portaspazzole a 45°
Motor assembly with brush holder inclined 45°

NOTA
Verificare sempre che la coppia M₂ utilizzata non ecceda il valore indicato nelle caselle in grigio

NOTE
Please check that the output torque M₂ does not exceed the value in the grey areas

NOTA: per servizio continuo o altamente intermittente, contattare il servizio tecnico
NOTE: for continuous or highly intermittent duty, please contact our technical service

ECFT

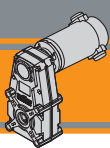

Dati tecnici

Technical data

P ₁ [W]	n ₂ [min ⁻¹]	M ₂ [Nm]	sf	i		Versione motore Motor version
250						
(3000 min ⁻¹)	60	37	4.6	50.10	180/176	24E*
	55	41	4.4	54.26		
	47	48	3.8	63.55		
	40	57	3.4	75.90		
	35	64	3.1	85.40		
	33	67	3.3	89.60		
	28	80	2.8	107.02		
	24	95	2.5	126.92		
	21	108	2.2	144.74		
	18	122	1.9	163.25		
	15	153	1.5	204.08		
	14	161	1.5	215.11		
	11	207	1.1	276.68		
	10	227	1.0	303.29		
	7.7	292	0.8	390.11		
	24	93	4.6	123.95	180/196	24E*
	19	118	3.6	158.02		
	15	151	2.8	201.80		
	11	202	2.1	269.47		

P ₁ [W]	n ₂ [min ⁻¹]	M ₂ [Nm]	sf	i		Versione motore Motor version
350						
(3000 min ⁻¹)	24	130	3.3	123.95	250/196	120/240 120.66/240.66
	19	165	2.6	158.02		
	15	211	2.0	201.80		
	11	282	1.5	269.47		

350						
P ₁ [W]	n ₂ [min ⁻¹]	M ₂ [Nm]	sf	i		Versione motore Motor version
(3000 min ⁻¹)	160	20	3.2	18.75	250/146	120/240 120.66/240.66
	131	24	2.6	22.89		
	115	27	2.3	26.17		
	106	30	2.1	28.26		
	86	37	2.1	35.07		
	76	41	1.9	39.44		
	65	49	1.6	46.44		
	57	55	1.4	52.86		
	49	64	1.4	60.63		
	43	73	1.2	70.00		
	41	78	1.1	74.02		
	35	89	1.0	84.63		
	31	100	0.9	95.61		
	26	119	0.7	113.40		
	207	15	7.2	14.49		
	173	18	6.5	17.31		
	143	22	5.7	20.97		
	122	26	5.5	24.56		
	102	31	4.6	29.33		
	87	36	4.1	34.62		
	80	39	3.8	37.50		
	73	43	3.6	41.35		
	67	47	3.5	44.79		
	60	52	3.3	50.10		
	55	57	3.2	54.26		
	47	67	2.7	63.55		
	40	79	2.5	75.90		
	35	89	2.2	85.40		
	33	94	2.3	89.60		
	28	112	2.0	107.02		
	24	133	1.8	126.92		
	21	152	1.5	144.74		
	18	171	1.4	163.25		
	15	214	1.1	204.08		
	14	225	1.0	215.11		
	11	290	0.8	276.68		
	10	318	0.7	303.29		

500								
P ₁ [W]	n ₂ [min ⁻¹]	M ₂ [Nm]	sf	i		Versione motore Motor version		
(3000 min ⁻¹)	160	28	2.2	18.75	350/146	120/240 120.66/240.66		
	131	34	1.8	22.89				
	115	39	1.6	26.17				
	106	42	1.5	28.26				
	86	52	1.5	35.07				
	76	59	1.3	39.44				
	65	69	1.1	46.44				
	57	79	1.0	52.86				
	49	91	0.9	60.63				
	43	105	0.8	70.00				
	41	111	0.8	74.02				
	207	22	5.0	14.49			350/176	120/240 120.66/240.66
	173	26	4.5	17.31				
	143	31	4.0	20.97				
	122	37	3.8	24.56				
	102	44	3.2	29.33				
	87	52	2.9	34.62				
	80	56	2.6	37.50				
	73	62	2.5	41.35				
	67	67	2.4	44.79				
	60	75	2.3	50.10				
	55	81	2.2	54.26				
	47	95	1.9	63.55				
	40	114	1.7	75.90				
	35	128	1.5	85.40				
	33	134	1.6	89.60				
	28	160	1.4	107.02				
	24	190	1.2	126.92				
	21	217	1.1	144.74				
	18	244	1.0	163.25				
	15	305	0.8	204.08				
	14	322	0.7	215.11				
	51	89	4.4	59.36	350/196	120/240 120.66/240.66		
	41	109	3.9	72.68				
	32	139	3.1	92.82				
	24	185	2.3	123.95				
	19	236	1.8	158.02				
	15	302	1.4	201.80				
	11	403	1.1	269.47				

800						
P ₁ [W]	n ₂ [min ⁻¹]	M ₂ [Nm]	sf	i		Versione motore Motor version
(3000 min ⁻¹)	160	45	1.4	18.75	600/146	120/240 120.66/240.66
	131	55	1.1	22.89		
	115	63	1.0	26.17		
	106	68	0.9	28.26		
	86	84	0.9	35.07		
	76	94	0.8	39.44		
	65	111	0.7	46.44		

*: Motore inclinato con portaspazzole a 45°

Motor assembly with brush holder inclined 45°

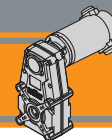

NOTA: per servizio continuo o altamente intermittente, contattare il servizio tecnico

NOTE: for continuous or highly intermittent duty, please contact our technical service



Dati tecnici

Technical data

P ₁ [W]	n ₂ [min ⁻¹]	M ₂ [Nm]	sf	i		Versione motore Motor version	P ₁ [W]	n ₂ [min ⁻¹]	M ₂ [Nm]	sf	i		Versione motore Motor version
800							800						
(3000 min ⁻¹)	207	35	3.1	14.49	600/176	120/240	(3000 min ⁻¹)	147	49	5.6	20.41	600/196	120/240
	173	41	2.8	17.31		120.66/240.66		86	83	3.7	34.81		120.66/240.66
	143	50	2.5	20.97				70	102	3.4	42.61		
	122	59	2.4	24.56				51	142	2.7	59.36		
	102	70	2.0	29.33				41	174	2.5	72.68		
	87	83	1.8	34.62				32	222	1.9	92.82		
	80	90	1.7	37.50				24	297	1.4	123.95		
	73	99	1.6	41.35				19	378	1.1	158.02		
	67	107	1.5	44.79				15	483	0.9	201.80		
	60	120	1.4	50.10									
	55	130	1.4	54.26									
	47	152	1.2	63.55									
	40	182	1.1	75.90									
	35	204	1.0	85.40									
	33	214	1.0	89.60									
	28	256	0.9	107.02									
	24	304	0.8	126.92									

Motori applicabili

Motor adapters

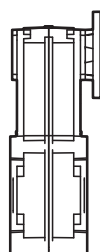
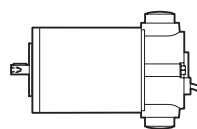

		EC						
		070.12E 070.24E	100.120 100.240 100.24E	180.120 180.240	180.24E	250.120 250.240	350.120 350.240	600.120 600.240
FT	105/3	20.57 - 315.05						
	105/4	368.19 - 929.4						
	146	18.75 - 397.38	* 18.75 - 397.38		18.75 - 397.38	18.75 - 397.38		
	176				* 14.49 - 390.11	14.49 - 390.11		
	196				* 20.41 - 269.47	20.41 - 269.47		

20.57 - 315.05

Rapporti di riduzione i
Ratio i

*: Motore inclinato con portaspazzole a 45°
Motor assembly with brush holder inclined 45°

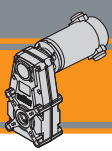

ECFT 070/105

ECFT 070/105...U

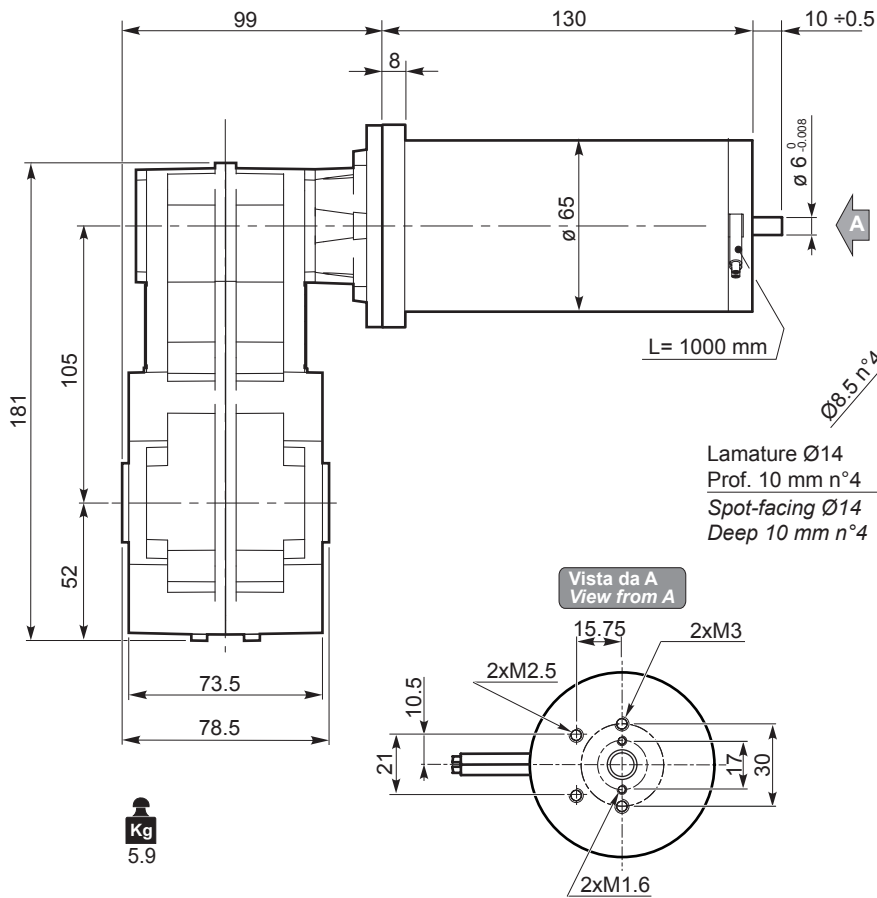

Kg
5.9

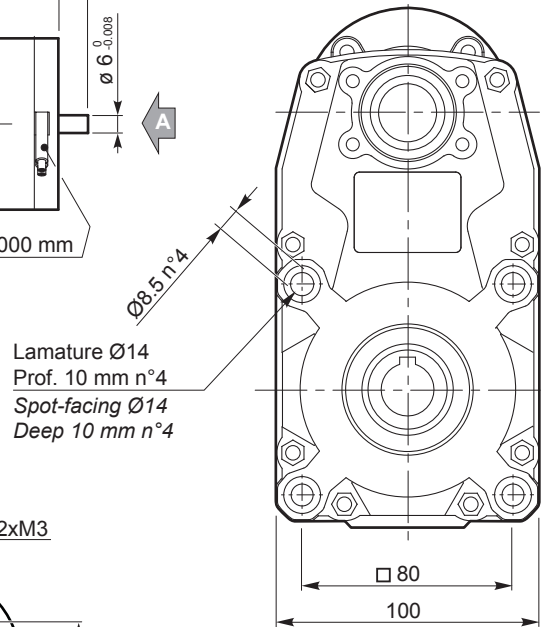

NOTA: Stessi fissaggi da entrambi i lati
NOTE: Same fixing points in both sides

Freno / Brake → **H23**

Encoder → **H24**

Motori / Motors IP66 → **I2**

O17

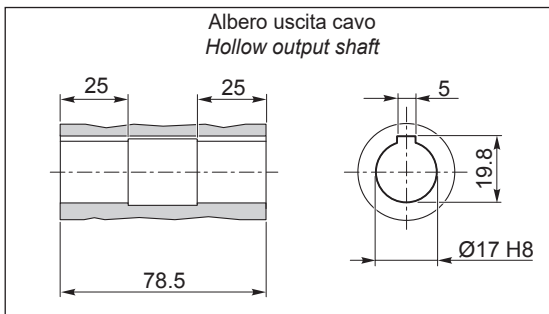

O20

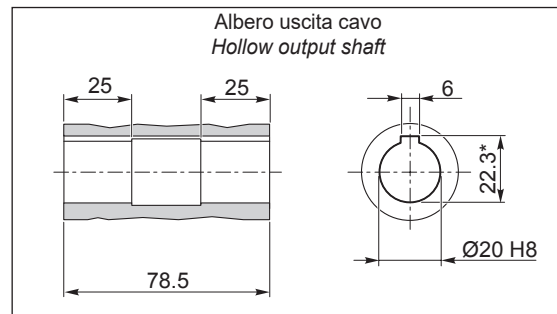

*: Sede linguetta ribassata / Special keyway

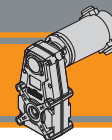

Dimensioni

Dimensions

ECFT 100/105

ECFT 100/105...U

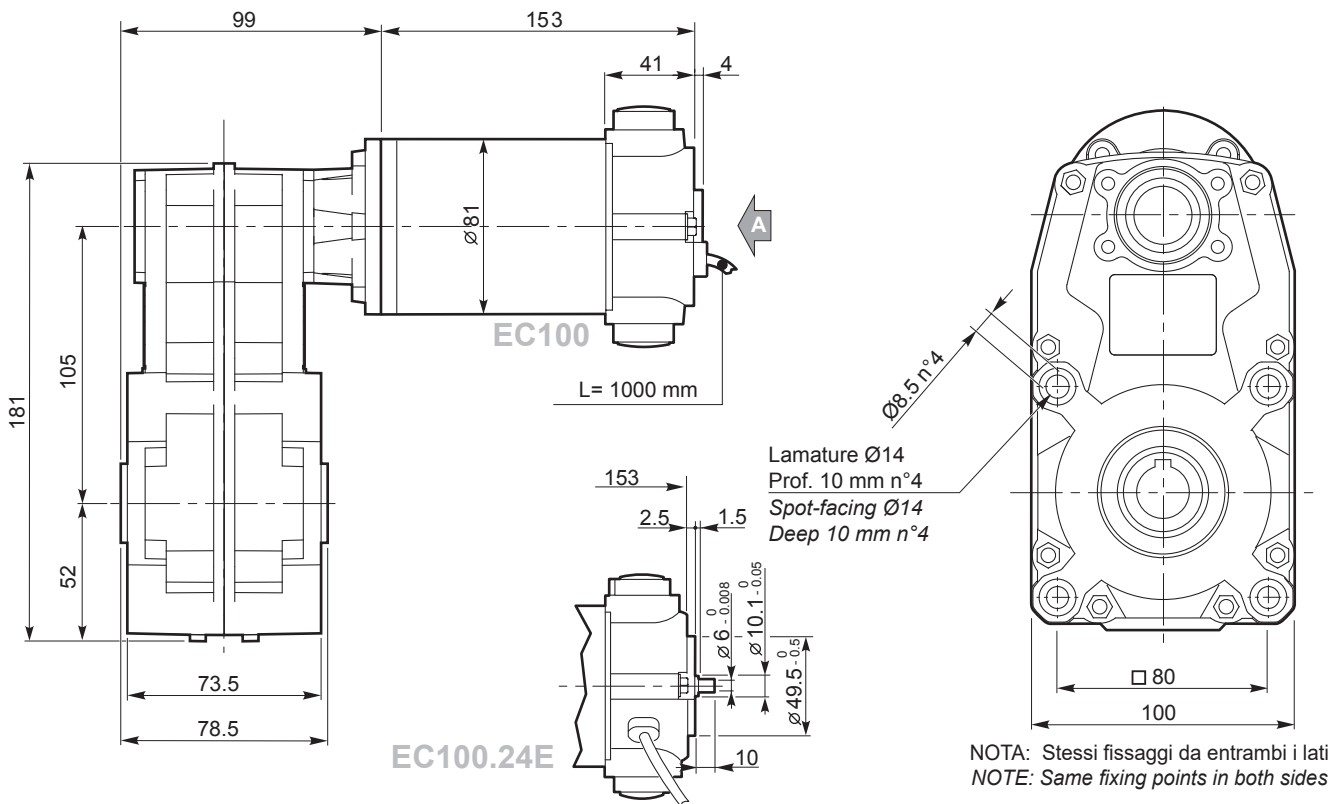

Kg
6.9

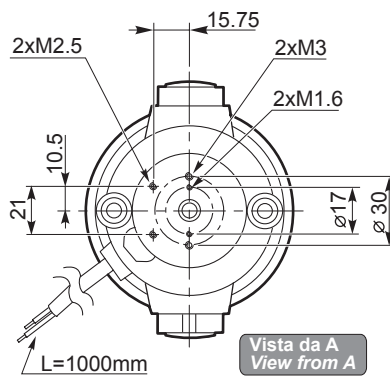

Freno / Brake → H23

Encoder → H24

Motori / Motors IP66 → I4

ECFT

O17

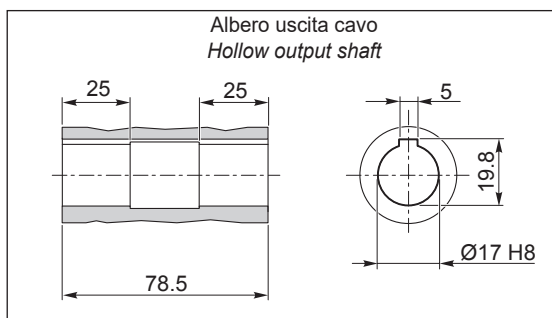

O20

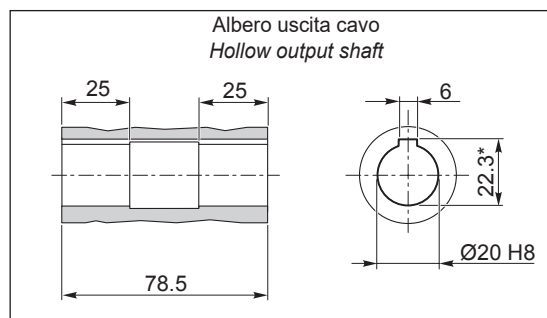

*: Sede linguetta ribassata / Special keyway

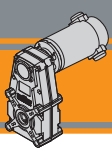

ECFT 180/105

ECFT 180/105...U

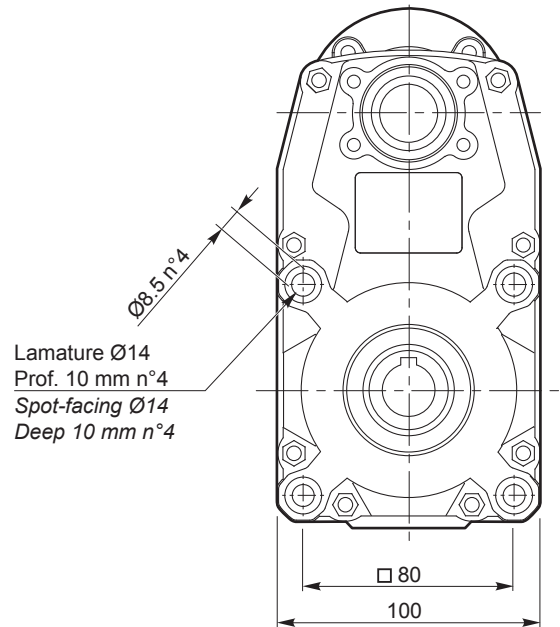
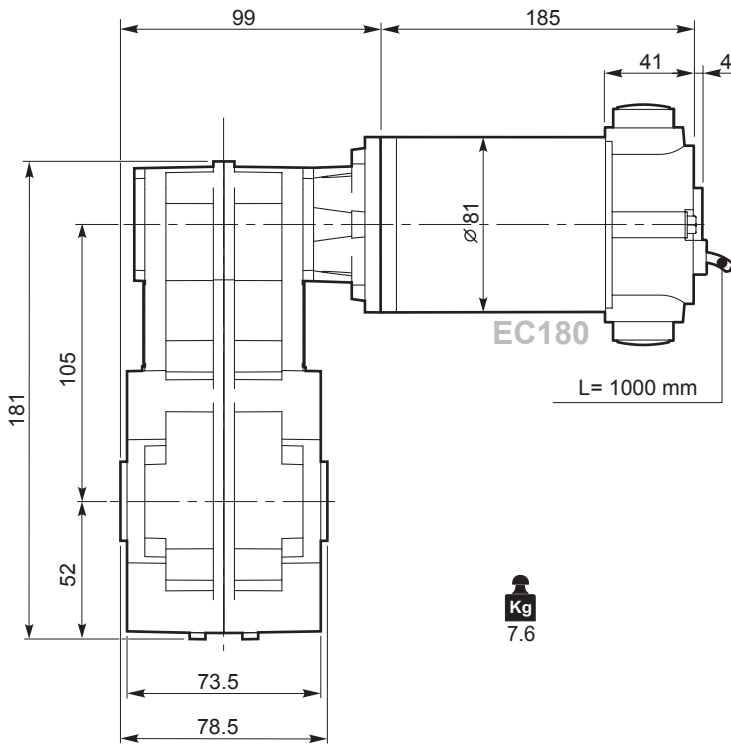

NOTA: Stessi fissaggi da entrambi i lati
NOTE: Same fixing points in both sides

Freno / Brake → H23

Encoder → H24

Motori / Motors IP66 → I6

O17

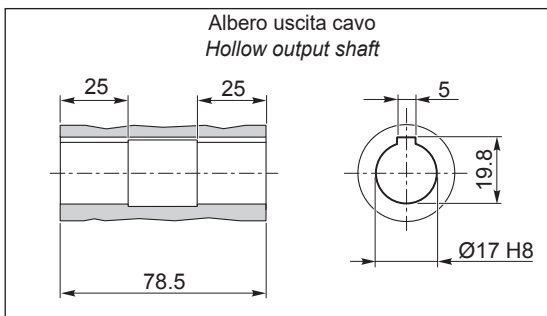

O20

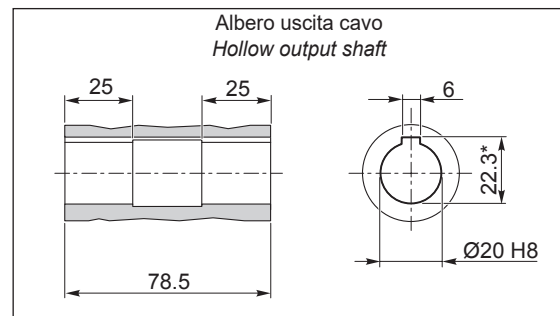

*: Sede linguetta ribassata / Special keyway

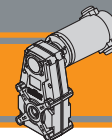

Dimensioni

Dimensions

ECFT 070/146

ECFT 070/146 U

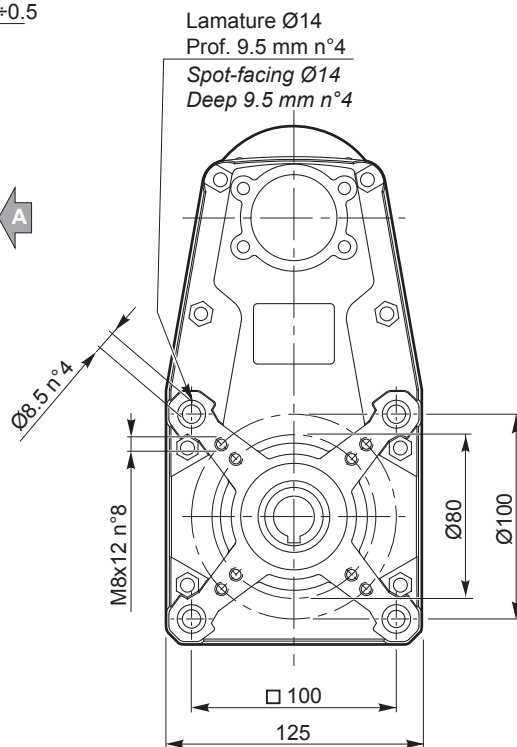
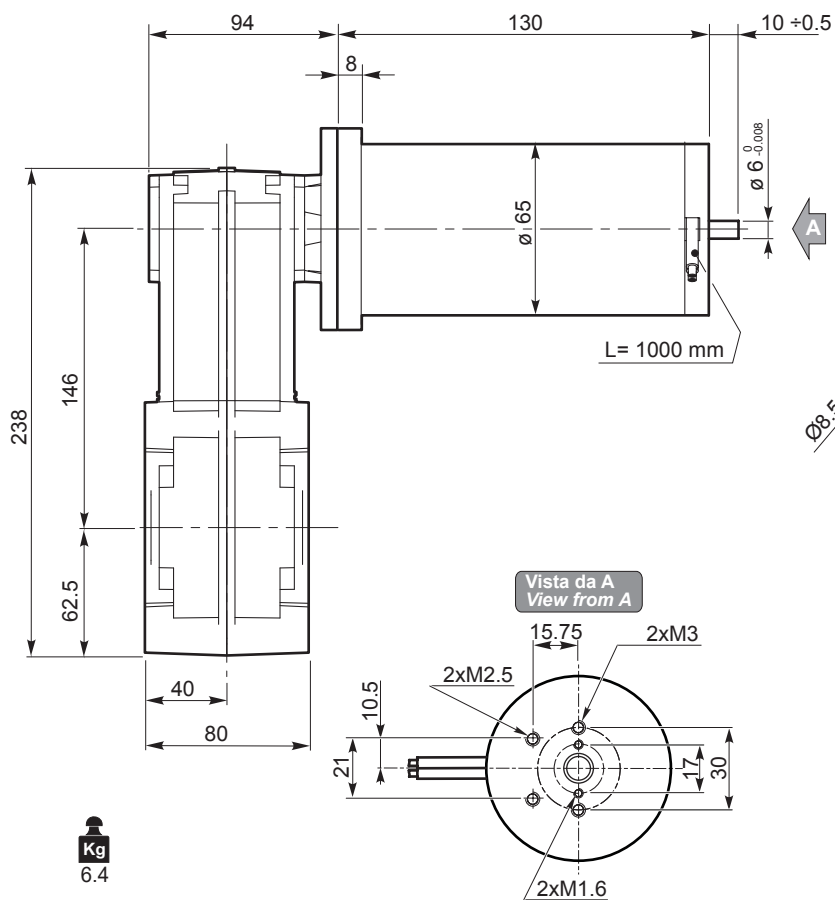

NOTA: Stessi fissaggi da entrambi i lati
NOTE: Same fixing points in both sides

Freno / Brake → H23

Encoder → H24

Motori / Motors IP66 → I2

ECFT

O20

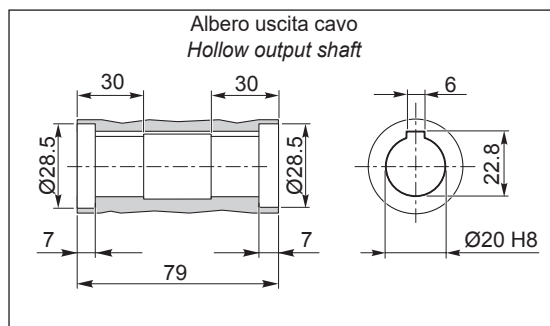

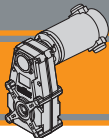

ECFT 100/146

ECFT 100/146 U

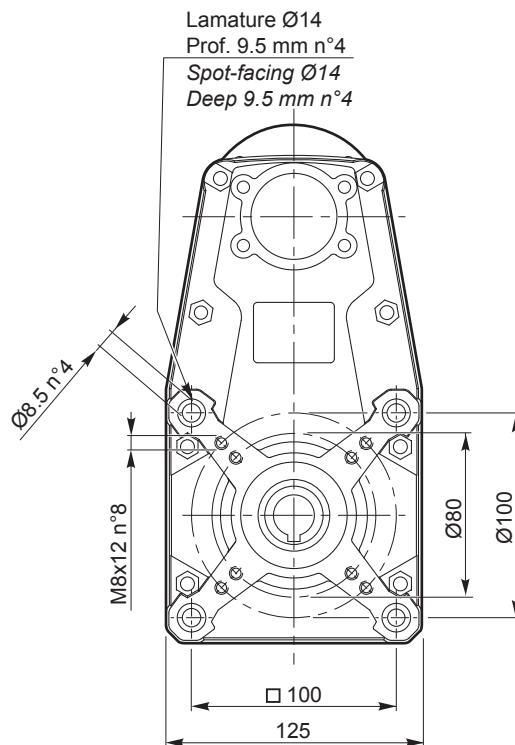
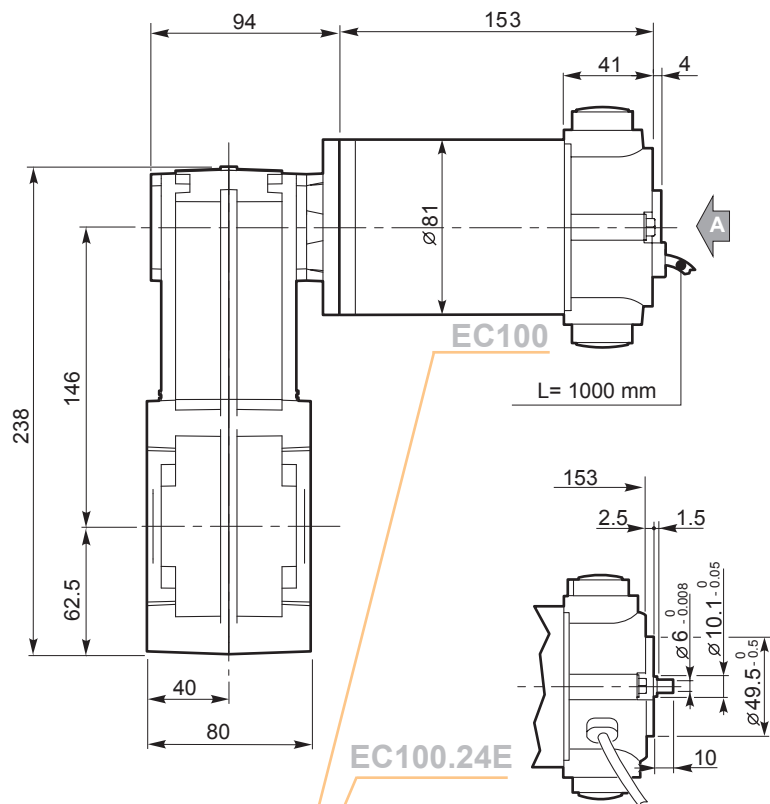

NOTA: Stessi fissaggi da entrambi i lati
NOTE: Same fixing points in both sides

Kg
7.4

Nota: Motore inclinato con portaspazzole a 45°
Note: Motor assembly with brush holder inclined 45°

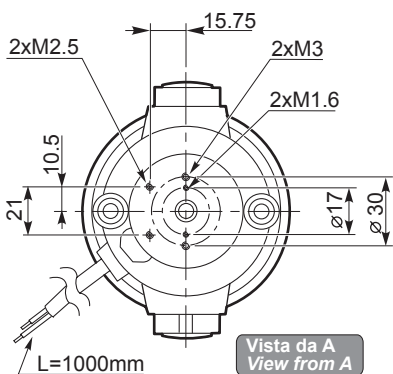

- Freno / Brake** → **H23**
- Encoder** → **H24**
- Motori / Motors IP66** → **I4**

O20

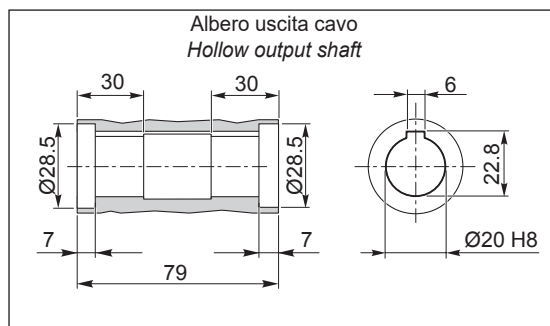

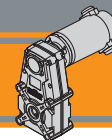

Dimensioni

Dimensions

ECFT 180/146

ECFT 180/146 U

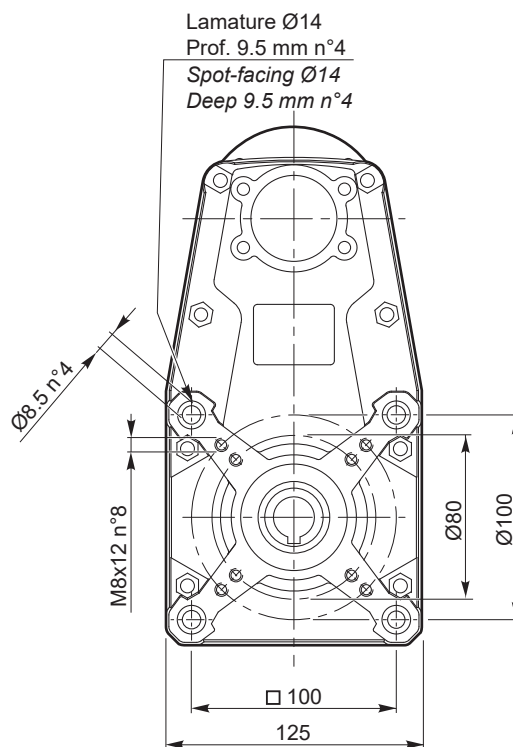
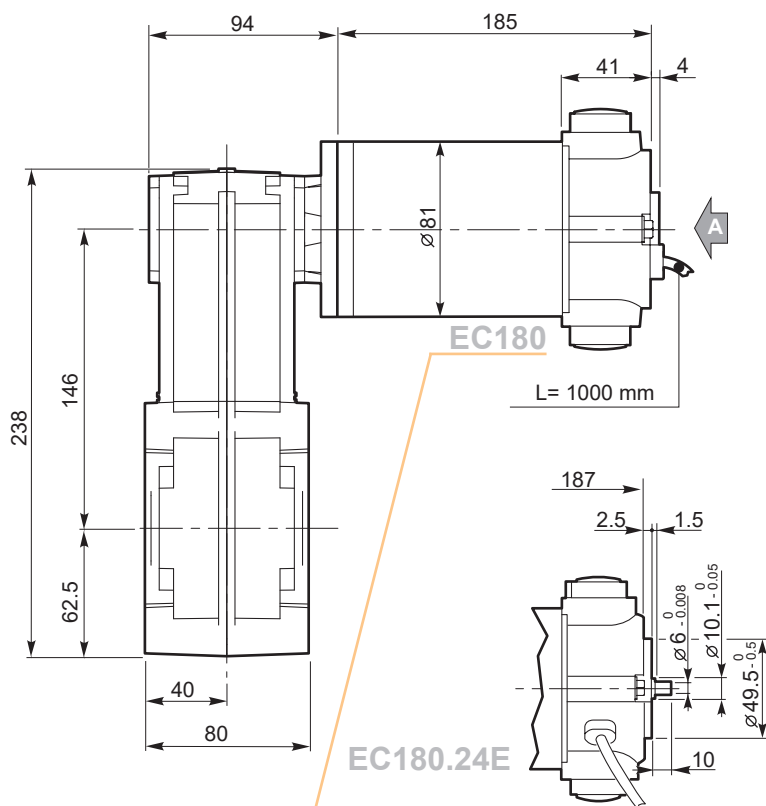

NOTA: Stessi fissaggi da entrambi i lati
NOTE: Same fixing points in both sides

8.1

Nota: Motore inclinato con portaspazzole a 45°
Note: Motor assembly with brush holder inclined 45°

- Freno / Brake → H23
- Encoder → H24
- Motori / Motors IP66 → I6

ECFT

O20

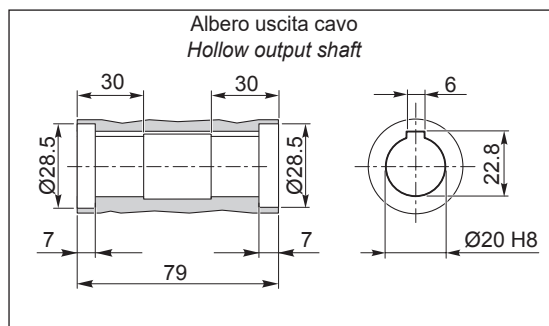

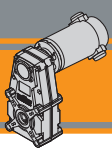

Dimensioni

Dimensions

ECFT 250/146

ECFT 250/146 U

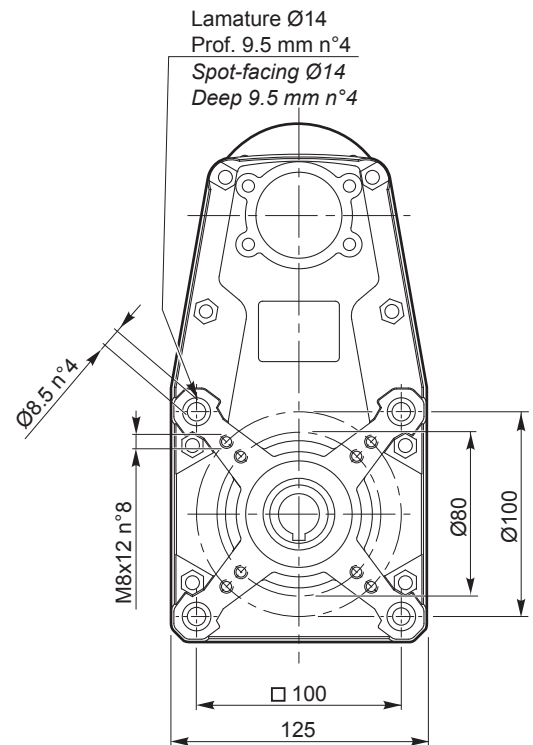
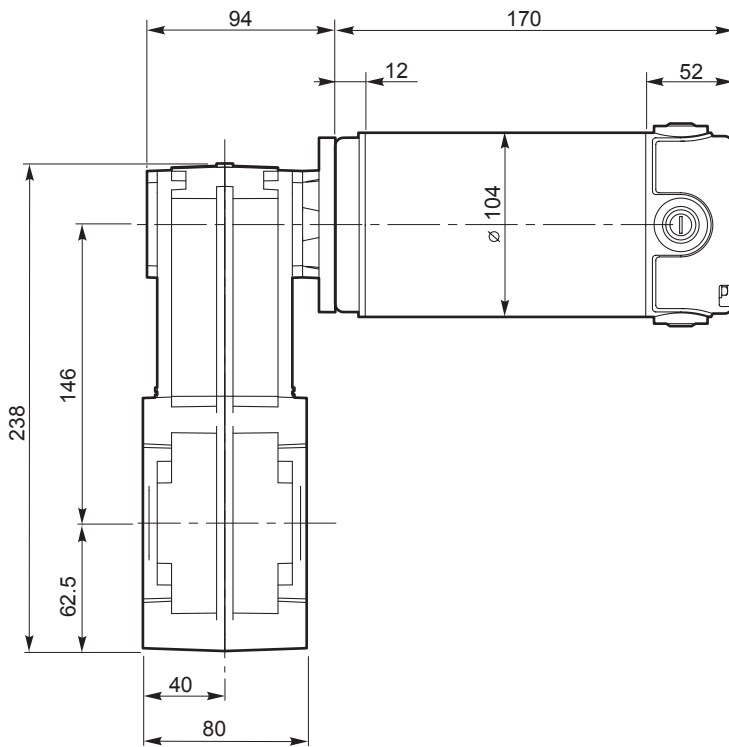

Kg
8.9

NOTA: Stessi fissaggi da entrambi i lati
NOTE: Same fixing points in both sides

Motori / Motors IP66

18

O20

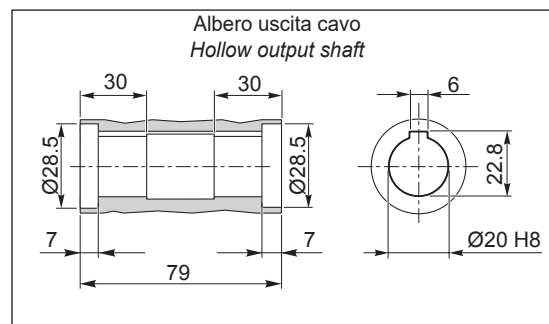

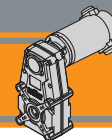

Dimensioni

Dimensions

ECFT 350/146

ECFT 350/146 U

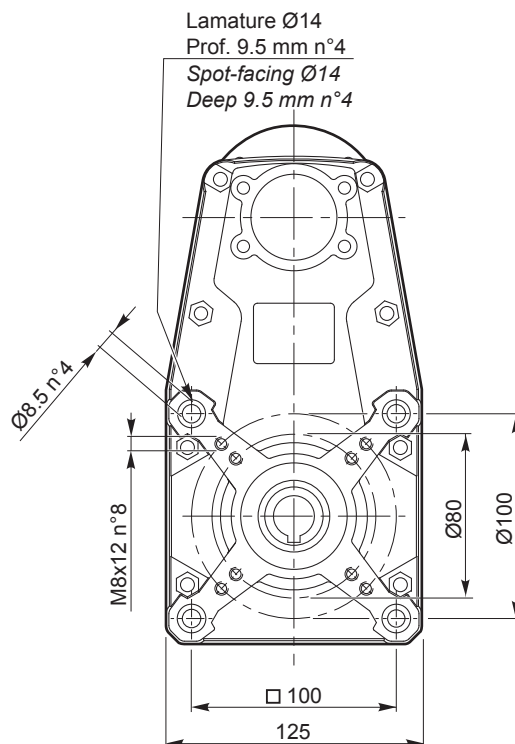
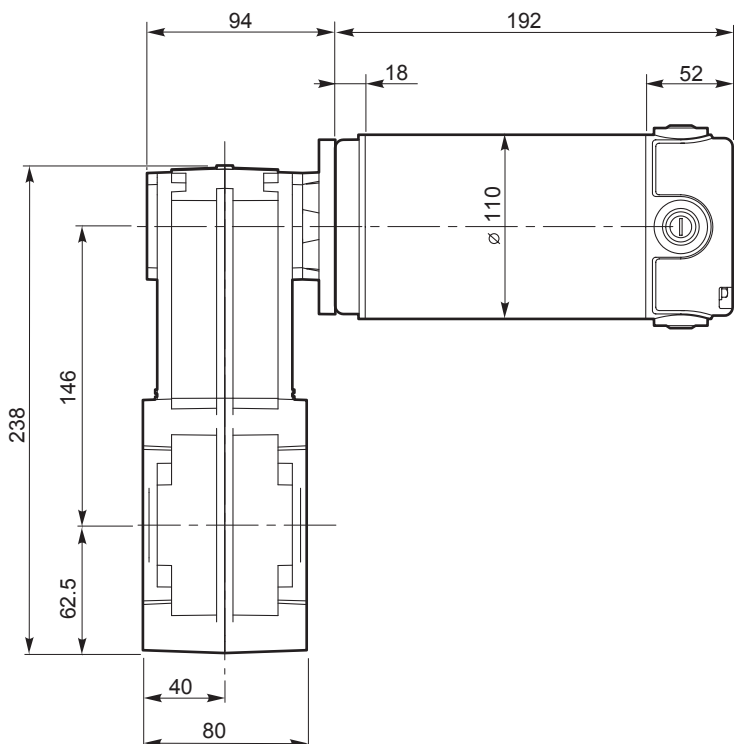

NOTA: Stessi fissaggi da entrambi i lati
NOTE: Same fixing points in both sides

Kg
10.0

Freno / Brake → H23

Motori / Motors IP66 → I10

ECFT

O20

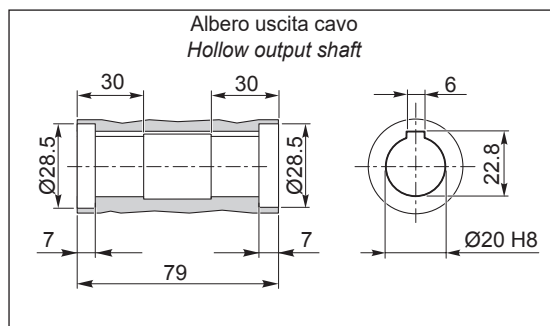

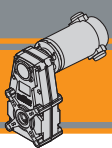

ECFT 600/146

ECFT 600/146 U

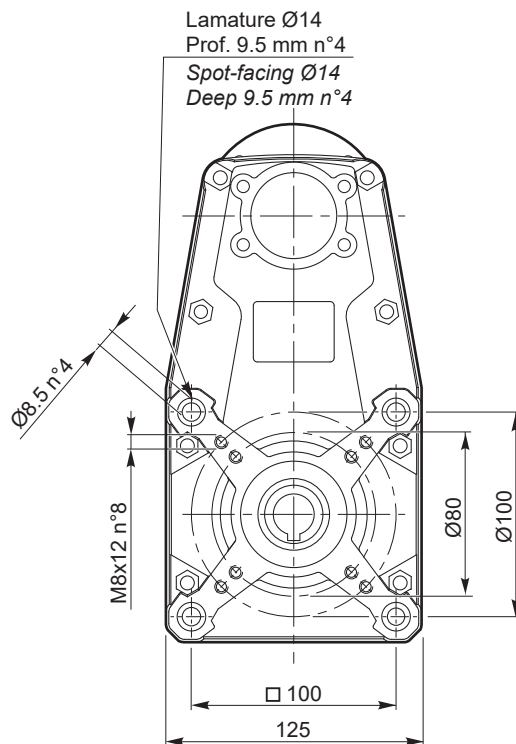
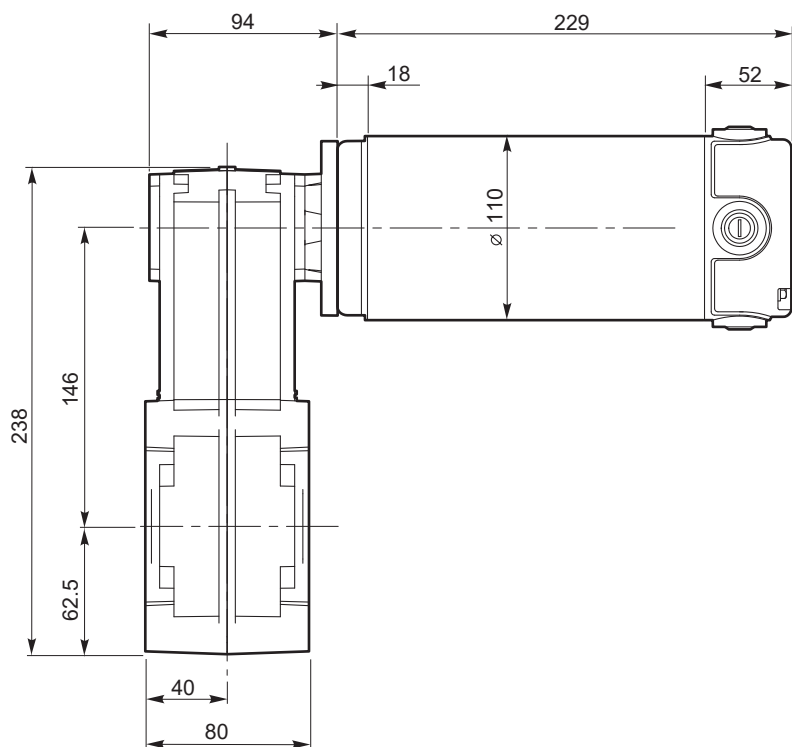

Kg
11.8

NOTA: Stessi fissaggi da entrambi i lati
NOTE: Same fixing points in both sides

Freno / Brake → **H23**

Motori / Motors IP66 → **I10**

O20

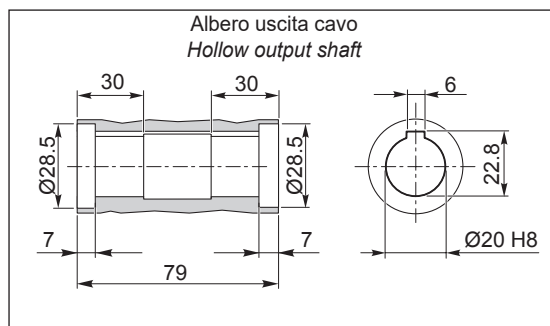

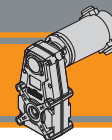

Dimensioni

Dimensions

ECFT 180/176.24E

ECFT 180/176.24E U

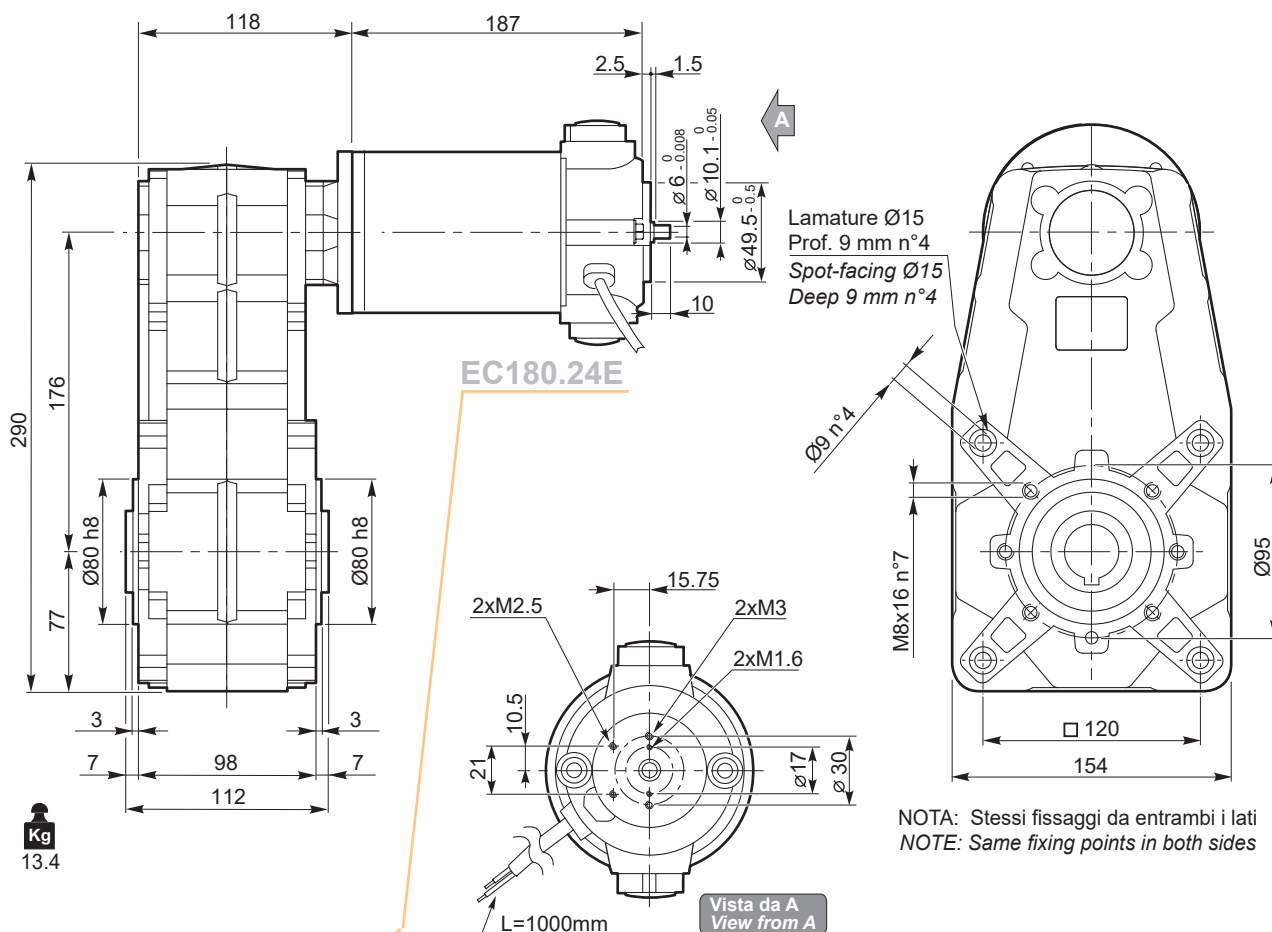

Nota: Motore inclinato con portaspazzole a 45°
Note: Motor assembly with brush holder inclined 45°

Encoder

H24

ECFT

O25

Albero uscita cavo
Hollow output shaft

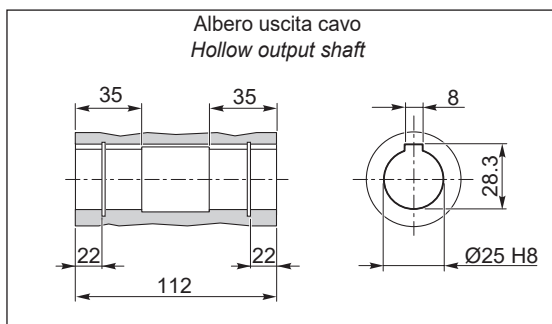

O30

Albero uscita cavo
Hollow output shaft

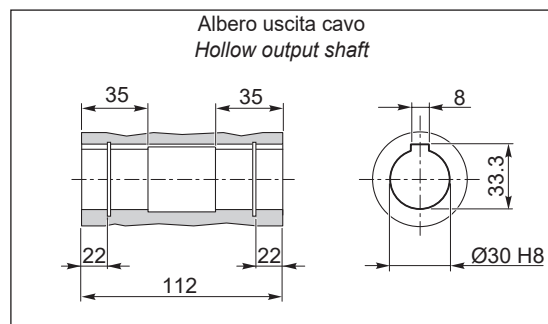

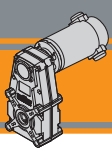

ECFT 250/176

ECFT 250/176 U

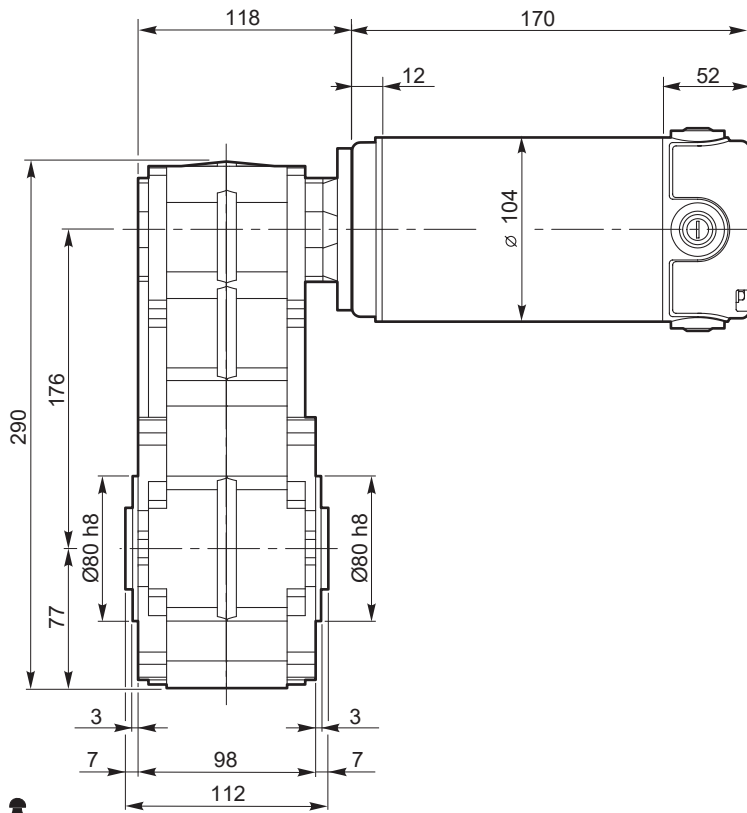

Lamature Ø15
Prof. 9 mm n°4
Spot-facing Ø15
Deep 9 mm n°4

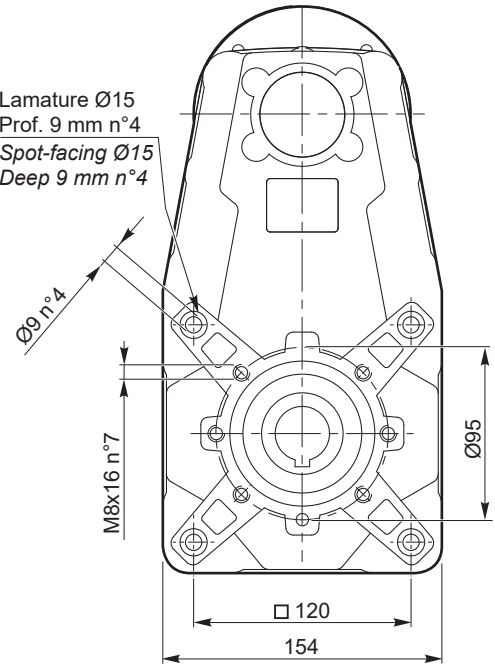

Kg
14.2

Motori / Motors IP66

110

O25

Albero uscita cavo
Hollow output shaft

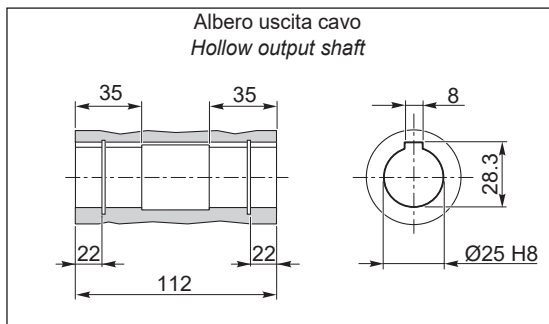

O30

Albero uscita cavo
Hollow output shaft

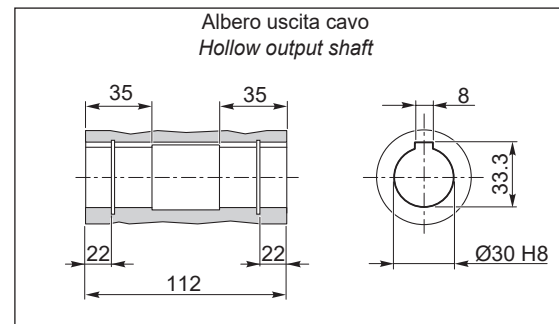

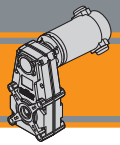

Dimensioni

Dimensions

ECFT 350/176

ECFT 350/176 U

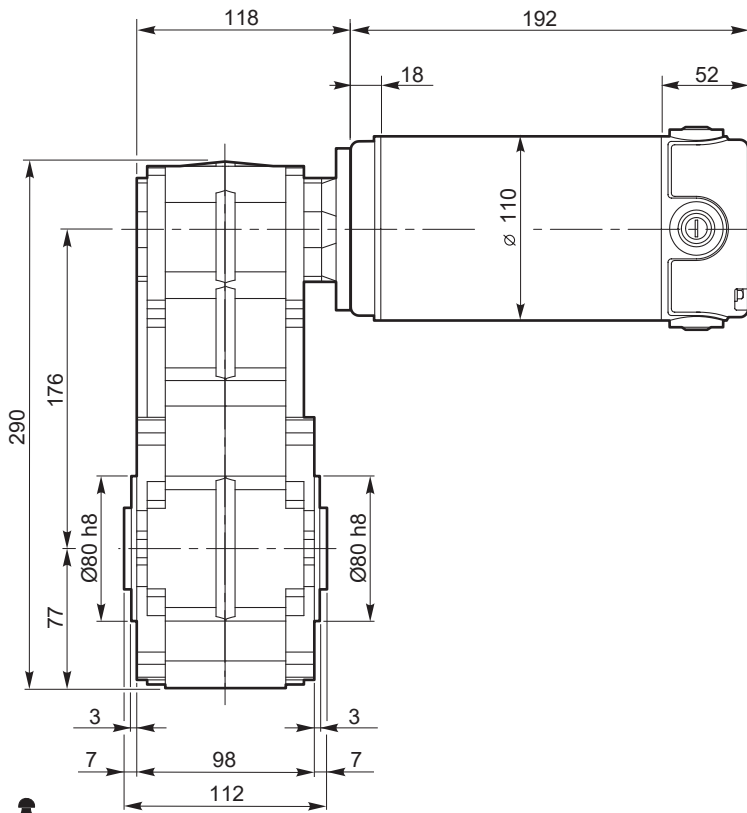

Lamature Ø15
Prof. 9 mm n°4
Spot-facing Ø15
Deep 9 mm n°4

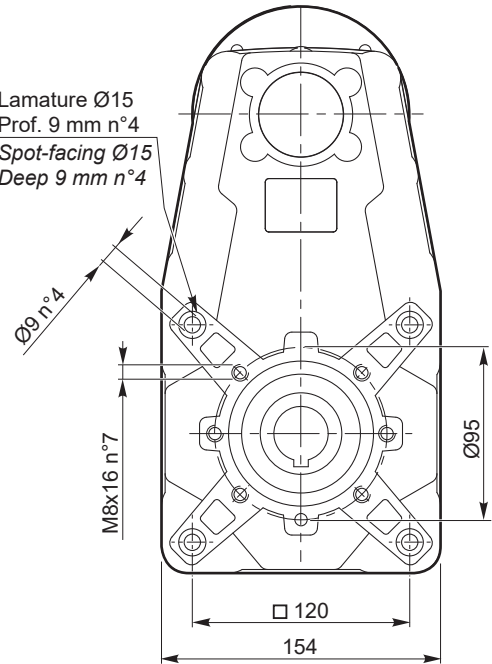

Kg
15.3

Freno / Brake

H23

Motori / Motors IP66

I10

ECFT

O25

Albero uscita cavo
Hollow output shaft

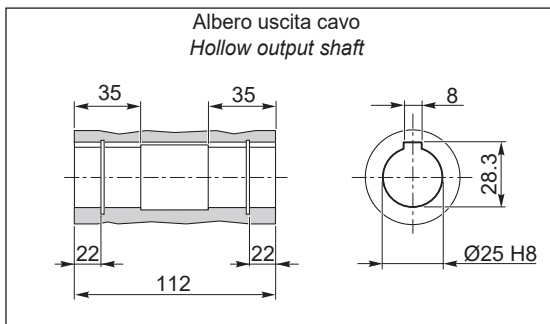

O30

Albero uscita cavo
Hollow output shaft

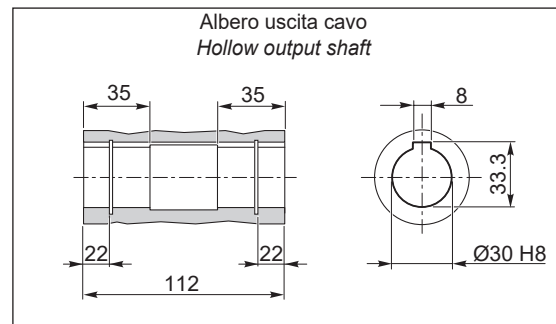

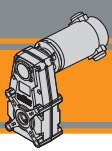

Dimensioni

Dimensions

ECFT 600/176

ECFT 600/176 U

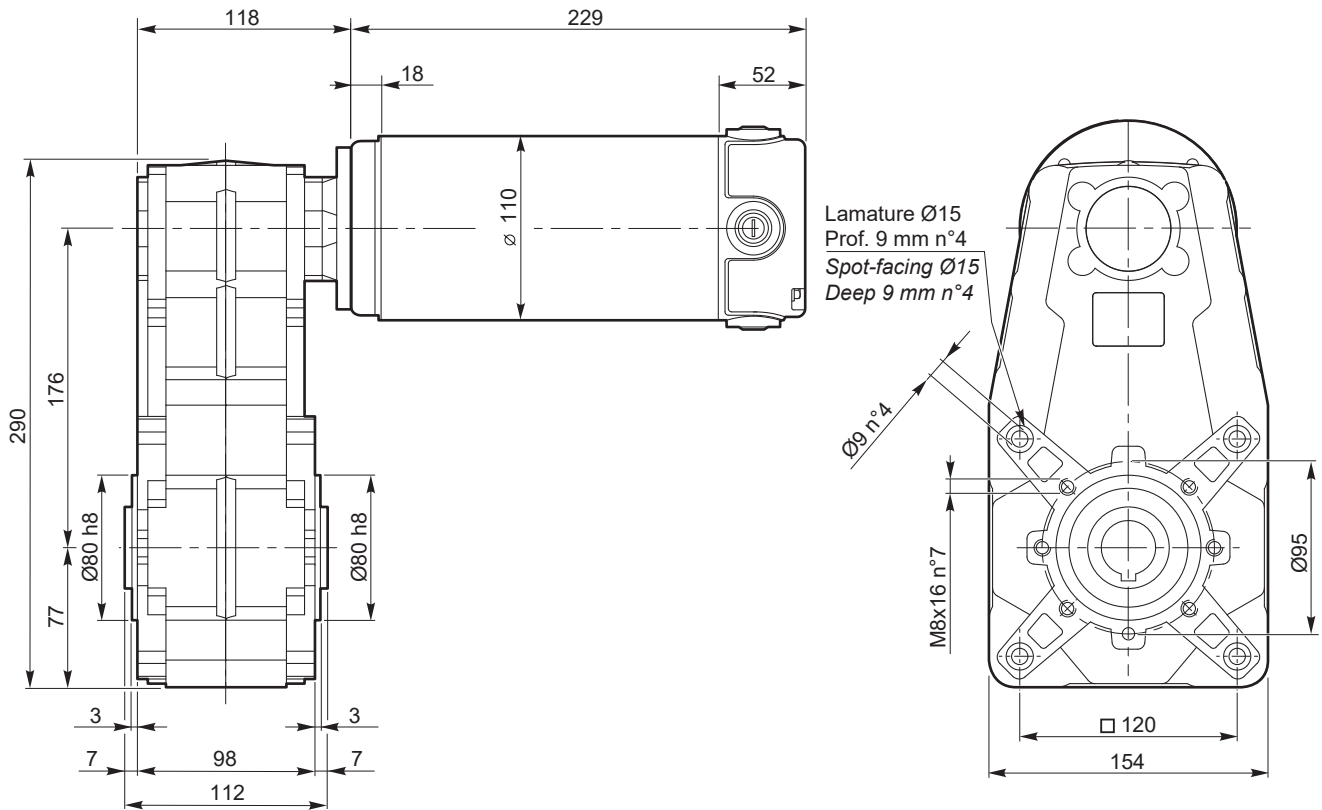

Kg
17.1

Freno / Brake → **H23**

Motori / Motors IP66 → **I10**

O25

Albero uscita cavo
Hollow output shaft

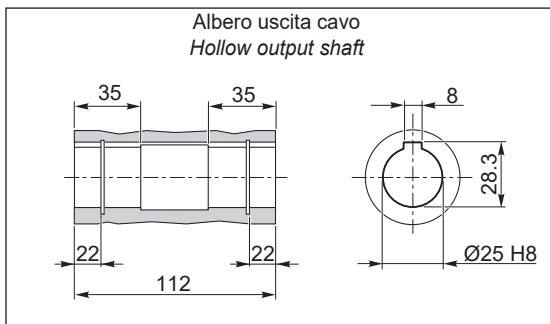

O30

Albero uscita cavo
Hollow output shaft

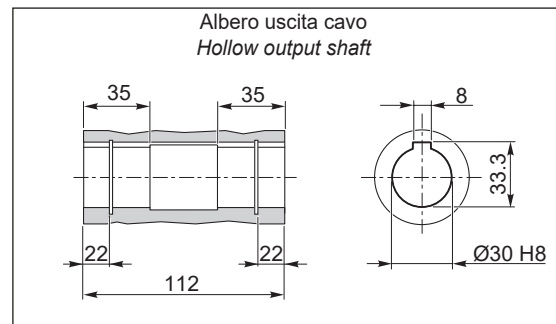

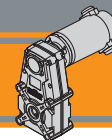

Dimensioni

Dimensions

ECFT 180/196.24E

ECFT 180/196.24E U

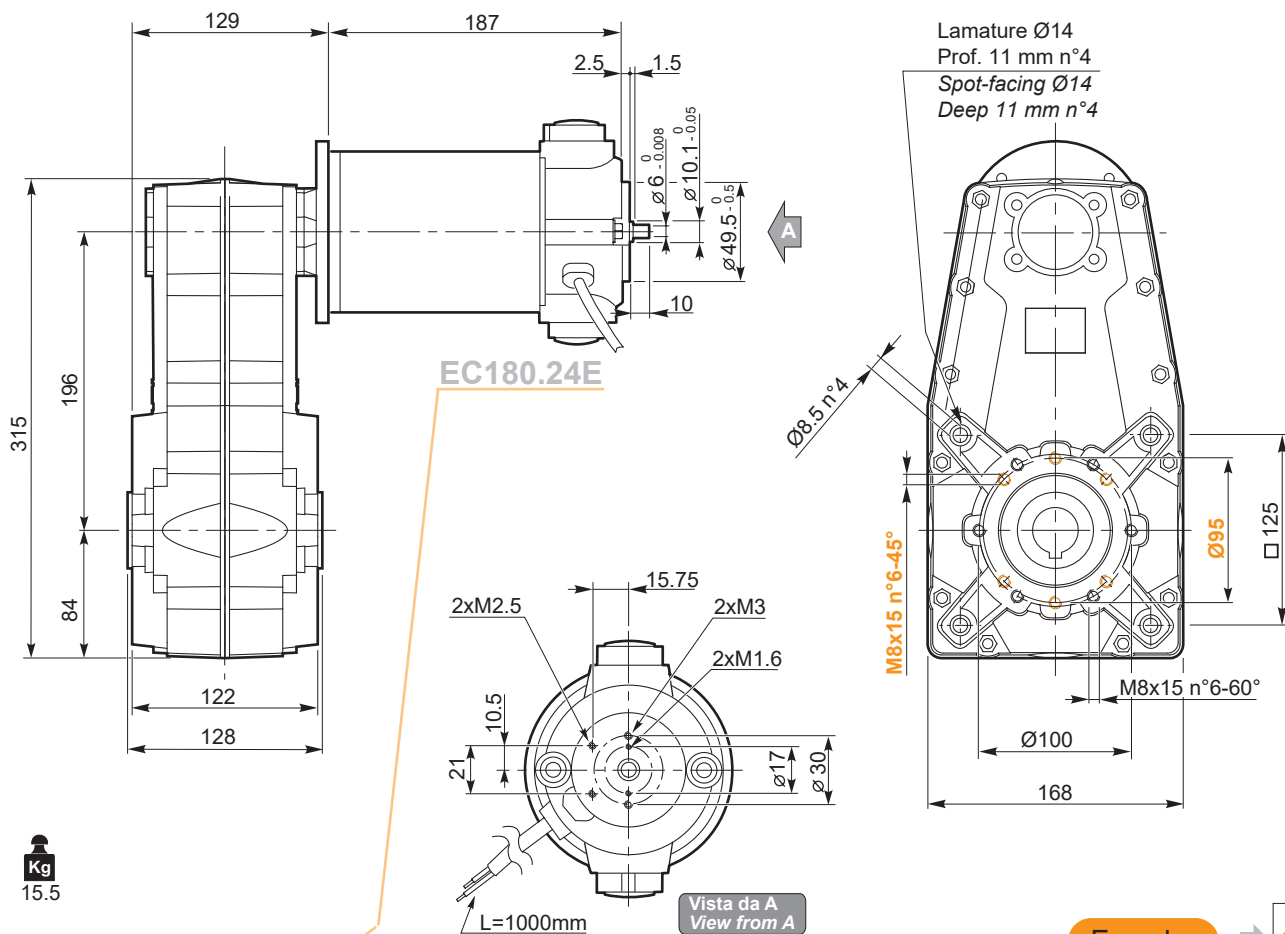

Nota: Motore inclinato con portaspazzole a 45°
Note: Motor assembly with brush holder inclined 45°

Encoder → H24

O30

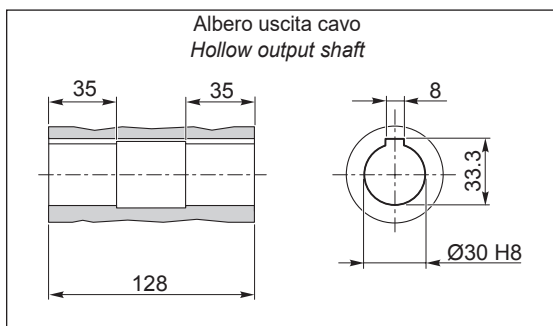

O35

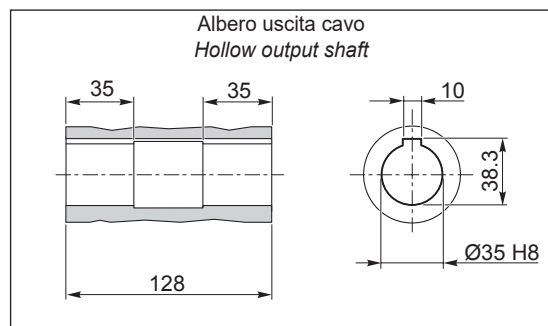

ECFT

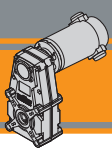

ECFT 250/196

ECFT 250/196 U

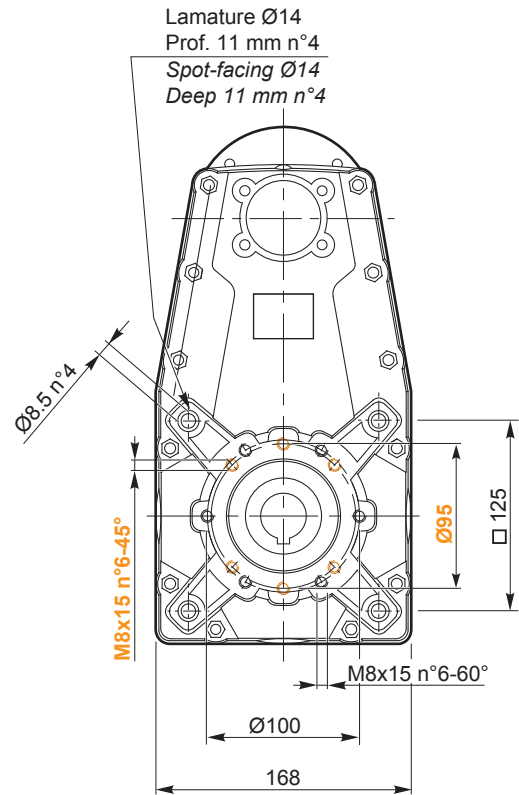
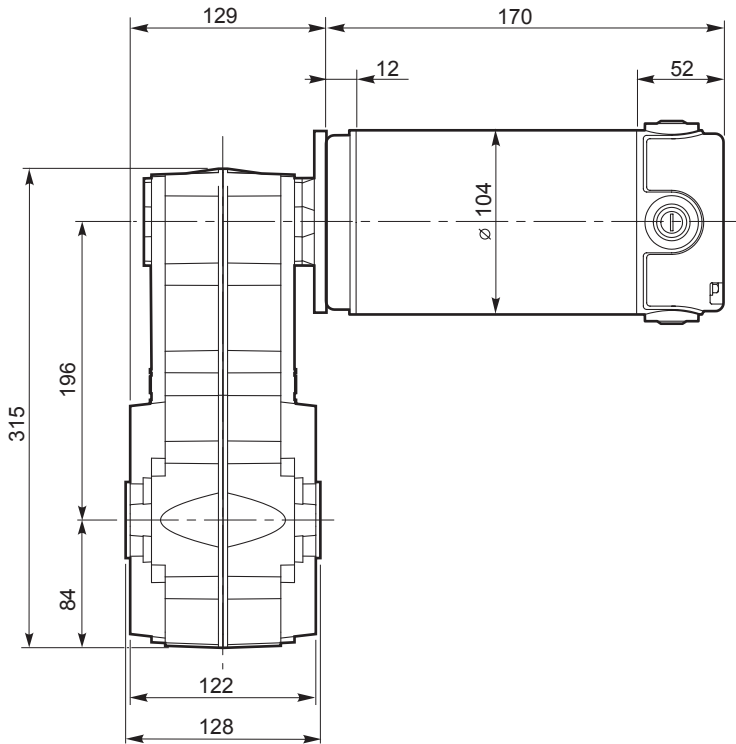

Kg
16.3

NOTA: Stessi fissaggi da entrambi i lati
NOTE: Same fixing points in both sides

Motori / Motors IP66

18

O30

Albero uscita cavo
Hollow output shaft

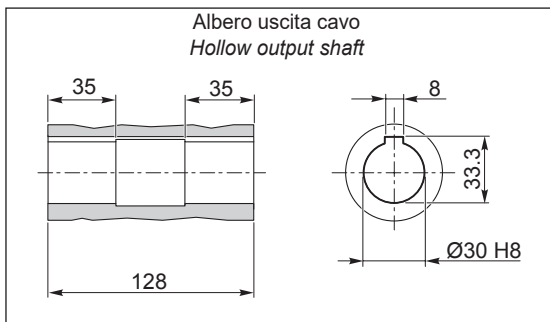

O35

Albero uscita cavo
Hollow output shaft

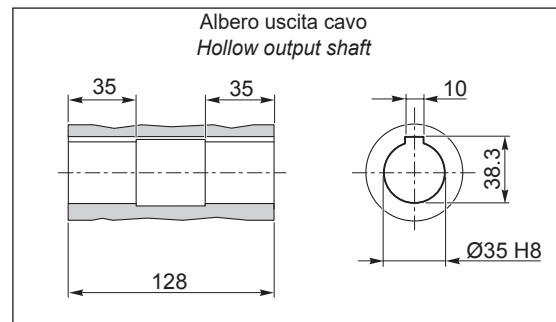

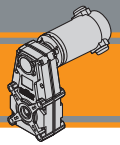

Dimensioni

Dimensions

ECFT 350/196

ECFT 350/196 U

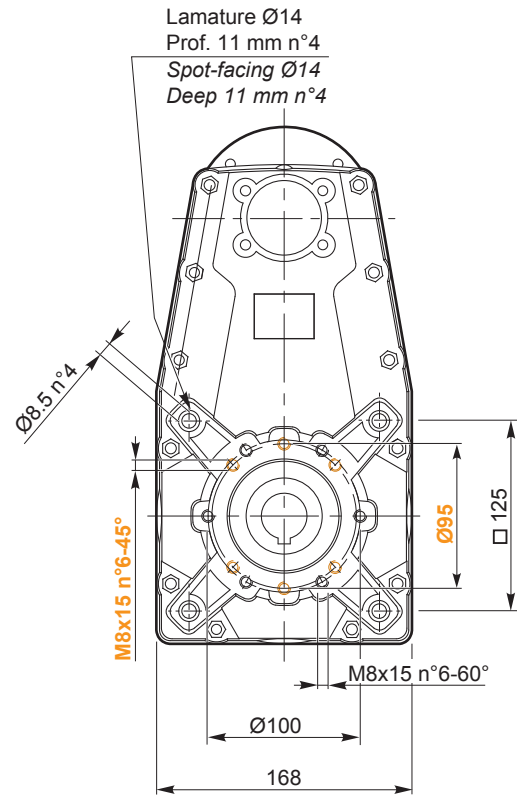
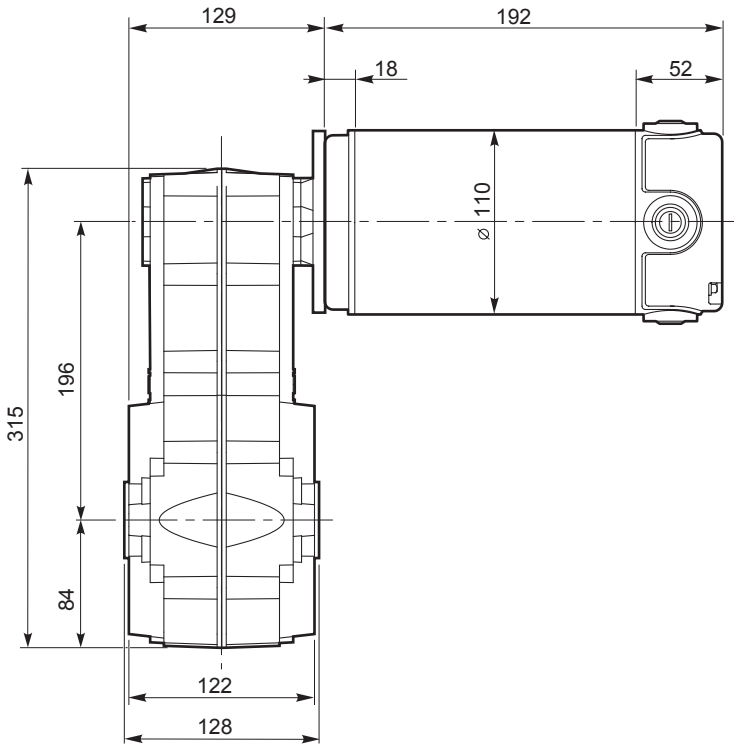

Kg
17.4

NOTA: Stessi fissaggi da entrambi i lati
NOTE: Same fixing points in both sides

Freno / Brake

H23

Motori / Motors IP66

I10

ECFT

O30

Albero uscita cavo
Hollow output shaft

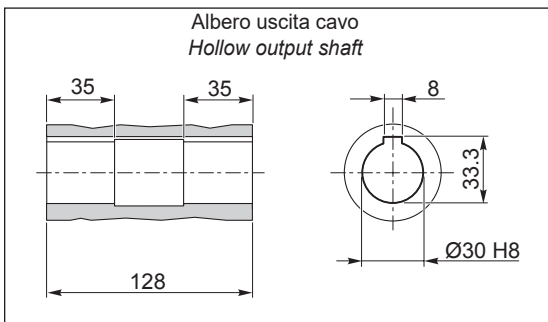

O35

Albero uscita cavo
Hollow output shaft

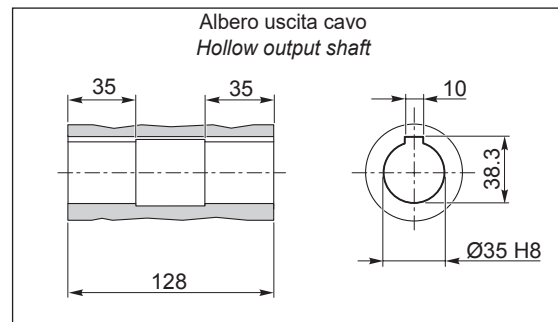

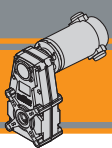

ECFT 600/196

ECFT 600/196 U

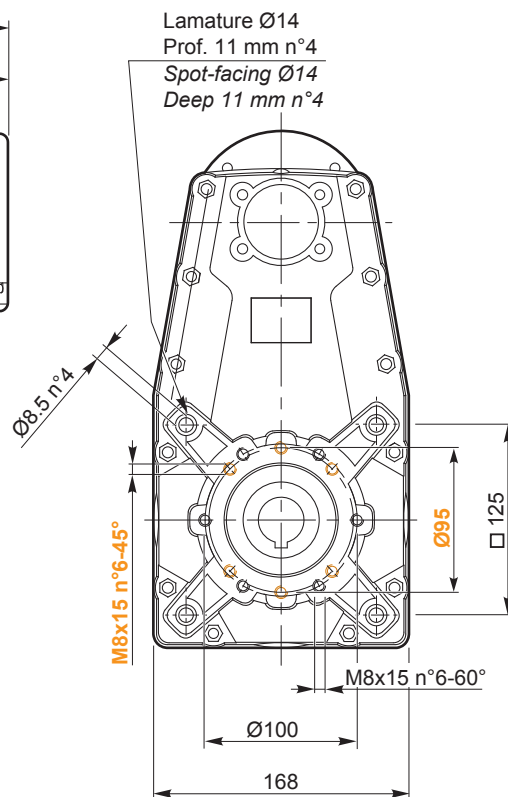
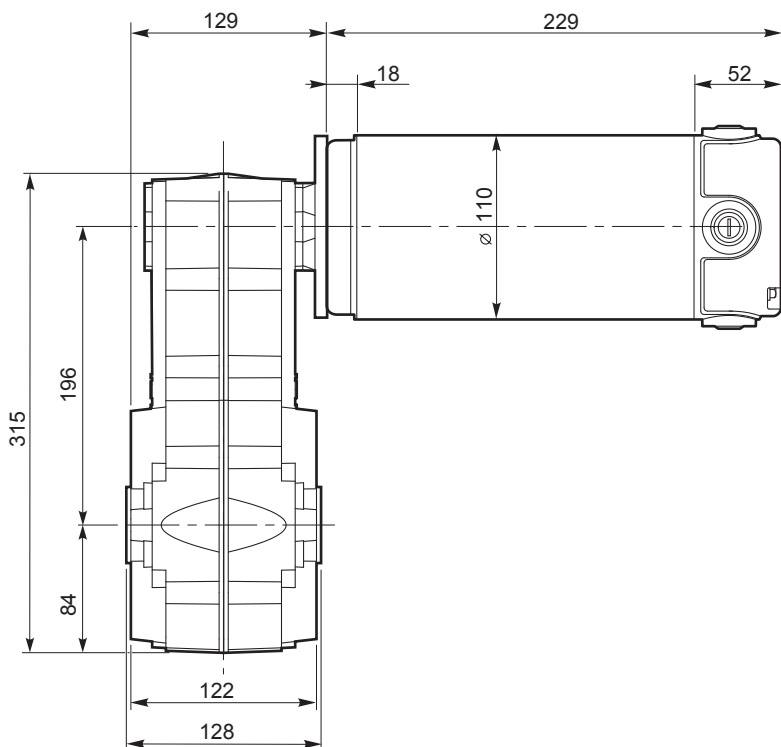

Kg
19.2

NOTA: Stessi fissaggi da entrambi i lati
NOTE: Same fixing points in both sides

Freno / Brake

H23

Motori / Motors IP66

I12

O30

Albero uscita cavo
Hollow output shaft

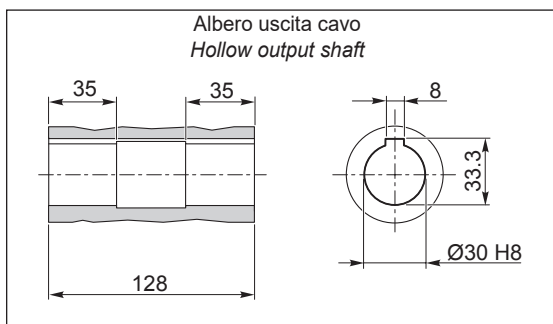

O35

Albero uscita cavo
Hollow output shaft

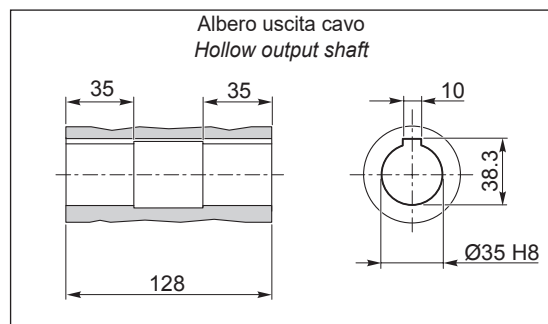

 **TRANSTECNO SRL**
HEADQUARTERS

Company subject to the management
and coordination of INTERPUMP GROUP SPA
Via Caduti di Sabbiuno, 11/D-E
40011 Anzola dell'Emilia (BO)
ITALY
T+39 051 64 25 811
F +39 051 73 49 43
sales@transtecno.com
www.transtecno.com

the modular gearmotor
MEMBER OF INTERPUMP GROUP



 **HANGZHOU INTERPUMP
POWER TRANSMISSIONS CO LTD**
No.4 Xiuyan Road Fengdu Industry Zone
Pingyao Town Yuhang District
Hangzhou City, Zhejiang Province
311115 – CHINA
T +86 571 86 92 02 60
info-china@transtecno.cn
www.transtecno.cn

 **TRANSTECNO IBÉRICA
THE MODULAR GEARMOTOR, S.A.**
Carrer de la Ciència, 45
08840 Viladecans (Barcelona) - SPAIN
T +34 931 598 950
info@transtecno.es
www.transtecno.es

 **TRANSTECNO B.V.**
Siliciumweg 32
3812 SX Amersfoort - NETHERLANDS
T +31(0) 33 45 19 505
info@transtecno.nl
www.transtecno.nl

 **TRANSTECNO AANDRIJFTECHNIEK B.V.**
Siliciumweg 32
3812 SX Amersfoort - NETHERLANDS
T +31 (0) 33 20 47 006
info@transtecnoaandrijftechniek.nl
www.transtecnoaandrijftechniek.nl

 **MA TRANSTECNO S.A.P.I. DE C.V.**
Julián Sepúlveda Dávila #107,
Parque Industrial SG
Apodaca, Nuevo León, CP. 66640
MÉXICO
T +52 8113340920
info@transtecno.com.mx
www.transtecno.com.mx

 **TRANSTECNO USA**
8 Creek Parkway,
Boothwyn PA 19061-8136 - UNITED STATES
T + 1 (610) 4970154

TRANSTECNO USA – WEST COAST BRANCH
14561 Fryelands Blvd SE
Monroe, WA 98272 - UNITED STATES
T +1 360-863-1300
usaoffice@transtecno.com
www.transtecno.com

 **TRANSTECNO CANADA**
51 B Caldari Road Unit 10
Vaughan, ON L4K 4G3 - CANADA
T +1 905 761 0762
canadaoffice@transtecno.com
www.transtecno.com

 **TRANSTECNO INDIA**
#6A, Sipcot Industrial complex, Phase-1,Elasagiri Road
Hosur – 635126 Tamilnadu - INDIA
T +91 4344 274434
M +91 81443 88800

TRANSTECNO INDIA – NORTH BRANCH
Plot No: 3 A, Sector 2, IIE, Sidcul, Pantnagar
U.S. Nagar, Uttarakhand – 263153 - INDIA
indiaoffice@transtecno.com
www.transtecno.com

 **TRANSTECNO BRAZIL**
Rua Gilberto de Zorzi, 525 Forqueta - CEP. 95115-730
CX Postal 3544 Caxias do Sul RS – BRAZIL

TRANSTECNO BRAZIL – SÃO PAULO BRANCH
R. Mafalda Barnabe Soliane, 314 – CEP. 13347-610
Indaiatuba, São Paulo - BRAZIL
T +55 19 3437 2520

TRANSTECNO BRAZIL – PORTO ALEGRE BRANCH
Rua Dr. Freire Alemão 155 / 402 - CEP. 90450-060
Auxiliadora Porto Alegre RS - BRAZIL
T +55 51 4042 0916
M +55 51 811 45 962
braziloffice@transtecno.com
www.transtecno.com.br

 **INTERPUMP ANTRIEBSTECHNIK GMBH**
Büro Stuttgart - GERMANY
T +49 (0)171 4781909
germanoffice@transtecno.com
www.transtecno.com

 **SALES OFFICE OCEANIA**
Unit 5, 12 Nyholt Drive, Yatala 4207
Queensland - AUSTRALIA
T +61 07 3800 0103
M +61 04 38060997

UNIT 9, 94 Boundary Rd, Sunshine West 3020
Victoria - AUSTRALIA
T +61 9312 4722
oceaniaoffice@transtecno.com
www.transtecno.com.au