

TRANSTECNO[®]
the modular gearmotor

CMM



60Hz

Nema

Motorreductores sinfín corona
de doble reducción
Double reduction wormgearmotors



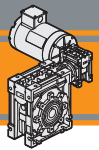

Índice	Index	Pág. Page
Características técnicas	<i>Technical features</i>	E2
Clasificación	<i>Classification</i>	E2
Nomenclatura	<i>Symbols</i>	E3
Ejecución de montaje	<i>Mounting executions</i>	E3
Relaciones combinadas	<i>Combination ratio</i>	E3
Lubricación	<i>Lubrication</i>	E3
Datos técnicos	<i>Technical data</i>	E4
Motores aplicables	<i>IEC Motor adapters</i>	E6
Dimensiones	<i>Dimensions</i>	E7
Accesorios	<i>Accessories</i>	E10
Opciones	<i>Options</i>	E11

Esta sección substituye y anula las ediciones y revisiones previas. Si usted obtiene este catálogo a través de canales de distribución no autorizados o fuera de nuestro control, la versión en vigor no estará garantizada. **En todo caso, la versión más actualizada está disponible en nuestra página de internet www.transtecno.com**

*This section replaces any previous edition and revision. If you obtained this catalogue other than through controlled distribution channels, the most up to date content is not guaranteed. **In this case the latest version is available on our web site www.transtecno.com***

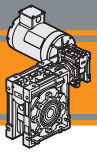

Características técnicas

Technical features

El rango de combinación de los reductores CMM tienen las siguientes características principales:

CMM range double reduction worm-worm gearboxes have the following main features:

- Caja de aluminio para tamaños 040, 050, 063, 075, 090 y 110.
- Doble rodamiento de rodillos cónicos en tamaños 090 y 110.
- Lubricación permanente con aceite sintético.
- Die-cast aluminum housing on sizes 040, 050, 063, 075, 090 and 110.
- Double taper roller bearing on sizes 090 and 110.
- Permanent synthetic oil long-life lubrication.

Clasificación

Classification

REDUCTOR / GEARBOX									
CMM	040/075	FD	300	56C	SZDX	BRSX	90	M1	US1
Tipo Type	Tamaño Size	Versión Version	Relación de reducción Ratio		Eje de salida Output shaft	Brazo de reacción Torque arm	Ángulo Angle	Posición de montaje Mounting position	Ejecución de montaje Mounting execution
CMM 	040/075 040/090 050/110	U FD FS FBD FBS FLD FLS	véase tablas see tables	56C 140TC	SZDX SZSX DZ	BRSX BRDX	0° 90° 180° 270°	M1 (B3) M2 (V6) M3 (B8) M4 (V5) M5 (B7) M6 (B6)	UB1 UB2 US1 US2 UV1 UV2 UC1 UC2
CMMIS 									

Relación de reducción
Gearbox Version

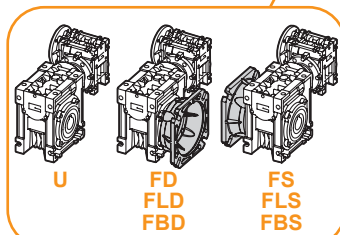

F.....D = Lado derecho / Right side
F.....S = Lado izquierdo / Left side

Eje de salida
Output shaft

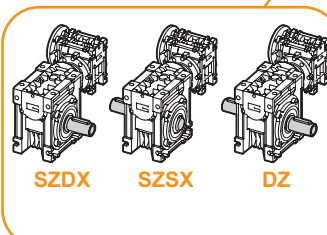

SZDX = Flecha sencilla lado derecho
Single shaft right side
DZ = Flecha doble / Double shaft
SZSX = Flecha sencilla lado izquierdo
Single shaft left side

Brazo de reacción
Torque arm

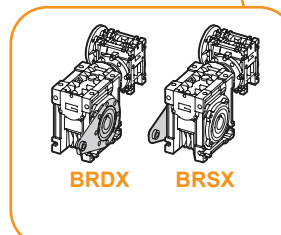

BRDX = Lado derecho / Right side
BRSX = Lado izquierdo / Left side

Posición del Brazo
Torque arm position *

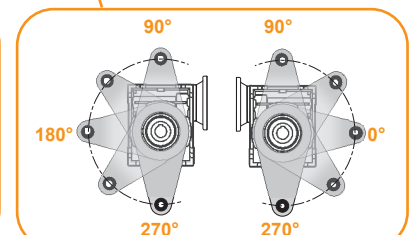

* NOTA: El brazo de reacción se suministra desmontado.
NOTE: the torque arm will be supplied not assembled.

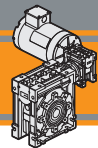

Clasificación

Classification

MOTOR / MOTOR					
1 hp / 0.75kW	4p	3ph	220/440V	60Hz	T1
Potencia Power	Polos Poles	Fases Phases	Tensión Voltage	Frecuencia Frequency	Posición caja de bornes Terminal box pos.
véase tablas See tables	2p 4p 6p 8p	1ph 3ph	230V 230/400V ... 220/440V	50Hz 60Hz	T1 (Std) T4 T2 T3

Nomenclatura

Symbols

n_1 [rpm]	Velocidad de entrada / <i>Input speed</i>	Pn_1 [hp]	Potencia nominal en la entrada / <i>Nominal input power</i>
n_2 [rpm]	Velocidad de salida / <i>Output speed</i>	Mn_2 [lb·in]	Par nominal en la salida en función de Pn_1 / <i>Nominal output torque referred to Pn_1</i>
i	Relación de reducción / <i>Ratio</i>	sf	Rendimiento dinámico / <i>Service factor</i>
P_1 [hp]	Potencia en la entrada / <i>Input power</i>	R_2 [lb]	Carga radial admisible en la salida / <i>Maximum output radial load</i>
M_2 [lb·in]	Par en la salida en función de P_1 / <i>Output torque referred to P_1</i>	A_2 [lb]	Carga axial admisible en la salida / <i>Maximum output axial load</i>

Ejecución de montaje

Mounting executions

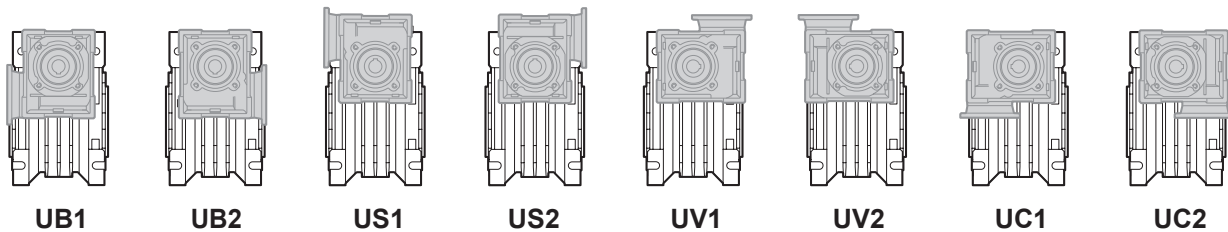

Relaciones combinadas

Combination ratio

CMM 040/075 - CMM 040/090 - CMM 050/110 - CMM 063/130																	
		$i (i_1 \times i_2)$															
		75	100	150	200	250	300	400	500	600	750	900	1200	1500	1800	2400	3000
i_1		7.5	10	10	10	10	10	10	10	20	25	30	40	50	60	60	60
i_2		10	10	15	20	25	30	40	50	30	30	30	30	30	30	40	50

Lubricación

Lubrication

La lubricación permanente con aceite sintético de larga vida (grado de viscosidad 320) hace que sea posible el uso de los reductores tamaños 40, 50, 63, 75, 90 y 110 en todas las posiciones de montaje.

Permanent synthetic oil long-life lubrication (viscosity grade 320) makes it possible to use the gearboxes size 40, 50, 63, 75, 90, 110 in all mounting positions; for this reason they can be installed in any assembly position and do not require maintenance.

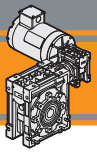

Datos t3cnicos

Technical data

P ₁ [hp]	n ₂ [rpm]	M ₂ [lb-in]	sf	AGMA	i		
------------------------	-------------------------	---------------------------	----	------	---	---	---

P ₁ [hp]	n ₂ [rpm]	M ₂ [lb-in]	sf	AGMA	i		
------------------------	-------------------------	---------------------------	----	------	---	---	---

0.16 hp

0.12 kW (1750 rpm)	23	290	15.4	III	75	CMM 040/075	56C	
	18	377	11.8	III	100		56C	
	12	530	8.8	III	150		56C	
	8.8	667	6.2	III	200		56C	
	7.0	786	4.6	III	250		56C	
	5.8	871	5.6	III	300		56C	
	4.4	1064	3.9	III	400		56C	
	3.5	1209	2.9	III	500		56C	
	2.9	1617	3.0	III	600		56C	
	2.3	1917	2.5	III	750		56C	
	1.9	2177	2.2	III	900		56C	
	1.5	2695	1.8	II	1200		56C	
	1.2	3109	1.6	II	1500		56C	
	0.97	3607	1.3	I	1800		56C	
	0.73	4408	0.9	I	2400		56C	
	0.58	3952	0.9	I	3000		56C	
	23	301	22.2	III	75		CMM 040/090	56C
	18	392	17.0	III	100			56C
	12	544	14.2	III	150			56C
	8.8	696	10.3	III	200			56C
7.0	834	7.5	III	250	56C			
5.8	914	9.1	III	300	56C			
4.4	1122	6.4	III	400	56C			
3.5	1306	4.7	III	500	56C			
2.9	1698	4.9	III	600	56C			
2.3	2013	4.1	III	750	56C			
1.9	2285	3.7	III	900	56C			
1.5	2830	2.9	III	1200	56C			
1.2	3265	2.6	III	1500	56C			
1.0	3787	2.2	III	1800	56C			
0.73	4649	1.5	II	2400	56C			
0.58	5410	1.1	I	3000	56C			
1.0	3980	3.5	III	1800	CMM 050/110	56C		
0.7	5058	2.5	III	2400		56C		
0.6	6011	1.9	II	3000		56C		

0.25 hp

0.18 kW (1750 rpm)	23	470	14.2	III	75	CMM 040/090	56C	
	18	612	10.9	III	100		56C	
	12	850	9.1	III	150		56C	
	8.8	1088	6.6	III	200		56C	
	7.0	1304	4.8	III	250		56C	
	5.8	1428	5.8	III	300		56C	
	4.4	1753	4.1	III	400		56C	
	3.5	2041	3.0	III	500		56C	
	2.9	2653	3.1	III	600		56C	
	2.3	3146	2.7	III	750		56C	
	1.9	3571	2.3	III	900		56C	
	1.5	4421	1.9	II	1200		56C	
	1.2	5101	1.6	II	1500		56C	
	1.0	5917	1.4	II	1800		56C	
	0.73	7264	1.0	I	2400		56C	
	1.9	3731	3.8	III	900		CMM 050/110	56C
	1.5	4629	3.0	III	1200			56C
	1.2	5441	2.6	III	1500			56C
	1.0	6219	2.3	III	1800			56C
	0.7	7903	1.6	II	2400			56C
0.6	9393	1.2	I	3000	56C			

0.33 hp

0.22 kW (1750 rpm)	23	597	7.5	III	75	CMM 040/075	56C	
	18	778	5.7	III	100		56C	
	12	1092	4.3	III	150		56C	
	8.8	1377	3.0	III	200		56C	
	7.0	1621	2.2	III	250		56C	
	5.8	1796	2.7	III	300		56C	
	4.4	2195	1.9	II	400		56C	
	3.5	2494	1.4	II	500		56C	
	2.9	3335	1.5	II	600		56C	
	2.3	3955	1.2	I	750		56C	
	1.9	4489	1.1	I	900		56C	
	1.5	5558	0.9	I	1200		56C	
	23	620	10.7	III	75		CMM 040/090	56C
	18	808	8.2	III	100			56C
	12	1122	6.9	III	150			56C
	8.8	1437	5.0	III	200			56C
	7.0	1721	3.7	III	250			56C
	5.8	1885	4.4	III	300			56C
	4.4	2314	3.1	III	400			56C
	3.5	2693	2.3	III	500			56C
2.9	3502	2.4	III	600	56C			
2.3	4152	2.0	III	750	56C			
1.9	4714	1.8	II	900	56C			
1.5	5836	1.4	II	1200	56C			
1.2	6734	1.2	I	1500	56C			
1.0	7811	1.1	I	1800	56C			



0.25 hp

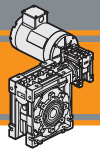

0.18 kW (1750 rpm)	23	453	9.8	III	75	CMM 040/075	56C
	18	589	7.6	III	100		56C
	12	828	5.7	III	150		56C
	8.8	1043	4.0	III	200		56C
	7.0	1228	2.9	III	250		56C
	5.8	1360	3.6	III	300		56C
	4.4	1663	2.5	III	400		56C
	3.5	1889	1.9	II	500		56C
	2.9	2526	1.9	II	600		56C
	2.3	2996	1.6	II	750		56C
	1.9	3401	1.4	II	900		56C
	1.5	4211	1.1	I	1200		56C
	1.2	4858	1.0	I	1500		56C
	0.97	5636	0.9	I	1800		56C







Datos técnicos

Technical data

P ₁ [hp]	n ₂ [rpm]	M ₂ [lb·in]	sf	AGMA	i		
0.33 hp							
0.22 kW (1750 rpm)	2.9	3603	3.9	III	600	CMM 050/110	56C
	2.3	4332	3.3	III	750		
	1.9	4925	2.9	III	900		
	1.5	6111	2.3	III	1200		
	1.2	7183	2.0	II	1500		
	1.0	8209	1.7	II	1800		
	0.7	10432	1.2	I	2400		
	0.6	12399	0.9	I	3000		

P ₁ [hp]	n ₂ [rpm]	M ₂ [lb·in]	sf	AGMA	i		
0.75 hp							
0.55 kW (1750 rpm)	23	1427	8.3	III	75	CMM 050/110	56C
	18	1858	6.3	III	100		
	12	2615	5.0	III	150		
	8.8	3395	3.6	III	200		
	7.0	4130	2.8	III	250		
	5.8	4405	3.2	III	300		
	4.4	5598	2.3	III	400		
	3.5	6653	1.7	II	500		
	2.9	8188	1.7	II	600		
	2.3	9846	1.4	II	750		
	1.9	11194	1.3	I	900		
	1.5	13888	1.0	I	1200		
	1.2	16324	0.9	I	1500		

P ₁ [hp]	n ₂ [rpm]	M ₂ [lb·in]	sf	AGMA	i				
0.5 hp									
0.37 kW (1750 rpm)	23	905	4.9	III	75	CMM 040/075	56C		
	18	1179	3.8	III	100				
	12	1655	2.8	III	150				
	8.8	2086	2.0	II	200				
	7.0	2456	1.5	II	250				
	5.8	2721	1.8	II	300				
	4.4	3325	1.3	I	400				
	3.5	3779	0.9	I	500				
	2.9	5053	1.0	I	600				
	23	940	7.1	III	75			CMM 040/090	56C
	18	1224	5.4	III	100				
	12	1700	4.5	III	150				
	8.8	2177	3.3	III	200				
	7.0	2607	2.4	III	250				
	5.8	2857	2.9	III	300				
	4.4	3507	2.1	III	400				
	3.5	4081	1.5	II	500				
	2.9	5305	1.6	II	600				
	2.3	6292	1.3	I	750				
	1.9	7142	1.2	I	900				
	1.5	8842	0.9	I	1200				
	5.8	2937	4.8	III	300	CMM 050/110	56C		
	4.4	3732	3.4	III	400				
	3.5	4436	2.5	III	500				
	2.9	5459	2.6	III	600				
	2.3	6564	2.2	III	750				
	1.9	7462	1.9	II	900				
	1.5	9259	1.5	II	1200				
	1.2	10883	1.3	I	1500				
	1.0	12437	1.1	I	1800				

P ₁ [hp]	n ₂ [rpm]	M ₂ [lb·in]	sf	AGMA	i		
1 hp							
0.75 kW (1750 rpm)	23	1902	6.2	III	75	CMM 050/110	56C
	18	2478	4.8	III	100		
	12	3487	3.8	III	150		
	8.8	4527	2.7	III	200		
	7.0	5506	2.1	III	250		
	5.8	5873	2.4	III	300		
	4.4	7464	1.7	II	400		
	3.5	8871	1.3	I	500		
	2.9	10917	1.3	I	600		
	2.3	13128	1.1	I	750		
	1.9	14925	0.9	I	900		

CMM

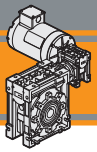

Motores Aplicables IEC

IEC Motor adapters

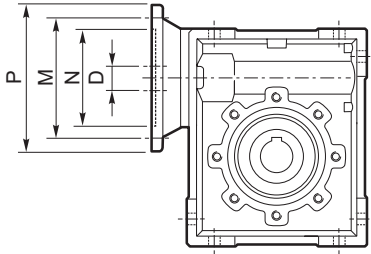

NOTA / NOTE

Las 3reas grises indican la aplicabilidad del correspondiente tama1o del motor.

Grey areas indicate motor inputs available on each size of unit.

B/BS = Buje de metal para flecha

B/BS = Metal shaft sleeve

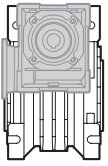

UB1

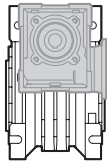

UB2

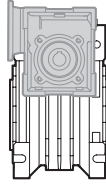

US1

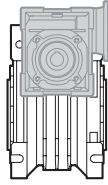

US2

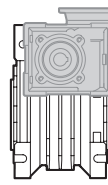

UV1

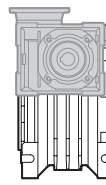

UV2

CMM	NEMA	N	M	P	D	i ₁								
						7.5	10	20	25	30	40	50	60	
040/075	56C	4.5	5.88	6.5	0.625									
040/090														
050/110														

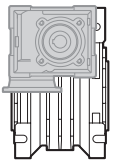

UC1

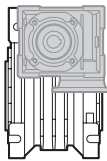

UC2

CMM	NEMA	N	M	P	D	i ₁							
						7.5	10	20	25	30	40	50	60
050/110	56C	4.5	5.88	6.5	0.625								

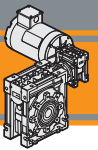

Dimensiones

Dimensions

CMM 040/075

CMM 040/075 U

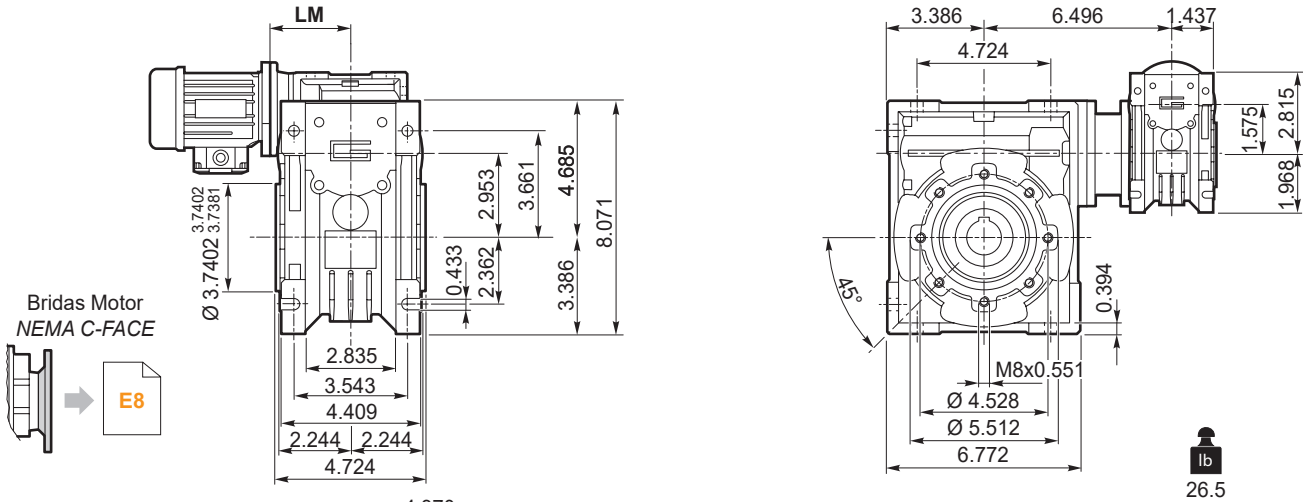

CMM 040/075 F

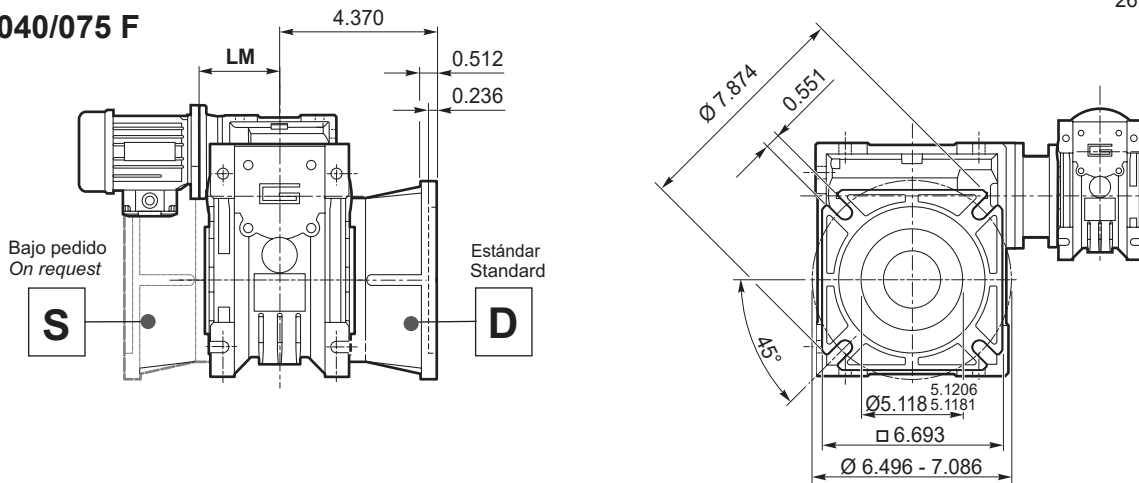

CMMIS 040/075 ..

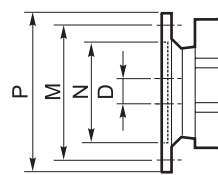
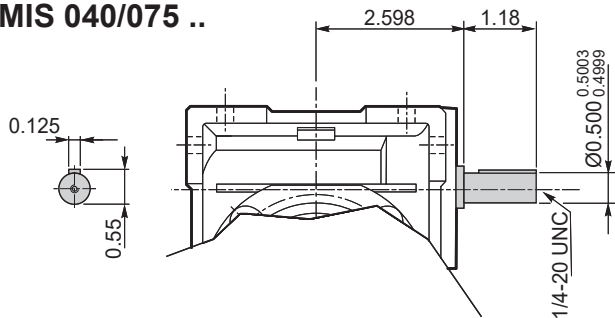

Brida Motor / Motor flange	
Dimensiones NEMA NEMA Dimensions	
	56 C
N	4.5
M	5.88
P	6.5
D	0.625
LM	3.15

Eje de salida hueco / Hollow output shaft

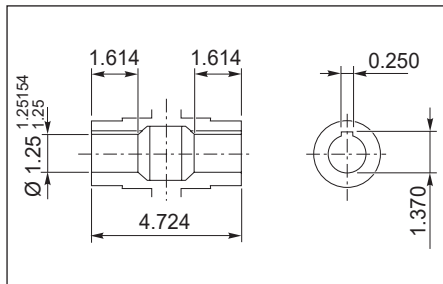

Eje de salida / Output shaft

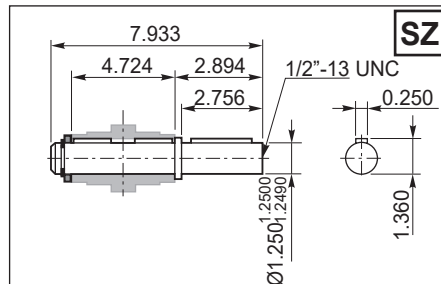

Eje de salida / Output shaft

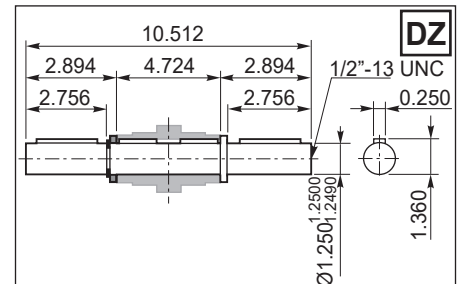

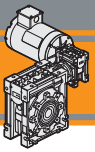

Dimensiones

Dimensions

CMM 040/090

CMM 040/090 U

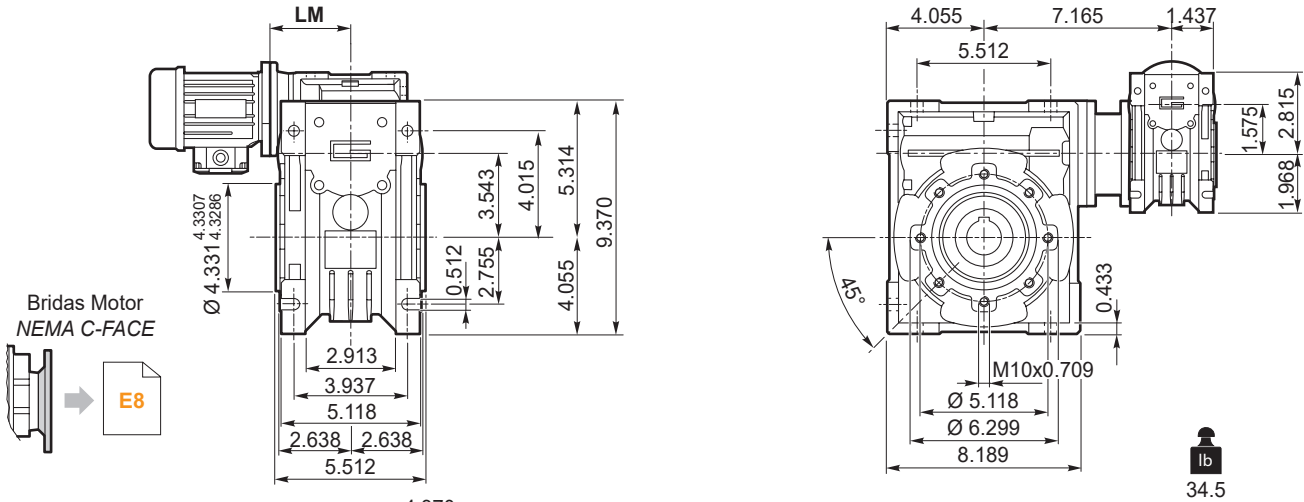

CMM 040/090 F

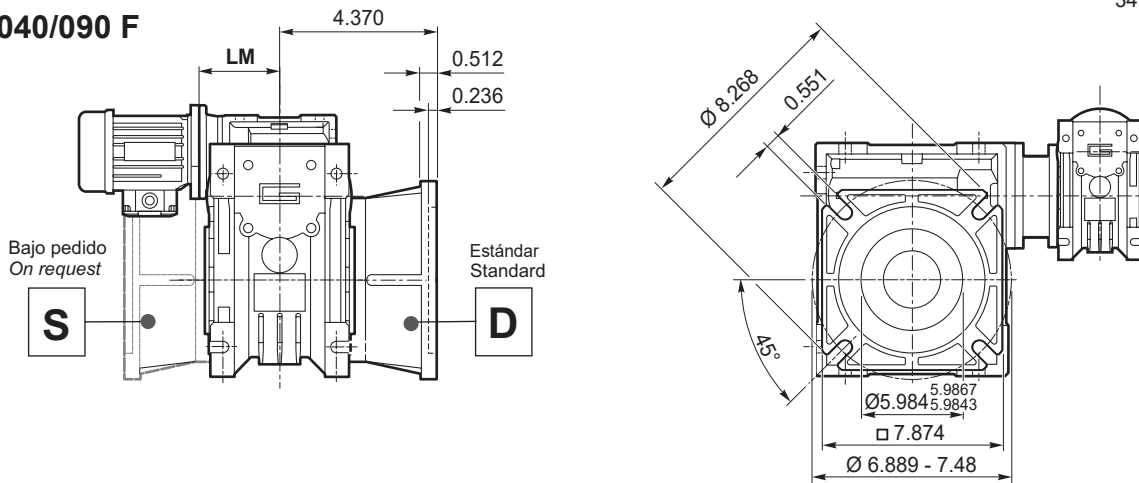

CMMIS 040/090 ..

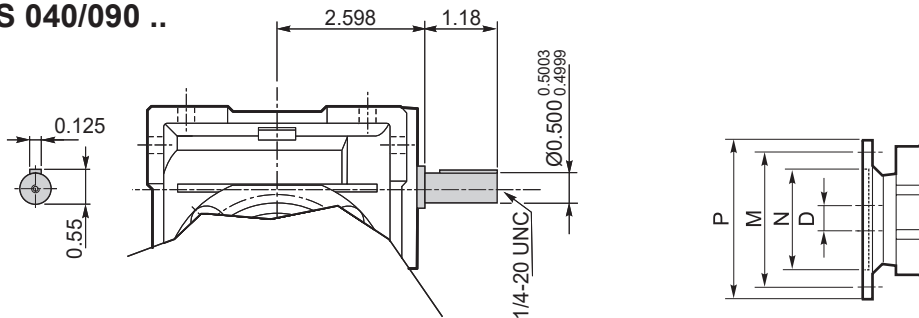

Brida Motor / Motor flange	
Dimensiones NEMA NEMA Dimensions	
	56 C
N	4.5
M	5.88
P	6.5
D	0.625
LM	3.15

Eje de salida hueco / Hollow output shaft

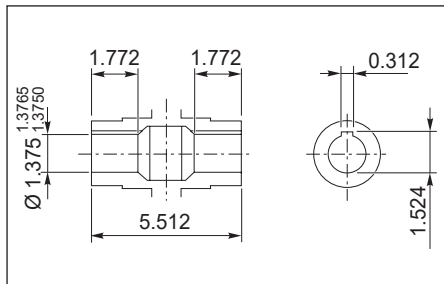

Eje de salida / Output shaft

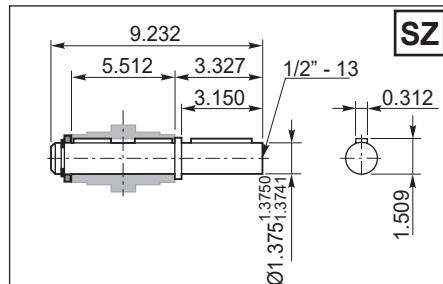

Eje de salida / Output shaft

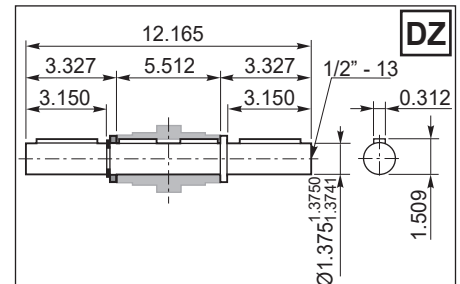

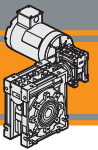

Dimensiones

Dimensions

CMM 050/110

CMM 050/110 U

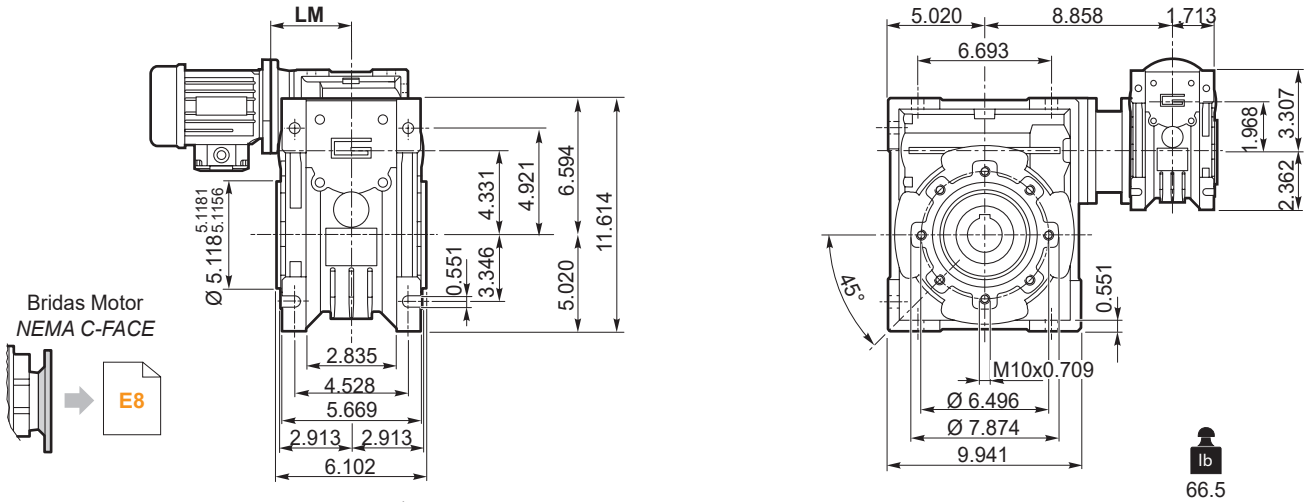

CMM 050/110 F

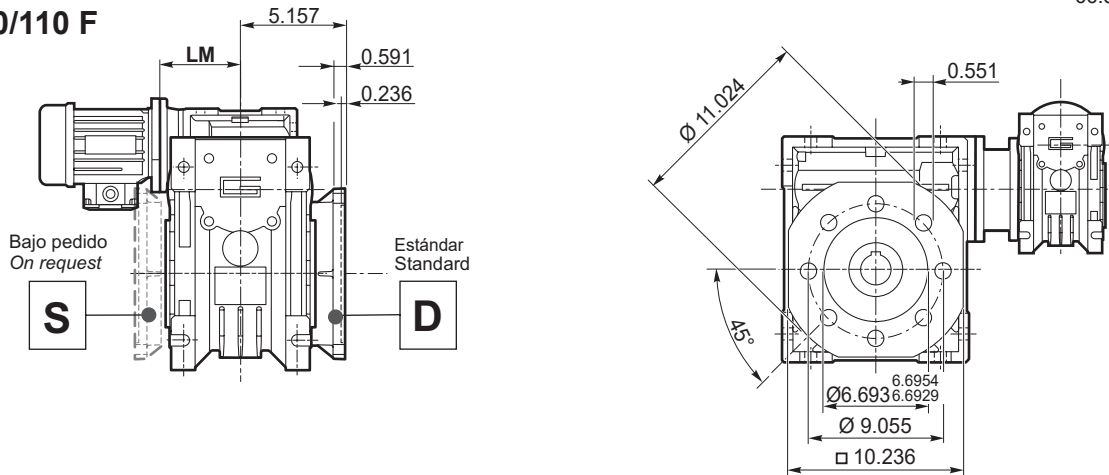

CMMIS 050/110 ..

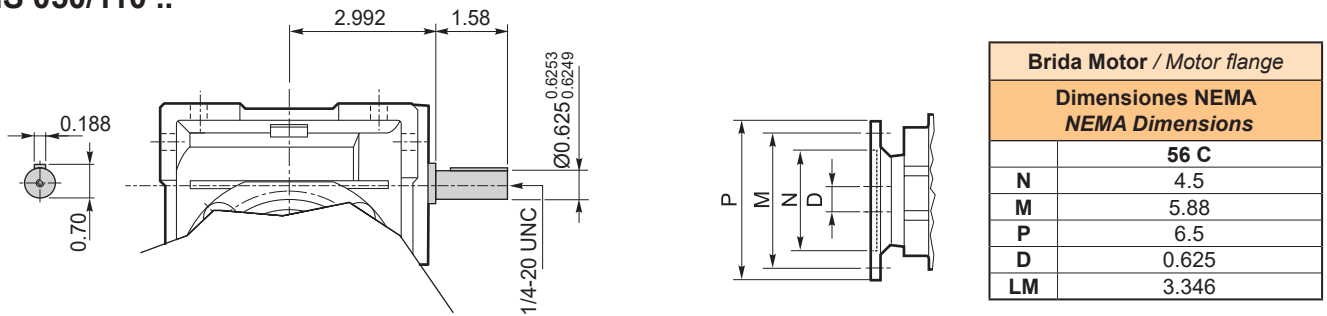

Eje de salida hueco / Hollow output shaft

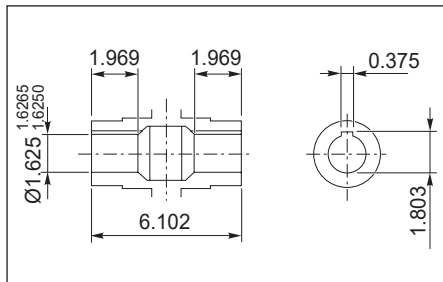

Eje de salida / Output shaft

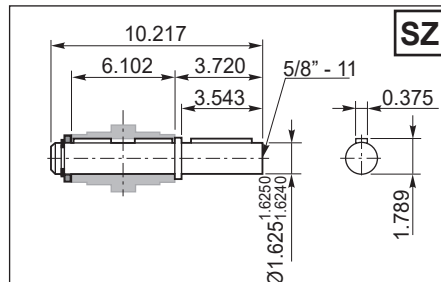

Eje de salida / Output shaft

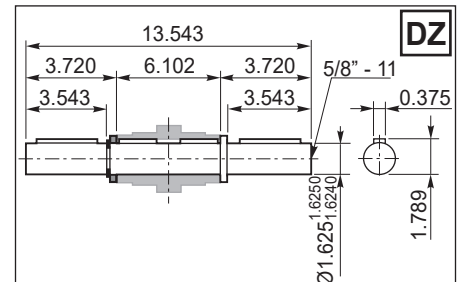

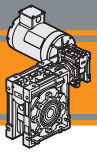

Accesorios

Accessories

Eje de salida simple y doble

Single and double output shaft

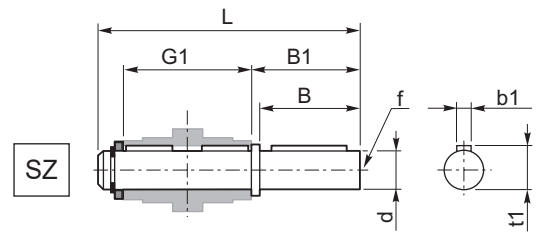
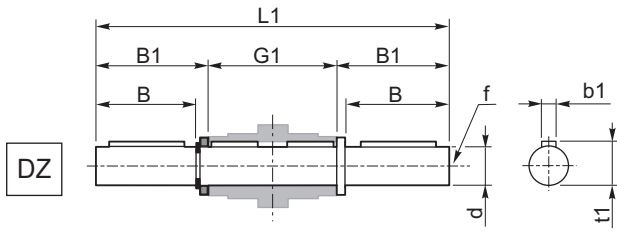

CMM	d	B	B1	G1	L	L1	f	b1	t1
040/075	1.250 <small>1.250 1.249</small>	2.756	2.894	4.724	7.933	10.512	1/2"-13	0.250	1.360
040/090	1.375 <small>1.375 1.3741</small>	3.150	3.327	5.512	9.232	12.165	1/2"-13	0.312	1.509
050/110	1.625 <small>1.625 1.624</small>	3.543	3.720	6.102	10.217	13.543	5/8"-11	0.375	1.789

Brazo de reacción

Torque arm

CMM	K1	G	KG	KH	R
040/075	7.874	0.984	1.831	0.787	1.181
040/090	7.874	0.984	2.224	0.787	1.181
050/110	9.843	1.181	2.441	0.984	1.378

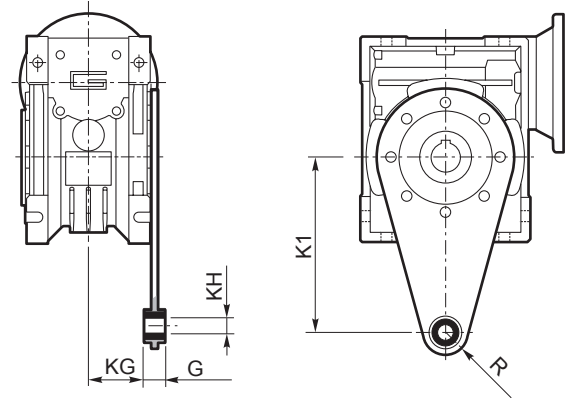

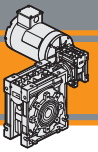

SC - Cubierta de seguridad / Safety Cover

CM	M
040	2.14
050	2.46
075	3.11
090	3.70
110	4.02

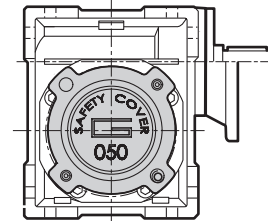
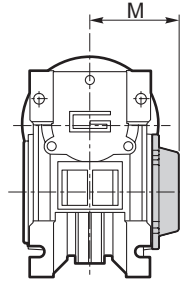

CMM

WD - Kit washdown cover

CM	M
040	2.19
050	2.50
075	3.15
090	3.74
110	4.06

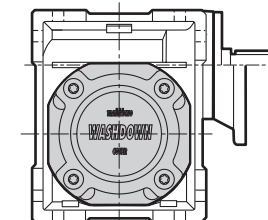
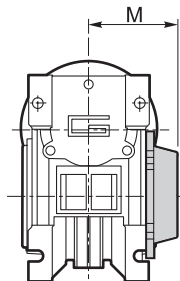

 **TRANSTECNO SRL**
HEADQUARTERS
Via Caduti di Sabbiano, 11/D-E
40011 Anzola dell'Emilia (BO)
ITALY
T+39 051 64 25 811
F +39 051 73 49 43
sales@transtecno.com
www.transtecno.com

TRANSTECNO®
the modular gearmotor
MEMBER OF INTERPUMP GROUP

CATALUNYA0920



 **HANGZHOU TRANSTECNO POWER TRANSMISSIONS CO LTD**
No.4 Xiuyan Road Fengdu Industry Zone
Pingyao Town Yuhang District
Hangzhou City, Zhejiang Province
311115 - CHINA
T +86 571 86 92 02 60
F +86 571 86 92 18 10
info-china@transtecno.cn
www.transtecno.cn

 **MA TRANSTECNO S.A.P.I. DE C.V.**
Av. Mundial # 176, Parque Industrial
JM Apodaca, Nuevo León,
C.P. 66600 - MÉXICO
T +52 8113340920
info@transtecno.com.mx
www.transtecno.com.mx

 **TRANSTECNO IBÉRICA**
THE MODULAR GEARMOTOR, S.A.
C/Enginy, 2 Nave 6
08850 Gavà (Barcelona) - SPAIN
T +34 931 598 950
info@transtecno.es
www.transtecno.es

 **TRANSTECNO B.V.**
De Stuwdam,43
3815 KM Amersfoort - NETHERLANDS
T +31(0) 33 45 19 505
F +31(0) 33 45 19 506
info@transtecno.nl
www.transtecno.nl

 **TRANSTECNO AANDRIJFTECHNIEK B.V.**
De Stuwdam 43
3815 KM Amersfoort - NETHERLANDS
T +31 (0) 33 20 4 7 006
info@transtecnoandrijftechnik.nl
www.transtecnoandrijftechnik.nl

 **TRANSTECNO USA**
8 Creek Parkway,
Boothwyn PA 19061-8136
UNITED STATES
T + 1 (610) 4970154
F +1 (610) 497 6085
14561 Fryelands Blvd SE
Monroe, WA 98272 - UNITED STATES
T +1 360-863-1300
F +1 360-863-1303
usaoffice@transtecno.com
www.transtecno.com

 **TRANSTECNO CANADA**
51 B Caldari Road Unit 10
Vaughan, ON L4K 4G3 - CANADA
T +1 905 761 0762
F +1 905 761 9265
canadaoffice@transtecno.com
www.transtecno.com

 **TRANSTECNO CHILE-PERU**
Av. Los Libertadores 41
Parque Industrial - Los Libertadores 16.500
Santiago, Colina - CHILE
T +56 2 29633870
Carretera Panamericana Sur KM 29.5,
Interior I-3, Z.I. Lurin - PERU
T +51 1 3546259 / +51 1 3434231
chileoffice@transtecno.com
www.transtecno.com

 **SALES OFFICE BRAZIL**
Rua Dr. Freire Alemão 155 / 402 - CEP. 90450-060
Auxiliadora Porto Alegre RS - BRAZIL
T +55 51 3251 5447
F +55 51 3251 5447
M +55 51 811 45 962
braziloffice@transtecno.com
www.transtecno.com.br

 **SALES OFFICE OCEANIA**
44 Northview drive, Sunshine west 3020
Victoria - AUSTRALIA
T +61 03 9312 4722
F +61 03 9312 4714
M +61 0438060997
oceaniaoffice@transtecno.com
www.transtecno.com.au

 **SALES OFFICE INDIA**
Woodbine 2003/04, Everest World
Kolshet Road, Thane west Mumbai 400607
INDIA
T +91 982 061 46 98
indiaoffice@transtecno.com
www.transtecno.com

 **SALES OFFICE SOUTH KOREA**
410-7. Samrae-eup, Wanju-goon, Chonbuk 55332
SOUTH KOREA
T +82 70 8867 8897
F +82 504 199 2107
M +82 10 5094 2107
koreaoffice@transtecno.com
www.transtecno.com