

TRANSTECNO[®]
the modular gearmotor

CM



60Hz

Nema

Motorreductores sinfín corona
Wormgearmotors

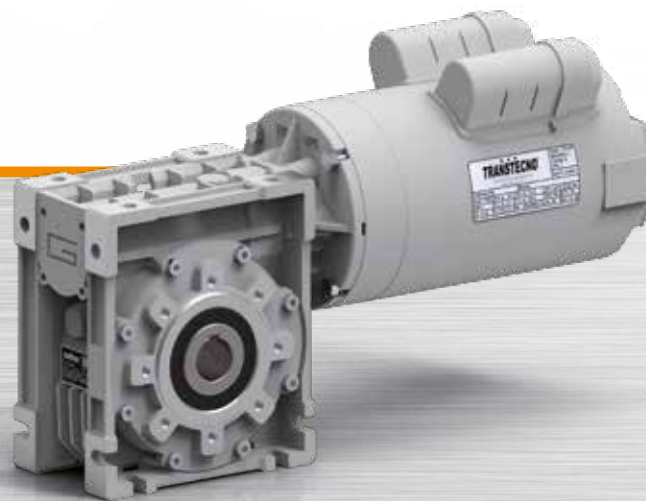

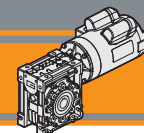

Índice	Index	Pág. Page
Características técnicas	<i>Technical features</i>	D2
Clasificación	<i>Classification</i>	D2
Sentidos de rotación	<i>Direction of rotation</i>	D3
Nomenclatura	<i>Symbols</i>	D3
Lubricación	<i>Lubrication</i>	D3
Cargas radiales	<i>Radial loads</i>	D3
Reversibilidad e irreversibilidad	<i>Reversibility and irreversibility</i>	D4
Datos de dentado	<i>Toothing data</i>	D5
Rendimiento	<i>Efficiency</i>	D5
Datos técnicos	<i>Technical data</i>	D6
Dimensiones	<i>Dimensions</i>	D12
Accesorios	<i>Accessories</i>	D24
Opciones	<i>Options</i>	D25

Esta sección substituye y anula las ediciones y revisiones previas. Si usted obtiene este catálogo a través de canales de distribución no autorizados o fuera de nuestro control, la versión en vigor no estará garantizada. **En todo caso, la versión más actualizada está disponible en nuestra página de internet www.transtecno.com**

*This section replaces any previous edition and revision. If you obtained this catalogue other than through controlled distribution channels, the most up to date content is not guaranteed. **In this case the latest version is available on our web site www.transtecno.com***

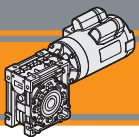

CM

Motorreductores sinfín corona
Wormgearboxes

Nema 60 Hz

Características técnicas

Technical features

El elevado nivel de modularidad caracteriza a los reductores sinfín corona de la serie CM; los diversos kit de entrada y salida permiten una versatilidad extrema del reductor. Los reductores de la serie CM poseen las características siguientes:

The high degree of modularity is a design feature of CM wormgearboxes range thanks to a wide selection of input and output kits. Main features of CM range are:

- Los tamaños 040, 050, 063, 075, 090 y 110 están contruidos con carcasa de aluminio;
- Los tamaños 090 y 110 se suministran con rodamientos de rodillos cónicos en el sinfín;
- Die-cast aluminum housing on sizes 040, 050, 063, 075, 090 and 110;
- Double taper roller bearing on sizes 090 and 110;

Clasificación

Classification

REDUCTORES SINFIN CORONA / WORMGEARBOXES

REDUCTOR / GEARBOX								
CM	050	U	10	56C	SZDX	BRSX	90°	M1
Tipo Type	Tamaño Size	Versión de reductor Gearbox Version	Relación de reducción Ratio		Eje de salida Output shaft	Brazo de reacción Torque arm	Ángulo Angle	Posición de montaje Mounting position
CM 	040 050 063 075	U FD FS FBD	véase tablas see tables	56C 140TC 180TC 210TC	SZDX SZSX DZ	BRSX BRDX	0° 90° 180° 270°	M1 (B3) M2 (V6) M3 (B8) M4 (V5) M5 (B7) M6 (B6)
CMIS 	090 110	FBS FLD FLS						

Relación de reducción
Gearbox Version

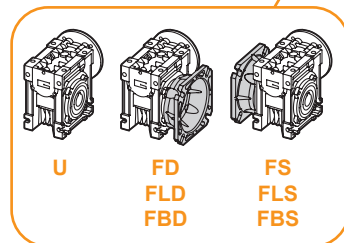

F.....D = Lado derecho / Right side
F.....S = Lado izquierdo / Left side

Eje de salida
Output shaft

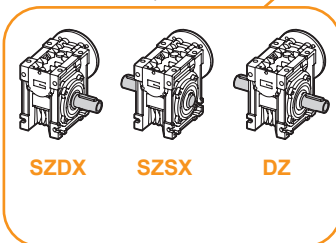

SZDX = Flecha sencilla lado derecho
Single shaft right side
DZ = Flecha doble / Double shaft
SZSX = Flecha sencilla lado izquierdo
Single shaft left side

Brazo de reacción
Torque arm

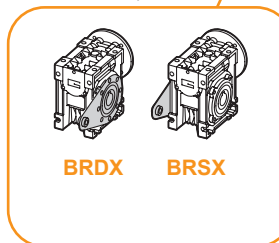

BRDX = Lado derecho / Right side
BRSX = Lado izquierdo / Left side

Posición del Brazo
Torque arm position *

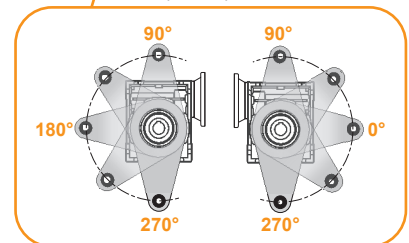

* NOTA: El brazo de reacción se suministra desmontado.
NOTE: the torque arm will be supplied not assembled.

MOTOR / MOTOR

1 hp / 0.75kW	4p	3ph	220/440V	60Hz	T1
Potencia Power	Polos Poles	Fases Phases	Tensión Voltage	Frecuencia Frequency	Posición caja de bornes Terminal box pos.
véase tablas See tables	2p 4p 6p 8p	1ph 3ph	230V 230/400V ... 220/440V	50Hz 60Hz	T1 (Std)

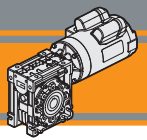

Sentidos de rotación

Direction of rotation

CM

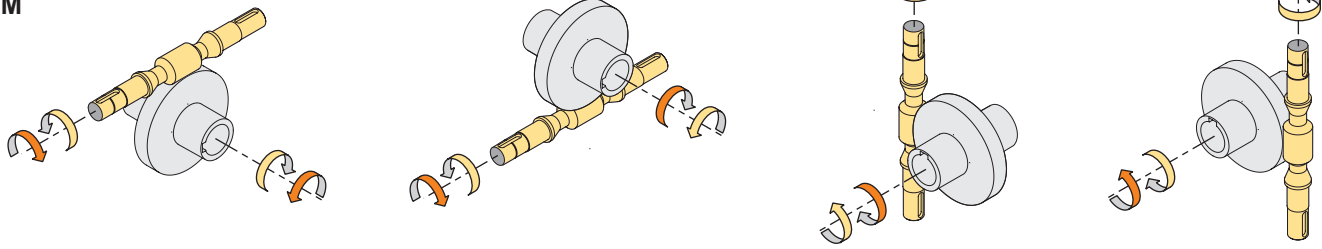

Nomenclatura

Symbols

n_1 [rpm]	Velocidad de entrada / <i>Input speed</i>	sf	Rendimiento dinámico / <i>Service factor</i>
n_2 [rpm]	Velocidad de salida / <i>Output speed</i>	Rd %	Rendimiento dinámico / <i>Dynamic efficiency</i>
i	Relación de reducción / <i>Ratio</i>	Rs %	Rendimiento estático / <i>Static efficiency</i>
P_1 [hp]	Potencia en la entrada / <i>Input power</i>	R_2 [lb]	Carga radial admisible en la salida / <i>Maximum output radial load</i>
M_2 [lb·in]	Par en la salida en función de P_1 / <i>Output torque referred to P_1</i>	A_2 [lb]	Carga axial admisible en la salida / <i>Maximum output axial load</i>
Pn_1 [hp]	Potencia nominal en la entrada / <i>Nominal input power</i>	Z	Número de entradas del tornillo / <i>Worm starts</i>
Mn_2 [lb·in]	Par nominal en la salida en función de Pn_1 / <i>Nominal output torque referred to Pn_1</i>	β	Ángulo de hélicoïdal / <i>Helix angle</i>

Lubricación

Lubrication

Lubricación permanente de aceite sintético de larga vida (grado de viscosidad 320) que hace posible utilizar los reductores en todas las posiciones de montaje, así mismo no requieren de mantenimiento eliminando el cambio de aceite.

Permanent synthetic oil long-life lubrication (viscosity grade 320) makes it possible to use the gearboxes in all mounting positions; for this reason they can be installed in any assembly position and do not require maintenance.

Cargas radiales

Radial loads

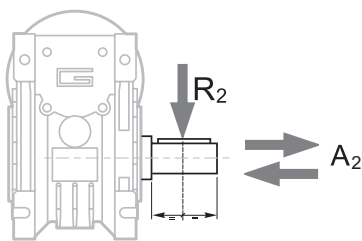

$A_2 = R_2 \times 0.2$

n_2 [rpm]	R_2 [lb]					
	CM040	CM050	CM063	CM075	CM090	CM110
187	284	398	550	635	711	1137
140	313	438	605	699	783	1252
93	359	502	694	801	897	1435
70	394	552	763	881	986	1578
56	425	595	821	949	1062	1699
47	450	631	871	1006	1126	1802
35	497	696	961	1110	1242	1988
28	535	749	1035	1195	1338	2141
23	572	800	1105	1277	1429	2286
18	620	868	1199	1385	1551	2481
14	674	944	1304	1506	1686	2698

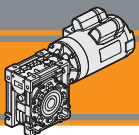

Cargas radiales

Radial loads

Cuando la carga radial no se aplica en el punto medio del eje, es necesario calcular la carga efectiva a través la siguiente fórmula:

When the radial load is not applied on the centre line of the shaft it is necessary to calculate the effective load with the following formula:

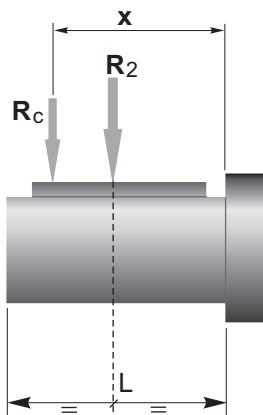

	CM					
	040	050	063	075	090	110
a	84	101	120	131	182	176
b	64	76	95	101	122	136
R_{2MAX}	674	944	1304	1506	1686	2698

$$R_c = \frac{R_2 \cdot a}{(b+x)} \leq R_{2MAX}$$

$$R \leq R_c$$

a, b = valores dados en la tabla
a, b = values given in the table

Reversibilidad e irreversibilidad

Reversibility and irreversibility

La reversibilidad en los motorreductores sinfín y corona es consecuencia directa de la eficiencia (estática y dinámica). Esto determina si la flecha de entrada puede o no ser rotada por la aplicación de un cierto torque en la flecha de salida.

Reversibility of the wormgearbox is the direct consequence of efficiency (static and dynamic). This determines whether or not the input shaft can be rotated by applying a certain torque on the output shaft.

El grado de reversibilidad (o irreversibilidad) de un reductor está determinado por la dificultad de poder o no poder rotarlo. Esta significativa característica de los reductores sinfín y corona es afectada por numerosos factores incluyendo el ángulo de diseño de los engranes (así como la relación de reducción), lubricación, temperatura, el maquinado de la superficie del sinfín, vibraciones, etc.

Whether or not this can be done and how difficult it actually is to determine the degree of reversibility (or irreversibility) of a gearbox. This feature, quite significant in wormgearboxes, is affected by numerous factors including the helix angle (therefore drive ratio), lubrication, temperature, surface finish of the worm, vibrations, etc...

En aplicaciones de traslación, una alta reversibilidad debe ser garantizada en el reductor para evitar inercias de las partes en movimiento o picos de carga inaceptables para los engranes.

In applications that include translations, high reversibility must be guaranteed to prevent inertia of the moving parts from creating unacceptable load peaks on the drive parts.

En las aplicaciones que requieren un “no-retorno” de la carga (ej. Elevadores o bandas transportadoras inclinadas) un reductor con alta irreversibilidad debe ser seleccionado cuando no se cuenta con un motor con freno.

In applications that require non-return of the load (e.g. lifting or inclined conveyor belts) a gearbox with high irreversibility must be chosen when a motor-brake unit is not present.

Sin embargo debemos mencionar que el no retorno de la carga debe ser totalmente garantizado solamente instalando un motor auto frenante (u otro dispositivo externo).

However, we would like to point out that non-return can be totally assured only by installing a self-braking motor or other external braking device.

La siguiente tabla se proporciona únicamente con fines de referencia. En esta se muestran los distintos grados de reversibilidad e irreversibilidad de los reductores sinfín y corona en relación a su eficiencia dinámica Rd y estática Rs.

The table below is provided for reference purposes only. It contains the various degrees of reversibility/irreversibility of wormgearboxes in relation to dynamic Rd and static Rs efficiency.

Rd	Reversibilidad e irreversibilidad dinámica	Dynamic reversibility and irreversibility
> 0.6	Reversibilidad dinámica	Dynamic reversibility
0.5 - 0.6	Reversibilidad dinámica incierta	Uncertain dynamic reversibility
0.4 - 0.5	Irreversibilidad dinámica efectiva	Good dynamic irreversibility
<0.4	Irreversibilidad dinámica	Dynamic irreversibility
Rs	Reversibilidad e irreversibilidad estática	Static reversibility and irreversibility
> 0.55	Irreversibilidad estática	Static reversibility
0.5 - 0.55	Opción A: Reversibilidad estática incierta	Uncertain static reversibility
<0.5	Irreversibilidad estática	Static irreversibility

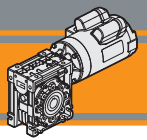

Datos de dentado

Toothing data

	Datos del engranaje sinfin corona Worm wheel data	Relación de reducción / Ratio											
		5	7.5	10	15	20	25	30	40	50	60	80	100
CM040	Z	6	4	3	2	2	2	1	1	1	1	1	1
	β	34° 19'	24° 28'	18° 50'	12° 49'	10° 23'	8° 43'	6° 29'	5° 14'	4° 23'	3° 46'	2° 57'	2° 25'
CM050	Z		4	3	2	2	2	1	1	1	1	1	1
	β		23° 54'	18° 23'	12° 29'	10° 6'	8° 28'	6° 19'	5° 5'	4° 15'	3° 39'	2° 51'	2° 20'
CM063	Z		4	3	2	2	2	1	1	1	1	1	1
	β		24° 31'	18° 53'	12° 50'	10° 24'	8° 44'	6° 30'	5° 14'	4° 23'	3° 47'	2° 57'	2° 25'
CM075	Z		4	3	2	2	2	1	1	1	1	1	1
	β		26° 17'	20° 20'	13° 52'	11° 18'	9° 32'	7° 2'	5° 42'	4° 48'	4° 8'	3° 14'	2° 40'
CM090	Z		4	3	2	2	2	1	1	1	1	1	1
	β		29° 11'	22° 43'	15° 36'	12° 50'	10° 53'	7° 56'	6° 30'	5° 29'	4° 45'	3° 45'	3° 6'
CM110	Z		4	3	2	2	2	1	1	1	1	1	1
	β		28° 14'	21° 56'	15° 1'	14° 41'	12° 34'	7° 38'	7° 28'	6° 21'	5° 32'	4° 24'	3° 39'

CM

Rendimiento

Efficiency

	n ₁ [rpm]	Rendimiento Efficiency	Relación de reducción / Ratio											
			5	7.5	10	15	20	25	30	40	50	60	80	100
CM040	1750	Rd	88	86	84	81	78	74	70	65	60	58	52	46
		Rs	74	71	67	60	55	51	45	40	36	32	28	24
CM050	1750	Rd	89	87	85	82	79	76	72	67	63	60	54	49
		Rs	73	70	66	59	55	51	44	39	35	32	27	23
CM063	1750	Rd	90	88	86	84	81	78	75	70	66	63	57	52
		Rs	73	71	67	60	55	51	45	40	36	33	28	24
CM075	1750	Rd		89	87	84	83	80	77	73	69	66	60	56
		Rs		73	69	62	59	55	48	43	39	36	31	27
CM090	1750	Rd		90	88	86	84	83	79	76	72	69	64	60
		Rs		74	71	65	61	59	51	46	42	39	34	30
CM110	1750	Rd		89	88	86	85	84	80	79	76	73	68	64
		Rs		74	71	64	64	60	50	49	46	42	37	33



Rendimiento teórico del reductor después del rodaje
Theoretical efficiency of the gearbox after the first running period

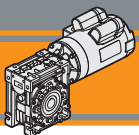

Datos técnicos

Technical data

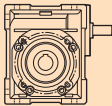
	i	n ₁ = 1750 rpm			NEMA Motores aplicables NEMA Motor adapters 56 C
		n ₂ [rpm]	Mn ₂ [lb·in]	Pn ₁ [hp]	
CMIS 40					
	5	350	363	2.29	
	7.5	233	389	1.68	
	10	175	398	1.32	
	15	117	398	0.91	
	20	88	354	0.63	
	25	70	336	0.50	
	30	58	425	0.56	
	40	44	372	0.40	
	50	35	345	0.32	
	60	29	319	0.25	
	80	22	292	0.19	
	100	18	274	0.17	

CMIS 50					
	5	350	664	4.14	
	7.5	233	699	2.97	
	10	175	726	2.37	
	15	117	726	1.64	
	20	88	637	1.12	
	25	70	620	0.90	
	30	58	779	1.00	
	40	44	673	0.70	
	50	35	637	0.56	
	60	29	611	0.47	
	80	22	531	0.34	
	100	18	496	0.28	

NOTA Las áreas resaltadas indican el tamaño de carcasa del motor correspondiente.

NOTE Highlighted áreas indicate the motor input flange available on each gearbox size.

Antes de seleccionar cualquier reductor, favor de revisar los valores de desempeño en las páginas C8 a la C11.

Before selecting any gearbox, please read the performance values shown in the tables on page C8 to C11.

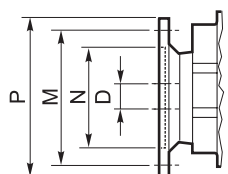

Dimensiones NEMA/ NEMA Dimensions	
	56 C
N	4.5
M	5.88
P	6.5
D	0.625

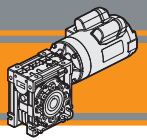

Datos técnicos

Technical data

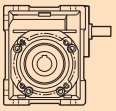
	i	n ₁ = 1750 rpm					
		n ₂ [rpm]	Mn ₂ [lb·in]	Pn ₁ [hp]	NEMA Motores aplicables NEMA Motor adapters		
					56 C	140 TC	180 TC
CMIS 63							
	5	350	1186	7.31	B		
	7.5	233	1274	5.36	B		
	10	175	1310	4.23	B		
	15	117	1363	3.00	B		
	20	88	1204	2.06	B		
	25	70	1195	1.70	B		
	30	58	1469	1.81	B		
	40	44	1257	1.25			
	50	35	1204	1.01			
	60	29	1115	0.82			
	80	22	1044	0.64			
	100	18	1027	0.55			

CMIS 75							
	7.5	233	2106	8.76	BS	B	
	10	175	2274	7.25	BS	B	
	15	117	2354	5.18	BS	B	
	20	88	2142	3.58	B		
	25	70	1991	2.76	B		
	30	58	2531	3.04	B		
	40	44	2221	2.11	B		
	50	35	2009	1.62	B		
	60	29	1929	1.35			
	80	22	1708	0.99			
	100	18	1620	0.80			

NOTA

Las áreas resaltadas indican el tamaño de carcasa del motor correspondiente.

B/BS = Casquillo de reducción en acero.



* = Pn₁ es la potencia mecánica. La potencia aplicable resulta reducida por el factor térmico. Para más detalles consultar con nuestro servicio técnico

Antes de seleccionar cualquier reductor, favor de revisar los valores de desempeño en las páginas C8 a la C11.

NOTE

Highlighted áreas indicate the motor input flange available on each gearbox size.

B/BS = Metal shaft sleeve.



* = The service factor (sf) has to be selected depending on application: please contact our Technical Department.

Before selecting any gearbox, please read the performance values shown in the tables on page C8 to C11.

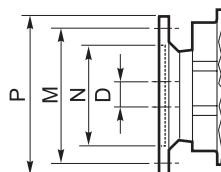

Dimensiones NEMA/ NEMA Dimensions			
	56 C	140 TC	180 TC
N	4.5		8.5
M	5.88		7.25
P	6.5		9
D	0.625	0.875	1.125

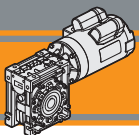

Datos técnicos

Technical data

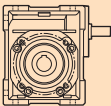
	i	n ₁ = 1750 rpm						
		n ₂ [rpm]	Mn ₂ [lb·in]	Pn ₁ [hp]	NEMA Motores aplicables NEMA Motor adapters			
					56 C	140 TC	180 TC	210 TC
CMIS 90								
	7.5	233	3027	12.44	BS	B		
	10	175	3363	10.60	BS	B		
	15	117	3832	8.24	BS	B		
	20	88	3664	6.05	BS	B		
	25	70	3266	4.37	BS	B		
	30	58	4363	5.11	BS	B		
	40	44	3841	3.51	B			
	50	35	3407	2.63	B			
	60	29	3115	2.09	B			
	80	22	2867	1.55				
	100	18	2646	1.22				

CMIS 110							
	7.5	233	5354	22.26	BS	B	
	10	175	5921	18.67	BS	B	
	15	117	6461	13.90	BS	B	
	20	88	6549	10.69	BS	B	
	25	70	5930	7.83	B		
	30	58	7213	8.34	B		
	40	44	6797	5.97	B		
	50	35	6186	4.52	B		
	60	29	5540	3.51	B		
	80	22	4974	2.54			
	100	18	4629	2.01			

NOTA

Las áreas resaltadas indican el tamaño de carcasa del motor correspondiente.

B/BS = Casquillo de reducción en acero.



* = Pn₁ es la potencia mecánica. La potencia aplicable resulta reducida por el factor térmico. Para más detalles consultar con nuestro servicio técnico

Antes de seleccionar cualquier reductor, favor de revisar los valores de desempeño en las páginas C8 a la C11.

NOTE

Highlighted areas indicate the motor input flange available on each gearbox size.

B/BS = Metal shaft sleeve.



* = The service factor (sf) has to be selected depending on application: please contact our Technical Department.

Before selecting any gearbox, please read the performance values shown in the tables on page C8 to C11.

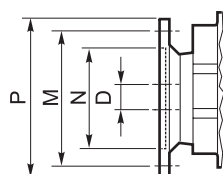



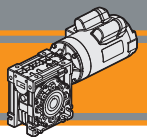

Dimensiones NEMA/ NEMA Dimensions				
	56 C	140 TC	180 TC	210 TC
N	4.5		8.5	
M	5.88		7.25	
P	6.5		9	
D	0.625	0.875	1.125	1.375







Datos técnicos

Technical data

P ₁ [hp]	n ₂ [rpm]	M ₂ [lb·in]	sf	AGMA	i			
0.16 hp								
0.12 kW (1750 rpm)	350	25	14.3	III	5	CM040	56C	
	233	37	10.5	III	7.5		56C	
	175	48	8.2	III	10		56C	
	117	70	5.7	III	15		56C	
	88	90	3.9	III	20		56C	
	70	107	3.2	III	25		56C	
	58	121	3.5	III	30		56C	
	44	150	2.5	III	40		56C	
	35	173	2.0	II	50		56C	
	29	201	1.6	II	60		56C	
	22	240	1.2	I	80		56C	
	18	265	1.0	I	100		56C	
	350	26	25.9	III	5		CM050	56C
	233	38	18.6	III	7.5			56C
	175	49	14.8	III	10			56C
	117	71	10.2	III	15			56C
	88	91	7.0	III	20			56C
	70	110	5.7	III	25			56C
58	125	6.3	III	30	56C			
44	155	4.4	III	40	56C			
35	182	3.5	III	50	56C			
29	208	2.9	III	60	56C			
22	249	2.1	III	80	56C			
18	283	1.8	II	100	56C			
35	190	6.3	III	50	CM063	56C		
29	218	5.1	III	60		56C		
22	263	4.0	III	80		56C		
18	300	3.4	III	100		56C		

P ₁ [hp]	n ₂ [rpm]	M ₂ [lb·in]	sf	AGMA	i			
0.25 hp								
0.18 kW (1750 rpm)	350	40	9.2	III	5	CM040	56C	
	233	58	6.7	III	7.5		56C	
	175	76	5.3	III	10		56C	
	117	109	3.6	III	15		56C	
	88	141	2.5	III	20		56C	
	70	167	2.0	III	25		56C	
	58	189	2.2	III	30		56C	
	44	234	1.6	II	40		56C	
	35	270	1.3	I	50		56C	
	29	314	1.0	I	60		56C	
	350	40	16.6	III	5		CM050	56C
	233	59	11.9	III	7.5			56C
	175	77	9.5	III	10			56C
	117	111	6.5	III	15			56C
	88	142	4.5	III	20			56C
	70	171	3.6	III	25			56C
	58	195	4.0	III	30			56C
	44	241	2.8	III	40			56C
35	284	2.2	III	50	56C			
29	324	1.9	II	60	56C			
22	389	1.4	I	80	56C			
18	442	1.1	I	100	56C			

P ₁ [hp]	n ₂ [rpm]	M ₂ [lb·in]	sf	AGMA	i				
0.25 hp									
0.18 kW (1750 rpm)	35	297	4.0	III	50	CM063	56C		
	29	341	3.3	III	60		56C		
	22	411	2.5	III	80		56C		
	18	469	2.2	III	100		56C		
	0.33 hp								
	0.22 kW (1750 rpm)	350	52	6.9	III		5	CM040	56C
233		77	5.1	III	7.5	56C			
175		100	4.0	III	10	56C			
117		145	2.8	III	15	56C			
88		186	1.9	II	20	56C			
70		220	1.5	II	25	56C			
58		250	1.7	II	30	56C			
44		309	1.2	I	40	56C			
35		357	1.0	I	50	56C			
350		53	12.5	III	5	CM050	56C		
233		78	9.0	III	7.5		56C		
175		101	7.2	III	10		56C		
117		146	5.0	III	15		56C		
88		188	3.4	III	20		56C		
70		226	2.7	III	25		56C		
58		257	3.0	III	30		56C		
44		319	2.1	III	40		56C		
35		375	1.7	II	50		56C		
29	428	1.4	II	60	56C				
22	514	1.0	I	80	56C				
18	583	0.9	I	100	56C				
35	393	3.1	III	50	CM063		56C		
29	450	2.5	III	60			56C		
22	542	1.9	II	80			56C		
18	619	1.7	II	100			56C		
22	571	3.0	III	80			CM075	56C	
18	666	2.4	III	100				56C	

P ₁ [hp]	n ₂ [rpm]	M ₂ [lb·in]	sf	AGMA	i		
0.5 hp							
0.37 kW (1750 rpm)	350	79	4.6	III	5	CM040	56C
	233	116	3.4	III	7.5		56C
	175	151	2.6	III	10		56C
	117	219	1.8	II	15		56C
	88	281	1.3	I	20		56C
	70	333	1.0	I	25		56C
58	378	1.1	I	30	56C		

CM

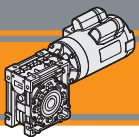





CM

Motorreductores sinfín corona
Wormgearboxes

Nema 60 Hz

Datos técnicos



Technical data

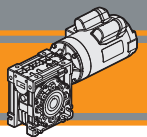

P ₁ [hp]	n ₂ [rpm]	M ₂ [lb·in]	sf	AGMA	i			P ₁ [hp]	n ₂ [rpm]	M ₂ [lb·in]	sf	AGMA	i				
0.5 hp								1 hp									
0.37 kW (1750 rpm)	350	80	8.3	III	5	CM050	56C	0.75 kW (1750 rpm)	350	160	4.1	III	5	CM050	56C		
	233	118	5.9	III	7.5				56C	233	235	3.0	III			7.5	56C
	175	153	4.7	III	10				56C	175	306	2.4	III			10	56C
	117	222	3.3	III	15				56C	117	443	1.6	II			15	56C
	88	285	2.2	III	20				56C	88	570	1.1	I			20	56C
	70	342	1.8	II	25				56C	70	685	0.9	I			25	56C
	58	389	2.0	III	30	56C	58		779	1.0	I	30	56C				
	44	483	1.4	I	40	56C	350 233 175 117 88 70 58 44 35		162	7.3	III	5	CM063	56C-140TC			
	35	568	1.1	I	50	56C			238	5.4	III	7.5			56C-140TC		
	29	649	0.9	I	60	56C			310	4.2	III	10			56C-140TC		
	44	505	2.5	III	40	CM063			56C	454	3.0	III			15	56C-140TC	
	35	595	2.0	III	50				56C	584	2.1	III			20	56C-140TC	
	29	681	1.6	II	60				56C	703	1.7	II			25	56C-140TC	
	22	822	1.3	I	80		56C		811	1.8	II	30	56C-140TC				
	18	937	1.1	I	100		56C		1009	1.2	I	40	56C				
	29	714	2.7	III	60		CM075		56C	1189	1.0	I	50	56C			
	22	865	2.0	II	80	56C			70 58 44 35 29 22	721	2.8	III	25	CM075	56C-140TC		
	18	1009	1.6	II	100	56C				833	3.1	III	30			56C-140TC	
22	923	3.1	III	80	CM090	56C		1053		2.1	III	40	56C-140TC				
18	1081	2.4	III	100		56C		1244		1.6	II	50	56C-140TC				
								56C		1427	1.4	I	60			56C	
							56C	1730		1.0	I	80	56C				
								35 29 22 18	1298	2.6	III	50	CM090	56C-140TC			
									1492	2.1	III	60			56C-140TC		
							1845		1.6	II	80	56C					
							2163		1.2	I	100	56C					
							22 18		1961	2.5	III	80			CM110	140TC	
									2307	2.0	III	100					140TC
0.75 hp								1.5 hp									
0.55 kW (1750 rpm)	350	120	5.5	III	5	CM050	56C	1.1 kW (1750 rpm)	350	243	4.9	III	5	CM063	56C-140TC		
	233	176	4.0	III	7.5				56C	233	357	3.6	III			7.5	56C-140TC
	175	230	3.2	III	10				56C	175	465	2.8	III			10	56C-140TC
	117	333	2.2	III	15				56C	117	681	2.0	III			15	56C-140TC
	88	427	1.5	II	20				56C	88	876	1.4	I			20	56C-140TC
	70	514	1.2	I	25				56C	70	1054	1.1	I			25	56C-140TC
	58	584	1.3	I	30	56C	58		1217	1.2	I	30	56C-140TC				
	44	724	0.9	I	40	56C	58		1217	1.2	I	30	56C-140TC				
	88	438	2.7	III	20	CM063	56C		233 175 117 88 70 58 58	361	5.8	III	7.5	CM075	56C-140TC		
	70	527	2.3	III	25		56C			470	4.8	III	10			56C-140TC	
	58	608	2.4	III	30		56C			681	3.5	III	15			56C-140TC	
	44	757	1.7	II	40		56C			898	2.4	III	20			56C-140TC	
	35	892	1.3	I	50		56C			1081	1.8	II	25			56C-140TC	
	29	1022	1.1	I	60		56C			1249	2.0	III	30			56C-140TC	
	22	1233	0.8	I	80	56C	44 35 29		1579	1.4	II	40	CM075	56C-140TC			
	58	624	4.1	III	30	CM075			56C	1865	1.1	I			50	56C-140TC	
	44	789	2.8	III	40				56C	2141	0.9	I			60	56C	
	35	933	2.2	III	50				56C								
29	1071	1.8	II	60	56C												
22	1298	1.3	I	80	56C												
18	1514	1.1	I	100	56C												
29	1119	2.8	III	60	CM090	56C											
22	1384	2.1	III	80		56C											
18	1622	1.6	II	100		56C											







Datos técnicos



Technical data



P ₁ [hp]	n ₂ [rpm]	M ₂ [lb·in]	sf	AGMA	i		
1.5 hp							
1.1 kW (1750 rpm)	44	1644	2.3	III	40	CM090	56C-140TC
	35	1946	1.8	II	50		56C-140TC
	29	2238	1.4	I	60		56C-140TC
	22	2768	1.0	I	80		56C
	35	2055	3.0	III	50	CM110	140TC
	29	2368	2.3	III	60		140TC
	22	2941	1.7	II	80		140TC
	18	3460	1.3	I	100		140TC

P ₁ [hp]	n ₂ [rpm]	M ₂ [lb·in]	sf	AGMA	i		
3 hp							
2.2 kW (1750 rpm)	233	730	4.1	III	7.5	CM090	140TC-180TC
	175	952	3.5	III	10		140TC-180TC
	117	1395	2.7	III	15		140TC-180TC
	88	1817	2.0	III	20		140TC-180TC
	70	2244	1.5	II	25		140TC-180TC
	58	2563	1.7	II	30		140TC-180TC
	44	3287	1.2	I	40		140TC
	35	3893	0.9	I	50		140TC
	70	2271	2.6	III	25	CM110	140TC-180TC
	58	2595	2.8	III	30		140TC-180TC
	44	3417	2.0	II	40		140TC-180TC
	35	4109	1.5	II	50		140TC-180TC
	29	4736	1.2	I	60		140TC-180TC
	22	5882	0.8	I	80		140TC-180TC

P ₁ [hp]	n ₂ [rpm]	M ₂ [lb·in]	sf	AGMA	i				
2 hp									
1.5 kW (1750 rpm)	350	324	3.7	III	5	CM063	56C-140TC		
	233	476	2.7	III	7.5		56C-140TC		
	175	620	2.1	III	10		56C-140TC		
	117	908	1.5	II	15		56C-140TC		
	88	1168	1.0	I	20		56C-140TC		
	70	1406	0.8	I	25		56C-140TC		
	58	1622	0.9	I	30		56C-140TC		
		233	481	4.4	III		7.5	CM075	56C-140TC
		175	627	3.6	III		10		56C-140TC
		117	908	2.6	III		15		56C-140TC
		88	1197	1.8	II		20		56C-140TC
		70	1442	1.4	I		25		56C-140TC
	58	1665	1.5	II	30	56C-140TC			
	44	2105	1.1	I	40	56C-140TC			
	88	1211	3.0	III	20	CM090	56C-140TC		
	70	1496	2.2	III	25		56C-140TC		
	58	1709	2.6	III	30		56C-140TC		
	44	2192	1.8	II	40		56C-140TC		
	35	2595	1.3	I	50		56C-140TC		
	29	2984	1.0	I	60		56C-140TC		
	44	2278	3.0	III	40	CM110	140TC		
	35	2739	2.3	III	50		140TC		
	29	3158	1.8	II	60		140TC		
	22	3922	1.3	I	80		140TC		
	18	4614	1.0	I	100		140TC		

P ₁ [hp]	n ₂ [rpm]	M ₂ [lb·in]	sf	AGMA	i		
5 hp							
3.7 kW (1750 rpm)	233	1203	1.8	II	7.5	CM075	180TC
	175	1568	1.5	II	10		180TC
	117	2271	1.0	I	15		180TC
	233	1217	2.5	III	7.5	CM090	180TC
	175	1586	2.1	III	10		180TC
	117	2325	1.6	II	15		180TC
	88	3028	1.2	I	20		180TC
	70	3740	0.9	I	25		180TC
	58	4271	1.0	I	30		180TC
	233	1203	4.5	III	7.5	CM110	180TC
	175	1586	3.7	III	10		180TC
	117	2325	2.8	III	15		180TC
	88	3064	2.1	III	20		180TC
	70	3785	1.6	II	25		180TC
	58	4325	1.7	II	30		180TC
	44	5695	1.2	I	40		180TC
	35	6848	0.9	I	50		180TC

P ₁ [hp]	n ₂ [rpm]	M ₂ [lb·in]	sf	AGMA	i		
3 hp							
2.2 kW (1750 rpm)	350	487	2.4	III	5	CM063	140TC
	233	714	1.8	II	7.5		140TC
	175	930	1.4	II	10		140TC
	117	1362	1.0	I	15		140TC
	233	722	2.9	III	7.5	CM075	140TC-180TC
	175	941	2.4	III	10		140TC-180TC
	117	1362	1.7	II	15		140TC-180TC
	88	1795	1.2	I	20		140TC
	70	2163	0.9	I	25		140TC
	58	2498	1.0	I	30		140TC

P ₁ [hp]	n ₂ [rpm]	M ₂ [lb·in]	sf	AGMA	i		
7.5 hp							
5.5 kW (1750 rpm)	233	1804	3.0	III	7.5	CM110	210TC
	175	2379	2.5	III	10		210TC
	117	3487	1.9	II	15		210TC
	88	4596	1.4	II	20		210TC
	233	2406	2.2	III	7.5	CM110	210TC
	175	3172	1.9	II	10		210TC
	117	4650	1.4	I	15		210TC
	88	6128	1.1	I	20		210TC

CM

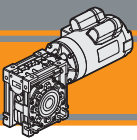

CM

Motorreductores sinfín corona
Wormgearboxes

Nema 60 Hz

Dimensiones

Dimensions

CM 040 U - CMIS 040 U

CM 040 U

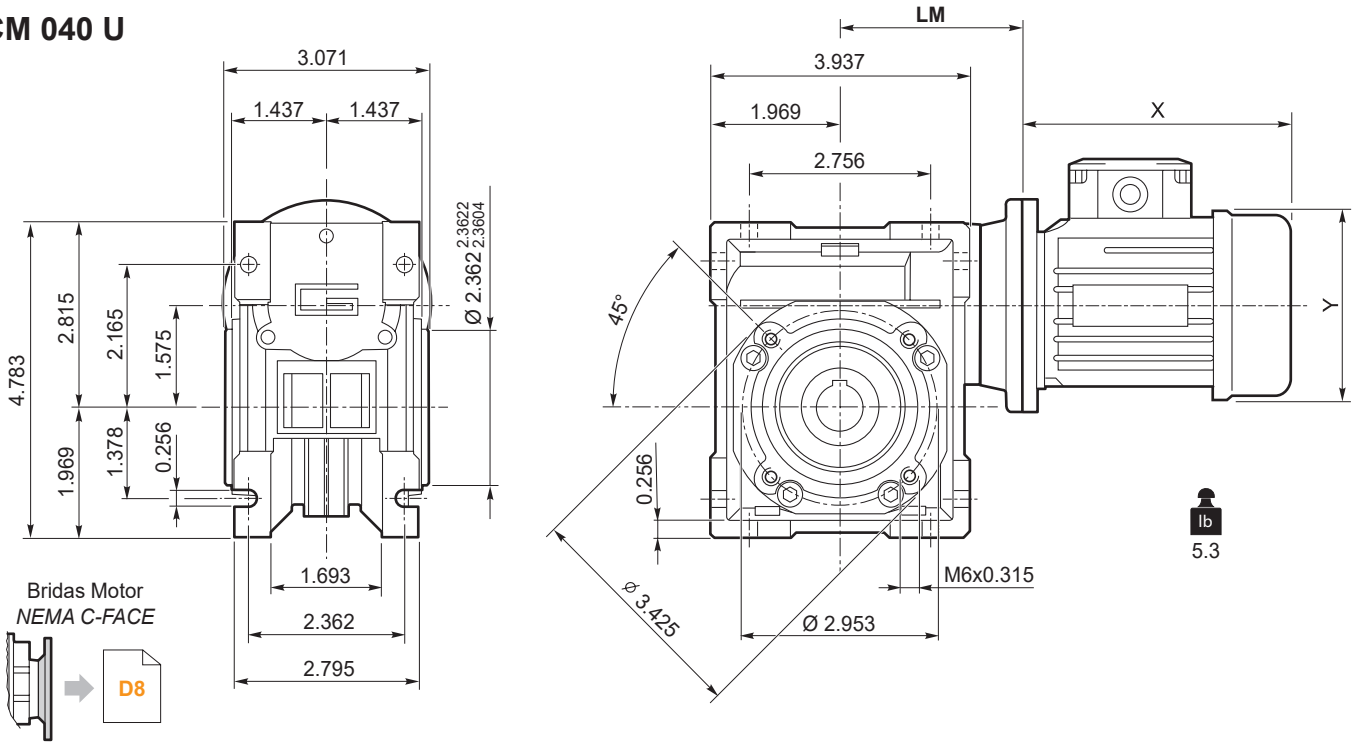

CMIS 040 ..

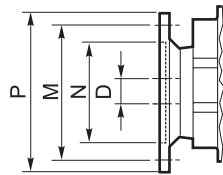
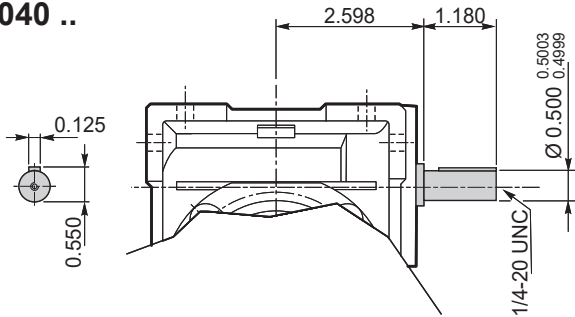

Brida Motor / Motor flange	
Dimensiones NEMA NEMA Dimensions	
	56 C
N	4.5
M	5.88
P	6.5
D	0.625
LM	3.150

Eje de salida hueco / Hollow output shaft

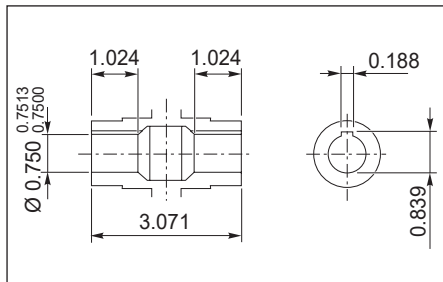

Eje de salida / Output shaft

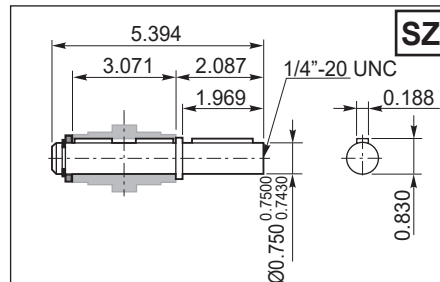

Eje de salida / Output shaft

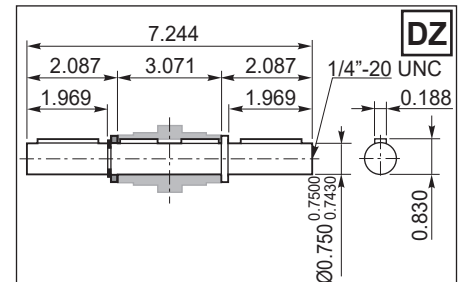

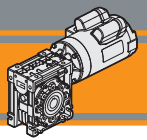

Dimensiones

Dimensions

CM 040 F..

CM 040 F

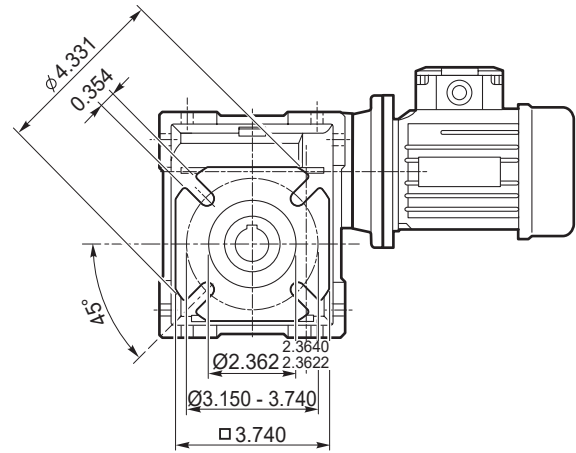
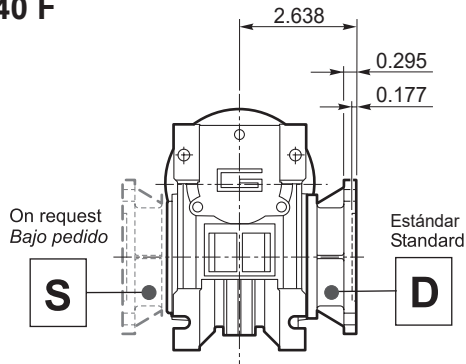

CM 040 FB

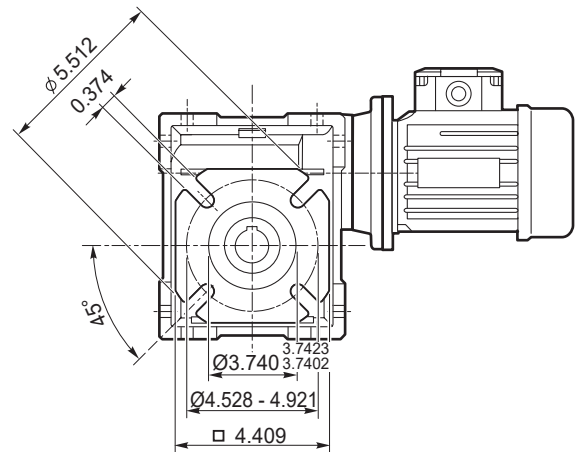
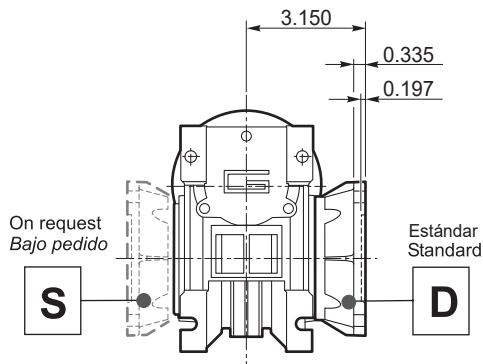

CM 040 FL

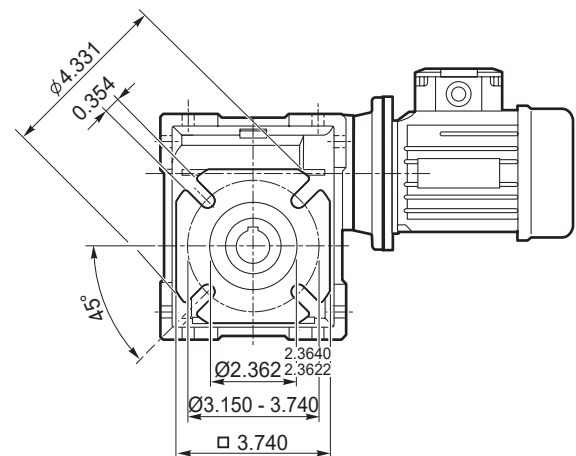
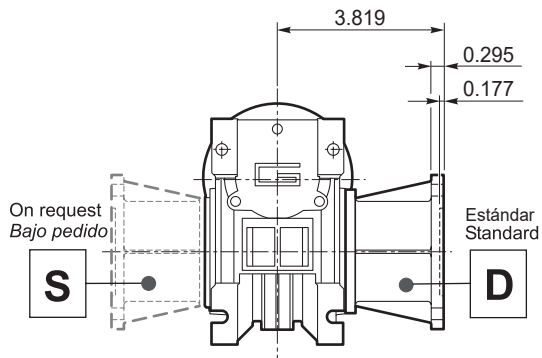

CM

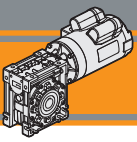

CM

Motorreductores sinfín corona
Wormgearboxes

Nema 60 Hz

Dimensiones

Dimensions

CM 050 U - CMIS 050 U

CM 050 U

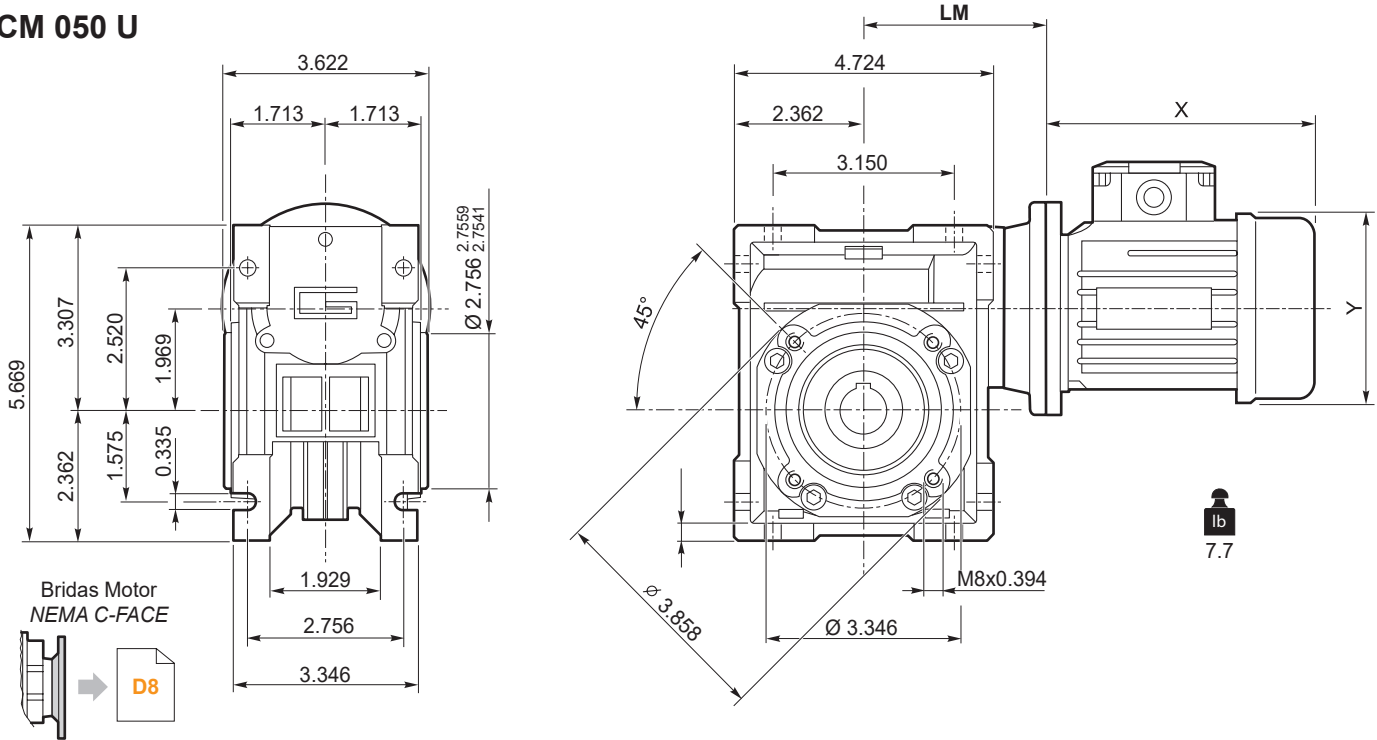

Bridas Motor
NEMA C-FACE

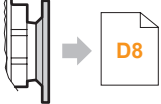

CMIS 050 ..

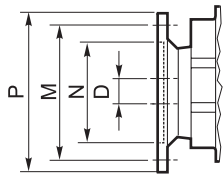
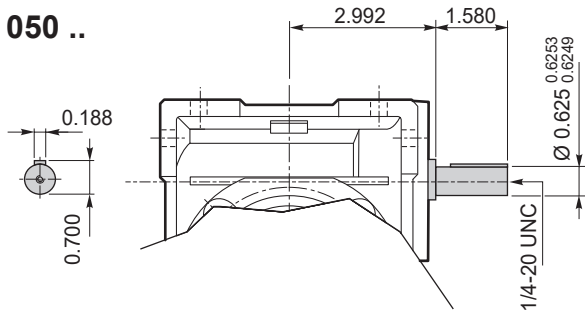

Brida Motor / Motor flange	
Dimensiones NEMA NEMA Dimensions	
	56 C
N	4.5
M	5.88
P	6.5
D	0.625
LM	3.346

Eje de salida hueco / Hollow output shaft

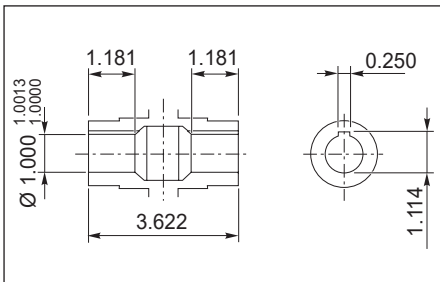

Eje de salida / Output shaft

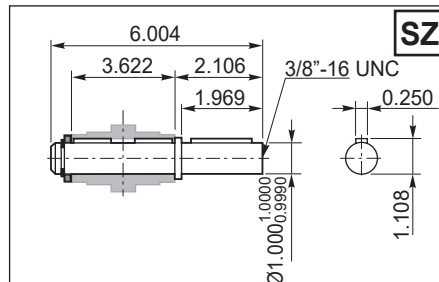

Eje de salida / Output shaft

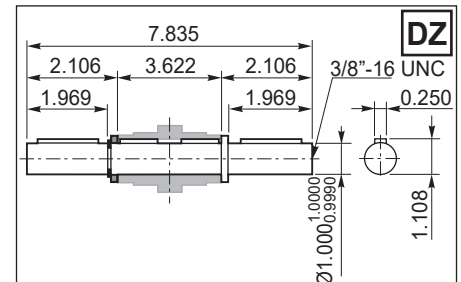

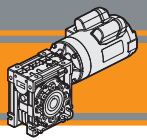

Dimensiones

Dimensions

CM 050 F..

CM 050 F

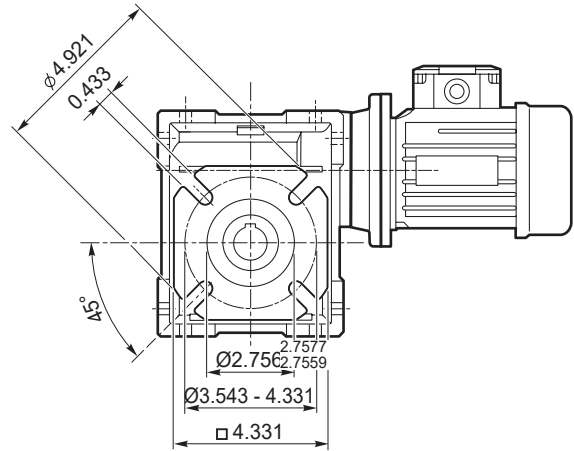
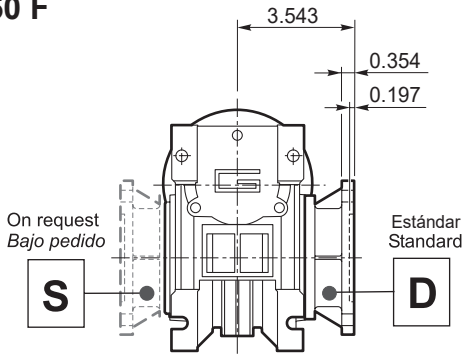

CM 050 FB

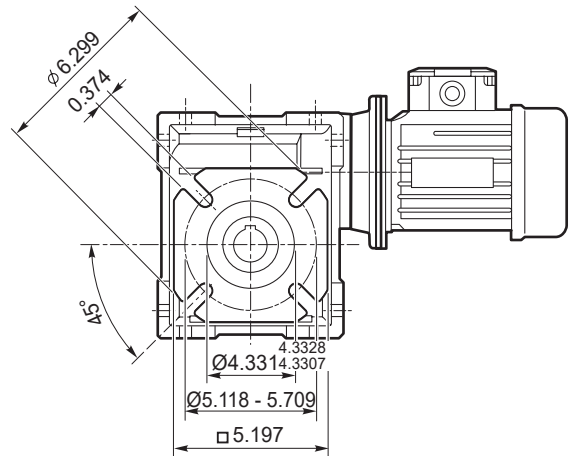
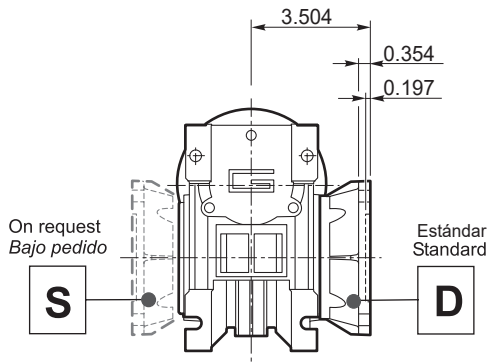

CM 050 FL

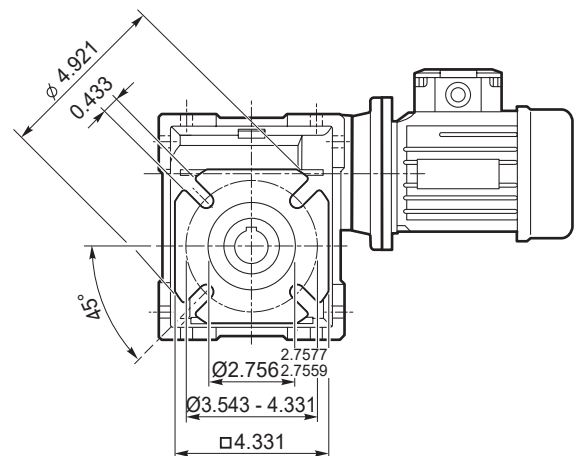
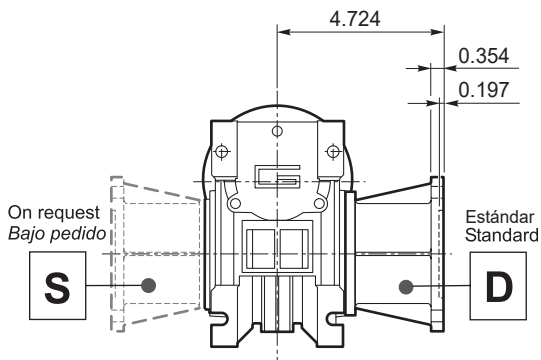

CM

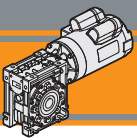

CM

Motorreductores sinfín corona
Wormgearboxes

Nema 60 Hz

Dimensiones

Dimensions

CM 063 U - CMIS 063 U

CM 063 U

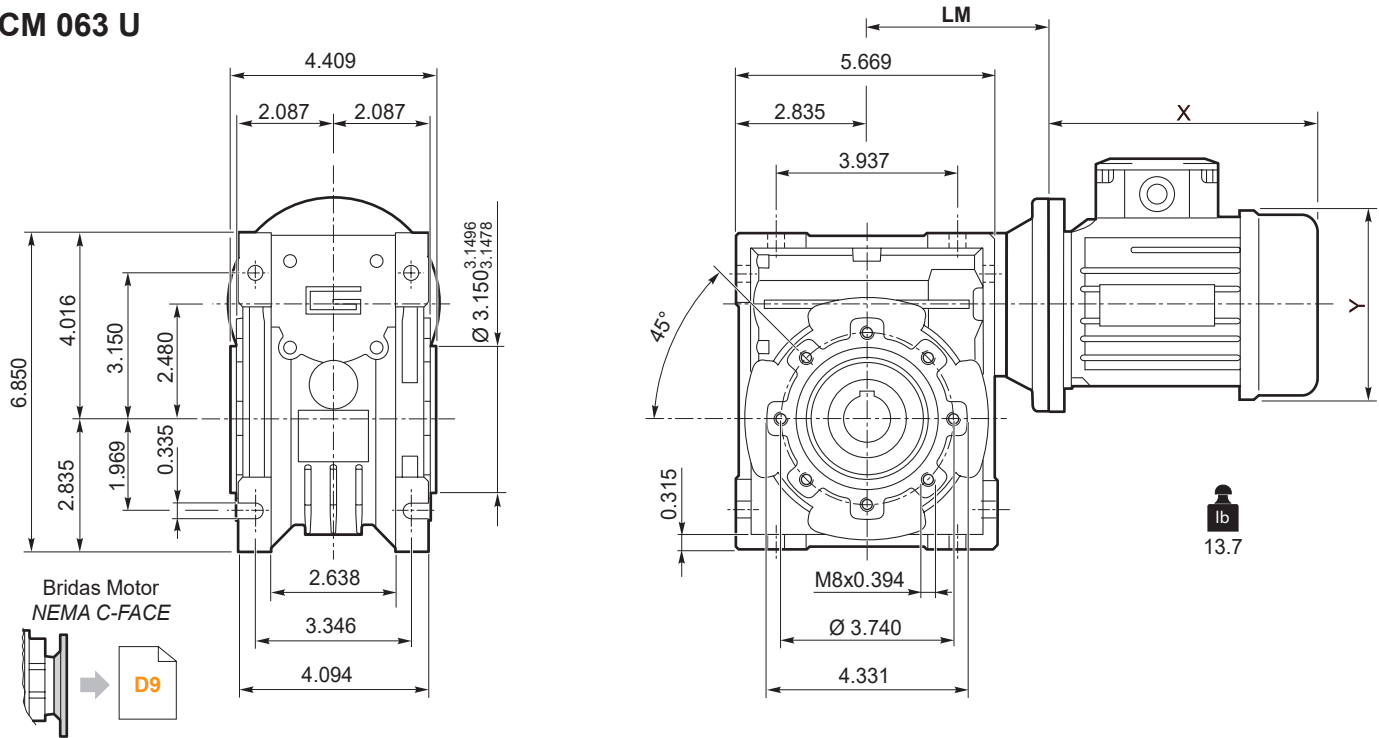

CMIS 063 ..

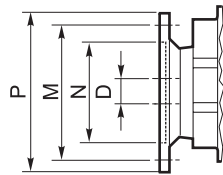
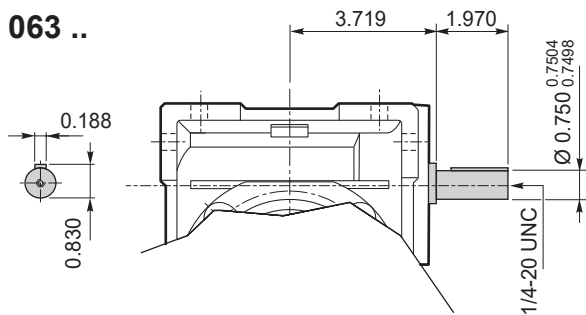

Brida Motor / Motor flange		
Dimensiones NEMA NEMA Dimensions		
	56 C	140 TC
N		4.5
M		5.88
P		6.5
D	0.625	0.875
LM	4.055	

Eje de salida hueco / Hollow output shaft

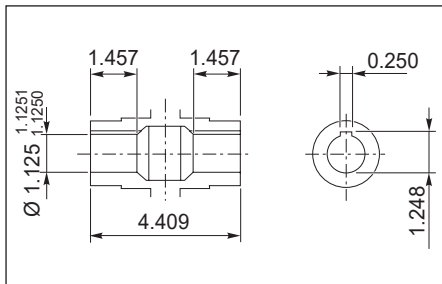

Eje de salida / Output shaft

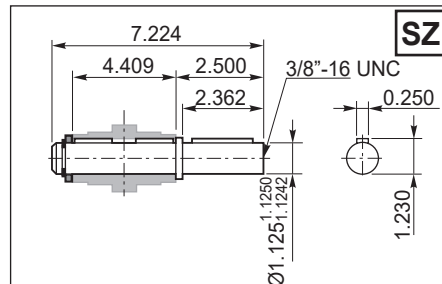

Eje de salida / Output shaft

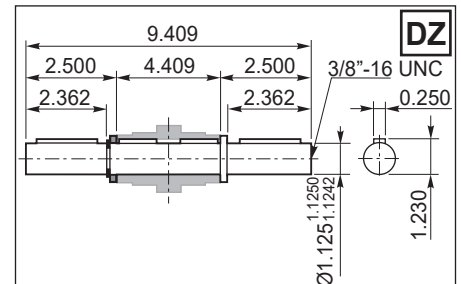

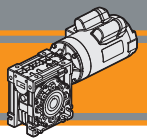

Dimensiones

Dimensions

CM 063 F..

CM 063 F

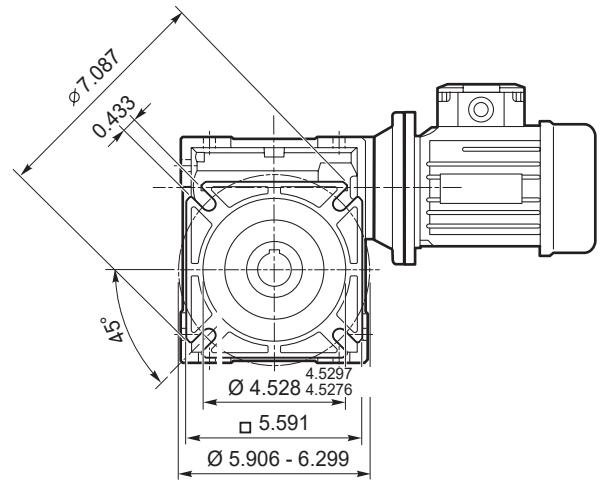
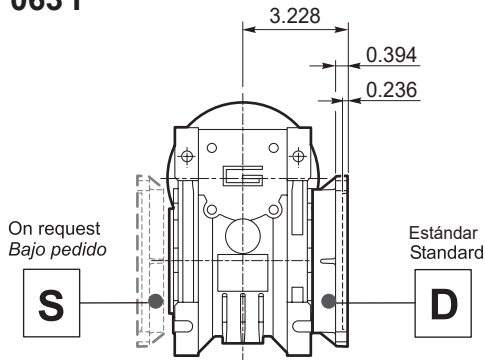

CM 063 FB

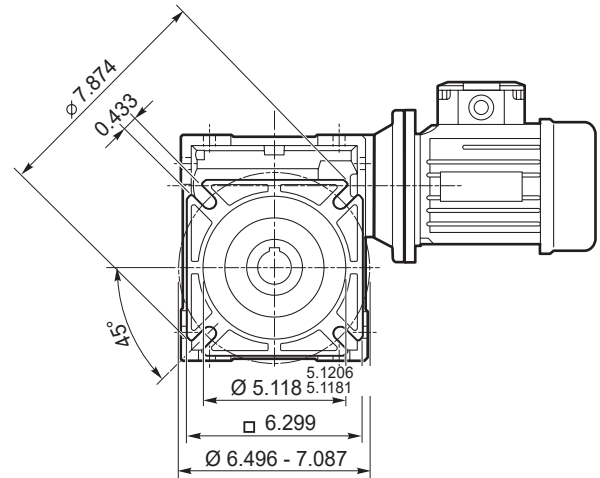
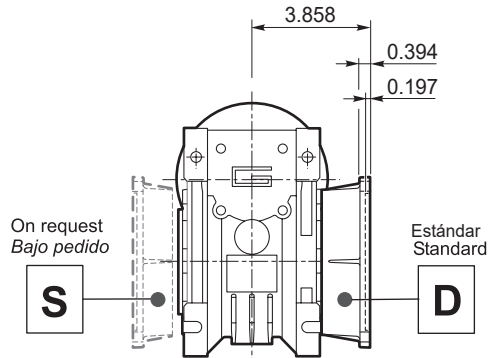

CM 063 FL

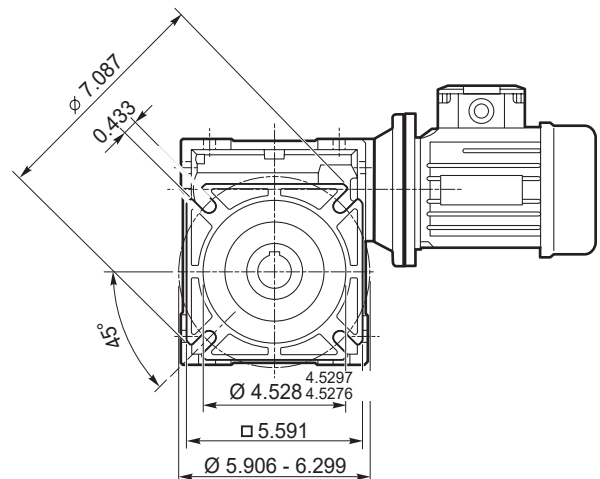
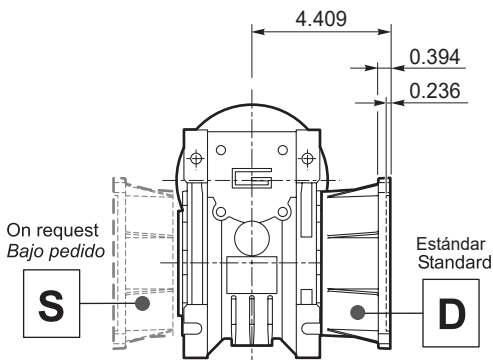

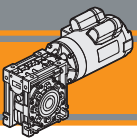

CM

Motorreductores sinfín corona
Wormgearboxes

Nema 60 Hz

Dimensiones

Dimensions

CM 075 U - CMIS 075 U

CM 075 U

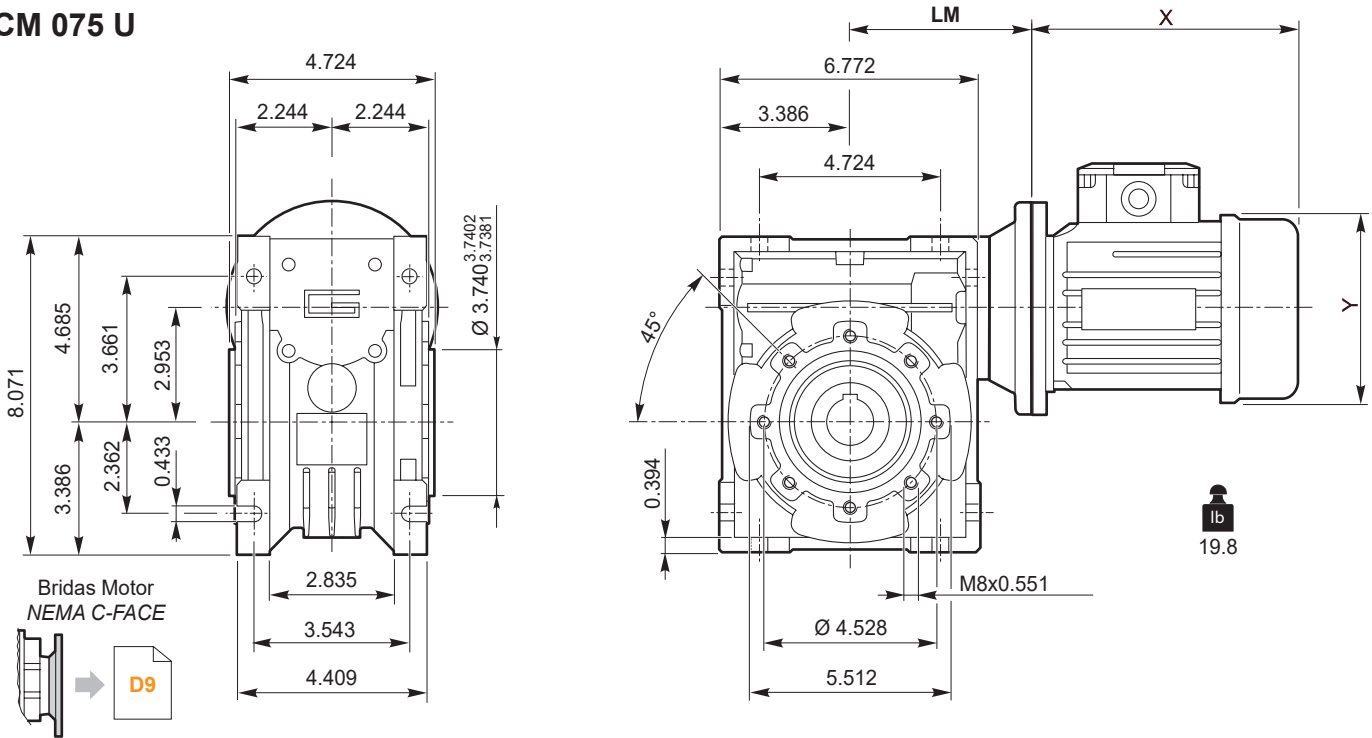

CMIS 075 ..

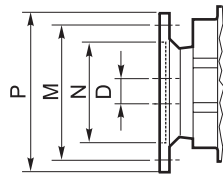
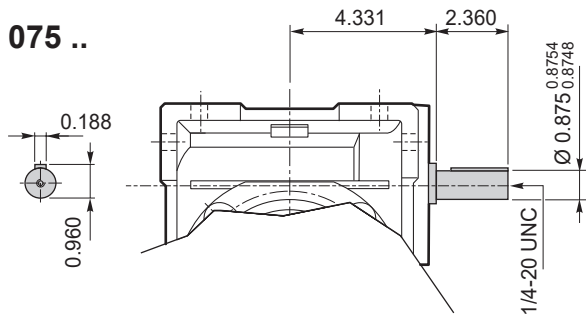

Brida Motor / Motor flange			
Dimensiones NEMA NEMA Dimensions			
	56 C	140 TC	180 TC
N	4.5		8.5
M	5.88		7.25
P	6.5		9
D	0.625	0.875	1.125
LM	4.842		4.961

Eje de salida hueco / Hollow output shaft

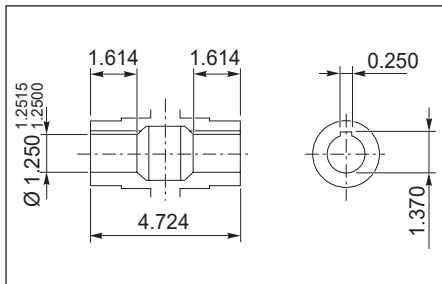

Eje de salida / Output shaft

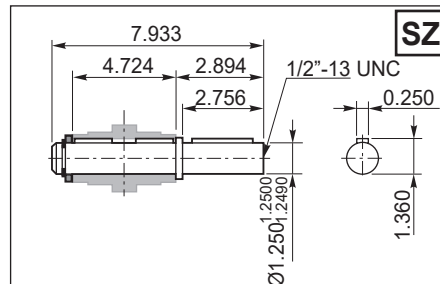

Eje de salida / Output shaft

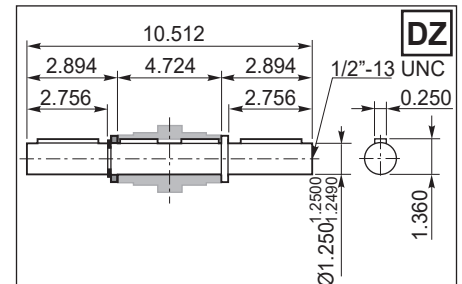

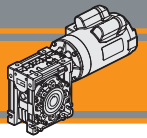

Dimensiones

Dimensions

CM 075 F..

CM 075 F

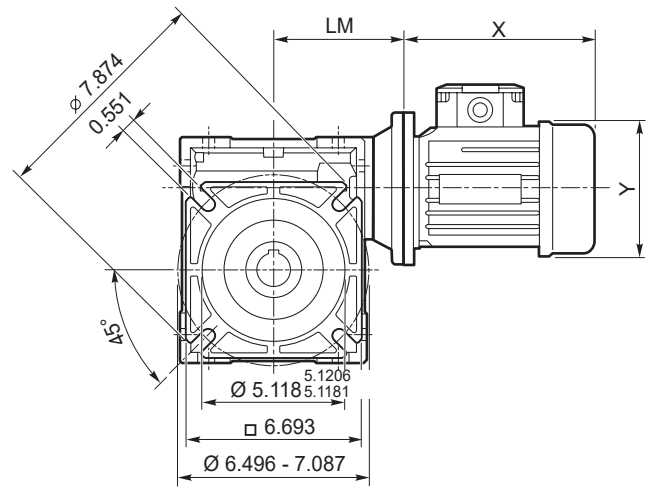
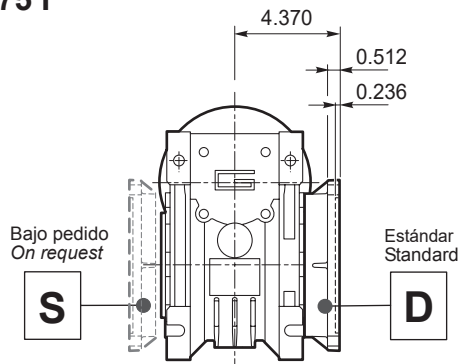

CM

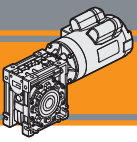

CM

Motorreductores sinfín corona
Wormgearboxes

Nema 60 Hz

Dimensiones

Dimensions

CM 090 U - CMIS 090 U

CM 090 U

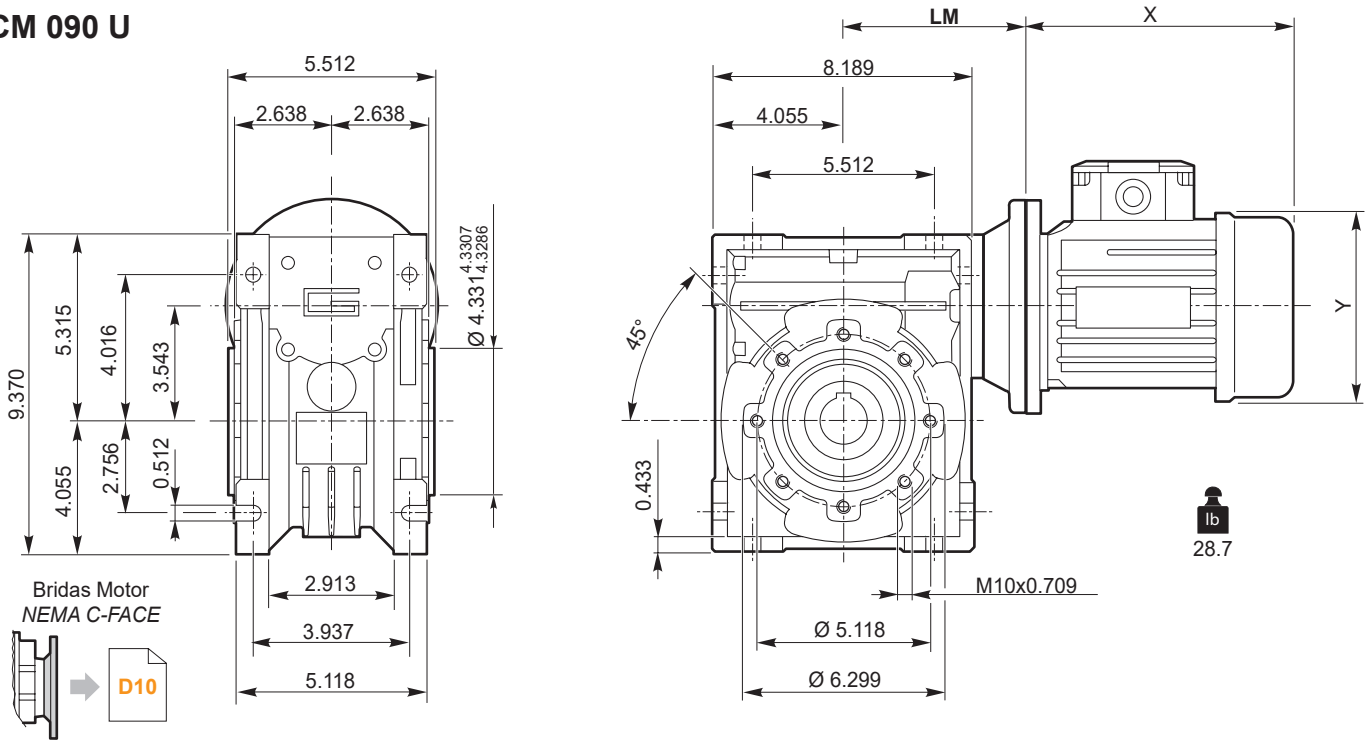

CMIS 090 ..

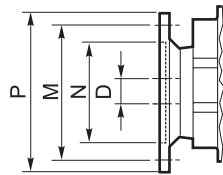
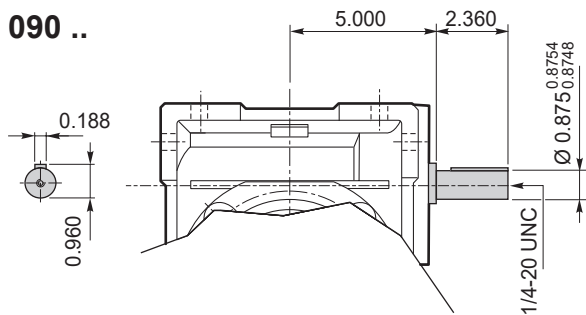

Brida Motor / Motor flange			
Dimensiones NEMA NEMA Dimensions			
	56 C	140 TC	180 TC
N	4.5	8.5	
M	5.88	7.25	
P	6.5	9	
D	0.625	0.875	1.125
LM	5.512		5.419

Eje de salida hueco / Hollow output shaft

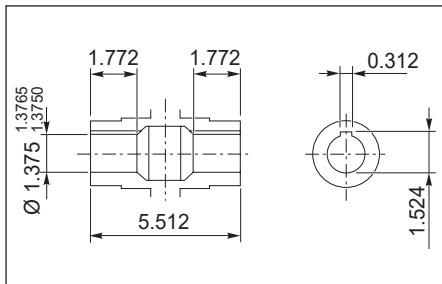

Eje de salida / Output shaft

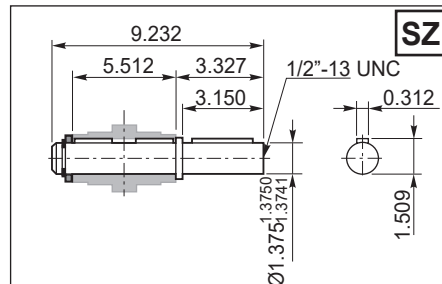

Eje de salida / Output shaft

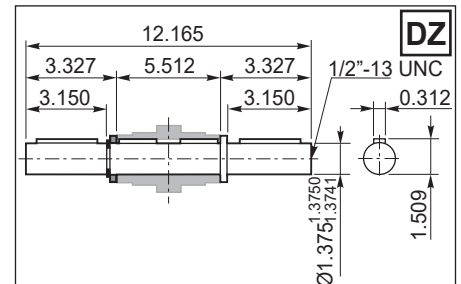

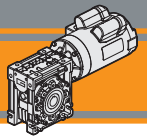

Dimensiones

Dimensions

CM 090 F..

CM 090 F

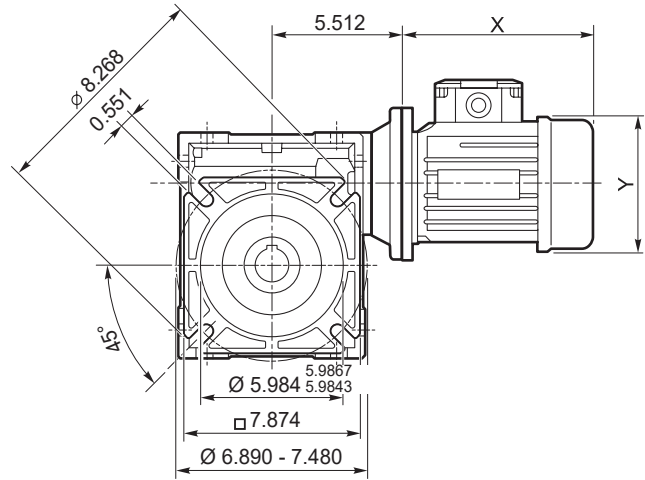
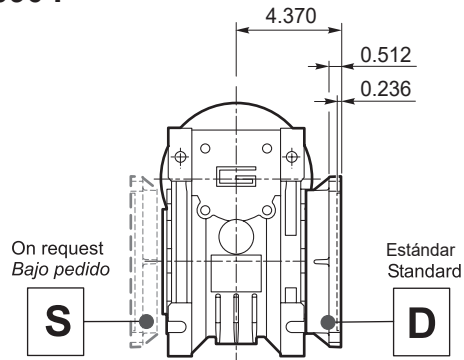

CM

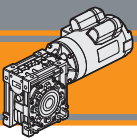

CM

Motorreductores sinfín corona
Wormgearboxes

Nema 60 Hz

Dimensiones

Dimensions

CM 110 U - CMIS 110 U

CM 110 U

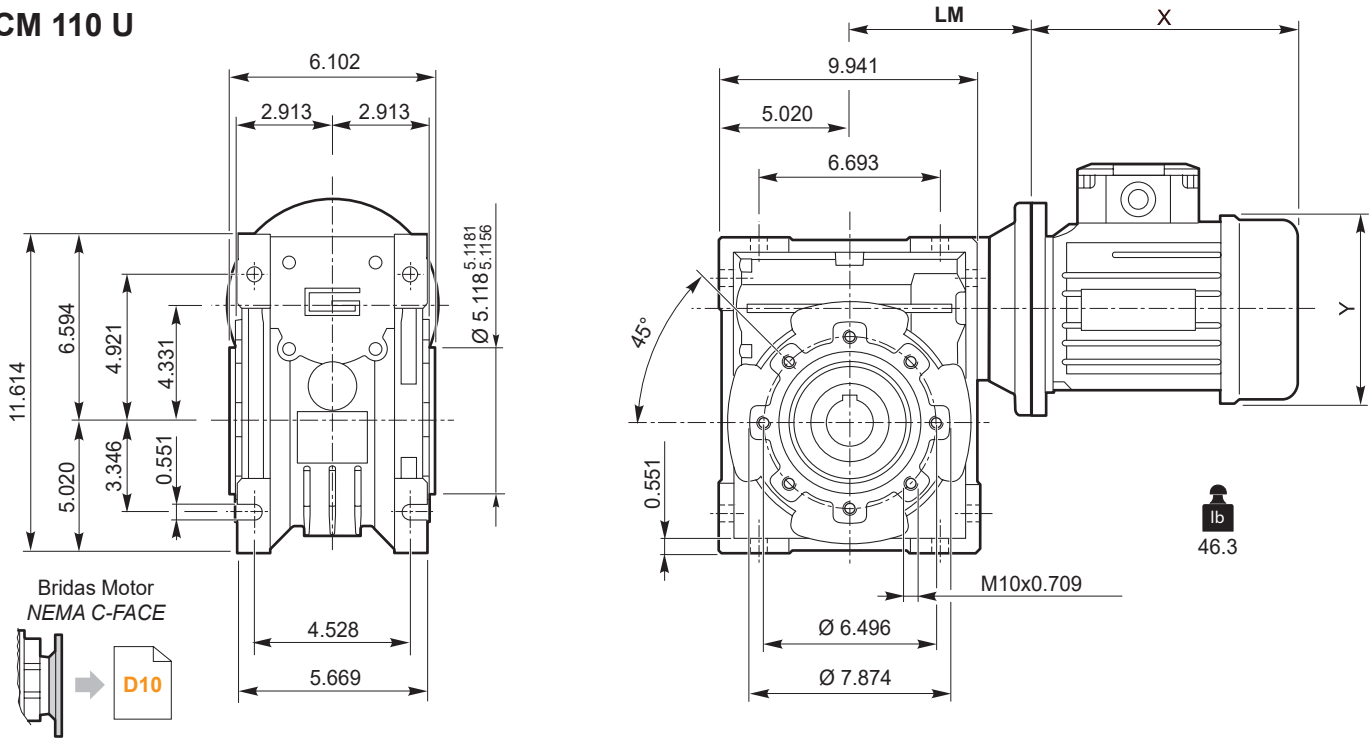

CMIS 110 ..

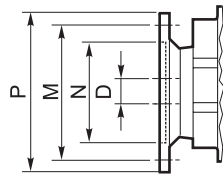
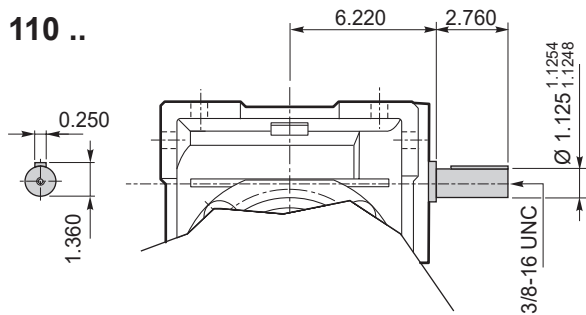

Brida Motor / Motor flange			
Dimensiones NEMA			
NEMA Dimensions			
	140 TC	180 TC	210 TC
N	4.5	8.5	
M	5.88	7.25	
P	6.5	9	
D	0.875	1.125	1.375
LM	6.693	6.693	

Eje de salida hueco / Hollow output shaft

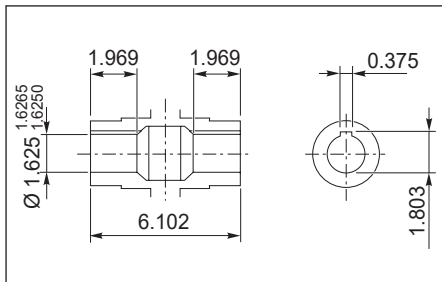

Eje de salida / Output shaft

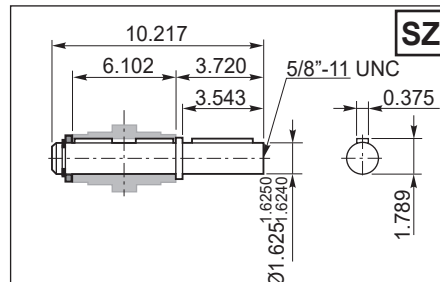

Eje de salida / Output shaft

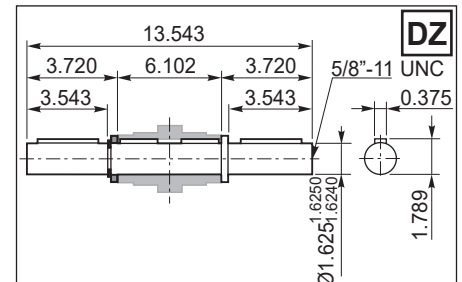

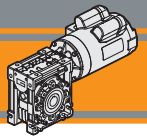

Dimensiones

Dimensions

CM 110 F..

CM 110 F

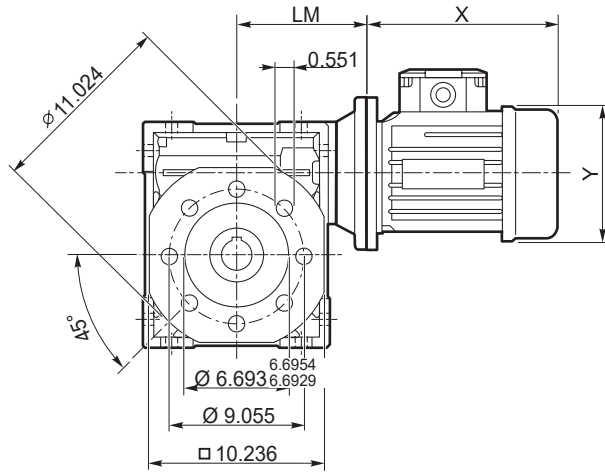
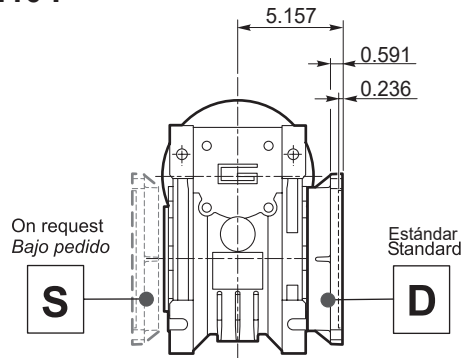

CM

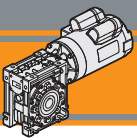

CM

Motorreductores sin fin corona
Wormgearboxes

Nema 60 Hz

Accesorios

Accessories

Eje de salida simple y doble

Single and double output shaft

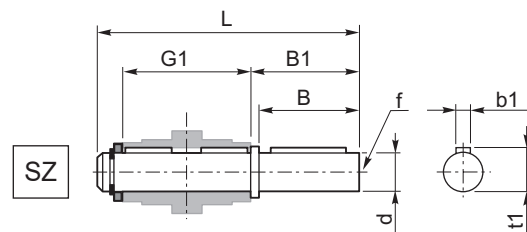
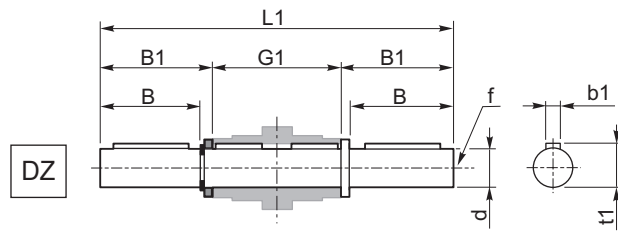

CM	d	B	B1	G1	L	L1	f	b1	t1
040	0.750 0.7500 0.7430	1.969	2.087	3.071	5.394	7.244	1/4"-20	0.188	0.830
050	1.000 1.0000 0.9992	1.969	2.106	3.622	6.004	7.835	3/8"-16	0.250	1.108
063	1.125 1.1250 1.1242	2.362	2.500	4.409	7.224	9.409	3/8"-16	0.250	1.230
075	1.250 1.2500 1.2490	2.756	2.894	4.724	7.933	10.512	1/2"-13	0.250	1.360
090	1.375 1.3750 1.3741	3.150	3.327	5.512	9.232	12.165	1/2"-13	0.312	1.509
110	1.625 1.6250 1.6240	3.543	3.720	6.102	10.217	13.543	5/8"-11	0.375	1.789

Brazo de reacción

Torque arm

CM	K1	G	KG	KH	R
040	3.937	0.551	1.220	0.394	0.709
050	3.937	0.551	1.496	0.394	0.709
063	5.906	0.551	1.870	0.394	0.709
075	7.874	0.984	1.831	0.787	1.181
090	7.874	0.984	2.224	0.787	1.181
110	9.843	1.181	2.441	0.984	1.378

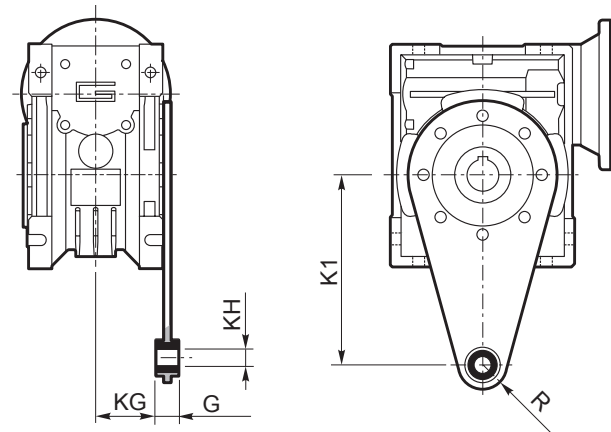

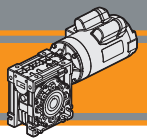

Opciones

Options

SC - Cubierta de seguridad - Safety Cover

CM	M
040	2.14
050	2.46
063	2.87
075	3.11
090	3.70
110	4.02

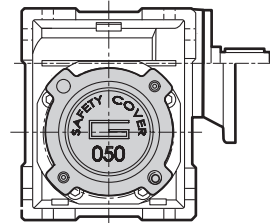
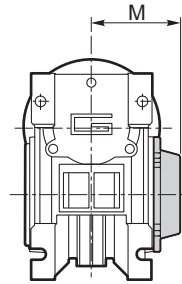

WD - Kit washdown cover

CM	M
040	2.19
050	2.50
063	2.81
075	3.15
090	3.74
110	4.06

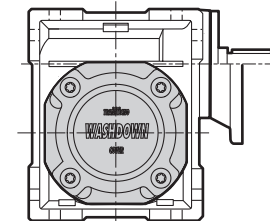
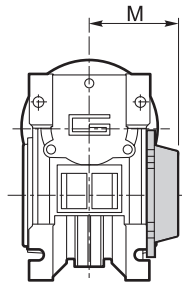

 **TRANSTECNO SRL**
HEADQUARTERS
Via Caduti di Sabbiano, 11/D-E
40011 Anzola dell'Emilia (BO)
ITALY
T+39 051 64 25 811
F +39 051 73 49 43
sales@transtecno.com
www.transtecno.com

TRANSTECNO®
the modular gearmotor
MEMBER OF INTERPUMP GROUP

CATALUNYA0920



 **HANGZHOU TRANSTECNO POWER TRANSMISSIONS CO LTD**
No.4 Xiuyan Road Fengdu Industry Zone
Pingyao Town Yuhang District
Hangzhou City, Zhejiang Province
311115 - CHINA
T +86 571 86 92 02 60
F +86 571 86 92 18 10
info-china@transtecno.cn
www.transtecno.cn

 **MA TRANSTECNO S.A.P.I. DE C.V.**
Av. Mundial # 176, Parque Industrial
JM Apodaca, Nuevo León,
C.P. 66600 - MÉXICO
T +52 8113340920
info@transtecno.com.mx
www.transtecno.com.mx

 **TRANSTECNO IBÉRICA**
THE MODULAR GEARMOTOR, S.A.
C/Enginy, 2 Nave 6
08850 Gavà (Barcelona) - SPAIN
T +34 931 598 950
info@transtecno.es
www.transtecno.es

 **TRANSTECNO B.V.**
De Stuwdam,43
3815 KM Amersfoort - NETHERLANDS
T +31(0) 33 45 19 505
F +31(0) 33 45 19 506
info@transtecno.nl
www.transtecno.nl

 **TRANSTECNO AANDRIJFTECHNIEK B.V.**
De Stuwdam 43
3815 KM Amersfoort - NETHERLANDS
T +31 (0) 33 20 4 7 006
info@transtecnoaandrijftechnik.nl
www.transtecnoaandrijftechnik.nl

 **TRANSTECNO USA**
8 Creek Parkway,
Boothwyn PA 19061-8136
UNITED STATES
T + 1 (610) 4970154
F +1 (610) 497 6085
14561 Fryelands Blvd SE
Monroe, WA 98272 - UNITED STATES
T +1 360-863-1300
F +1 360-863-1303
usaoffice@transtecno.com
www.transtecno.com

 **TRANSTECNO CANADA**
51 B Caldari Road Unit 10
Vaughan, ON L4K 4G3 - CANADA
T +1 905 761 0762
F +1 905 761 9265
canadaoffice@transtecno.com
www.transtecno.com

 **TRANSTECNO CHILE-PERU**
Av. Los Libertadores 41
Parque Industrial - Los Libertadores 16.500
Santiago, Colina - CHILE
T +56 2 29633870
Carretera Panamericana Sur KM 29.5,
Interior I-3, Z.I. Lurin - PERU
T +51 1 3546259 / +51 1 3434231
chileoffice@transtecno.com
www.transtecno.com

 **SALES OFFICE BRAZIL**
Rua Dr. Freire Alemão 155 / 402 - CEP. 90450-060
Auxiliadora Porto Alegre RS - BRAZIL
T +55 51 3251 5447
F +55 51 3251 5447
M +55 51 811 45 962
braziloffice@transtecno.com
www.transtecno.com.br

 **SALES OFFICE OCEANIA**
44 Northview drive, Sunshine west 3020
Victoria - AUSTRALIA
T +61 03 9312 4722
F +61 03 9312 4714
M +61 0438060997
oceaniaoffice@transtecno.com
www.transtecno.com.au

 **SALES OFFICE INDIA**
Woodbine 2003/04, Everest World
Kolshet Road, Thane west Mumbai 400607
INDIA
T +91 982 061 46 98
indiaoffice@transtecno.com
www.transtecno.com

 **SALES OFFICE SOUTH KOREA**
410-7. Samrae-eup, Wanju-goon, Chonbuk 55332
SOUTH KOREA
T +82 70 8867 8897
F +82 504 199 2107
M +82 10 5094 2107
koreaoffice@transtecno.com
www.transtecno.com