

**MINI**  **TECNO**™  
**small** but strong

**NDCM**  
**ECM**

Motoriduttori CC a vite senza fine  
DC wormgearmotors

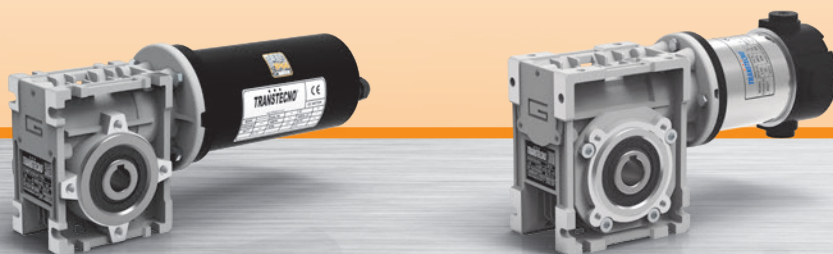

**MINI**  **TECNO**™ brand of  
**TRANSTECNO**®



DC





<b>Indice</b>	<b>Index</b>	Pag. Page
Caratteristiche tecniche	<i>Technical features</i>	<b>BG2</b>
Designazione	<i>Classification</i>	<b>BG2</b>
Simbologia	<i>Symbols</i>	<b>BG3</b>
Lubrificazione	<i>Lubrication</i>	<b>BG3</b>
Carichi radiali	<i>Radial loads</i>	<b>BG3</b>
Dati di dentatura	<i>Toothing data</i>	<b>BG4</b>
Rendimento	<i>Efficiency</i>	<b>BG4</b>
Dati tecnici per servizio S2	<i>Technical data for S2 duty</i>	<b>BG5</b>
Motori applicabili	<i>Motor adapters</i>	<b>BG8</b>
Dimensioni	<i>Dimensions</i>	<b>BG8</b>
Opzioni	<i>Options</i>	<b>BG23</b>
Accessori	<i>Accessories</i>	<b>BG23</b>

Questa sezione annulla e sostituisce ogni precedente edizione o revisione. Qualora questa sezione non Vi sia giunta in distribuzione controllata, l'aggiornamento dei dati ivi contenuto non è assicurato. **In tal caso la versione più aggiornata è disponibile sul nostro sito internet [www.transtecno.com](http://www.transtecno.com)**

*This section replaces any previous edition and revision. If you obtained this catalogue other than through controlled distribution channels, the most up to date content is not guaranteed. In this case the latest version is available on our web site [www.transtecno.com](http://www.transtecno.com)*

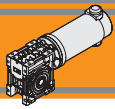

**Caratteristiche tecniche**

**Technical features**

I motoriduttori CC a vite senza fine a magneti permanenti in neodimio **NDCM** e in ferrite **ECM** hanno le seguenti caratteristiche principali:

**NDCM** neodymium permanent magnets and **ECM** ferrite permanent magnets DC wormgearmotors range has the following main features:

- Alimentazione in bassa tensione 12/24 Vcc
- Possibilità di montaggio encoder e freno
- Potenze motore disponibili da 100 a 800 W S2
- Carcasce dei riduttori in pressofusione di alluminio
- Lubrificazione permanente con olio sintetico
- Low voltage power supply 12/24 Vdc
- Suitable for encoder and brake assembly
- Motor power ratings available from 100 to 800 W S2
- Die-cast aluminum housing
- Permanent synthetic oil long life lubrication

**Designazione**

**Classification**

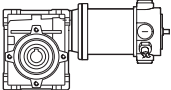
MOTORIDUTTORE / GEARMOTOR									
NDCM	120/030		U	10	SZDX	BRSX	90	240	VS
Tipo Type	Grandezza Size		Versione Riduttore Gearbox Version	Rapporto Ratio	Albero di uscita Output shaft	Braccio di reazione Torque arm	Angolo Angle	Versione Motore Motor Version	Opzioni Options
 <p><b>NDCM</b></p>	120/026	180/026	U F...	Vedere tabella See tables	SZDX SZSX DZ	BRDX BRSX	0° 90° 180° 270°	120 — 240	VS
	120/026 (D11)	180/026 (D11)							
	120/026 (D14)	180/026 (D14)							
	120/030	180/030							
	120/040	180/040							

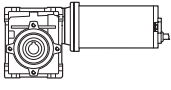
MOTORIDUTTORE / GEARMOTOR											
ECM	070/026				U	10	SZDX	BRSX	90	240	VS
Tipo Type	Grandezza Size				Versione Riduttore Gearbox Version	Rapporto Ratio	Albero di uscita Output shaft	Braccio di reazione Torque arm	Angolo Angle	Versione Motore Motor Version	Opzioni Options
 <p><b>ECM</b></p>	035/026	070/026	100/026	180/026	250/030	U F...	Vedere tabella See tables	SZDX SZSX DZ	BRDX BRSX	0° 90° 180° 270°	120 240 24E
	035/026 (D11)	070/026 (D11)	100/026 (D11)	180/026 (D11)	250/040						
	035/026 (D14)	070/026 (D14)	100/026 (D14)	180/026 (D14)	350/030						
	035/030	070/030	100/030	180/030	350/040						
	050/026		100/040	180/040	600/040						
	050/026 (D11)										
	050/026 (D14)										
050/030											

Versione Riduttore  
Gearbox Version

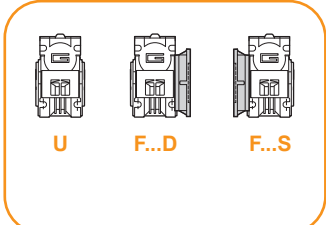

U    F...D    F...S

Albero di uscita  
Output shaft

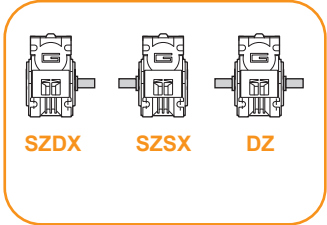

SZDX    SZSX    DZ

Braccio di reazione  
Torque arm

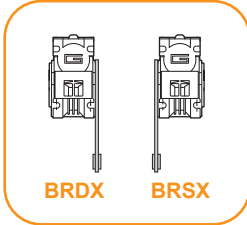

BRDX    BRSX

Angolo  
Angle

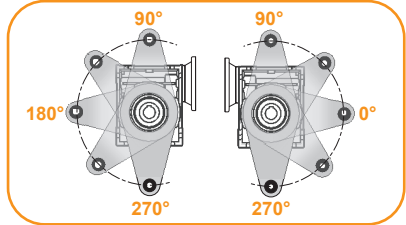

90°    90°  
180°    180°  
270°    270°

\* NOTA: il braccio di reazione viene fornito smontato.  
NOTE: the torque arm will be supplied not assembled.



### Simbologia

### Symbols

$n_1$ [min <sup>-1</sup> ]	Velocità in ingresso / <i>Input speed</i>	$R_d$ %	Rendimento dinamico / <i>Dynamic efficiency</i>
$n_2$ [min <sup>-1</sup> ]	Velocità in uscita / <i>Output speed</i>	$A_2$ [N]	Carico assiale ammissibile in uscita / <i>Permitted output axial load</i>
$i$	Rapporto di riduzione / <i>Ratio</i>	$R_s$ %	Rendimento statico / <i>Static efficiency</i>
$P_1$ [kW]	Potenza in entrata / <i>Input power</i>	$R_2$ [N]	Carico radiale ammissibile in uscita / <i>Permitted output radial load</i>
$M_2$ [Nm]	Coppia in uscita in funzione di $P_1$ / <i>Output torque referred to <math>P_1</math></i>	$Z$	Numero di principi della vite / <i>Worm starts</i>
$sf$	Fattore di servizio / <i>Service factor</i>	$\beta$	Angolo d'elica / <i>Helix angle</i>

### Lubrificazione

### Lubrication

I riduttori a vite senza fine della serie CM sono lubrificati a vita con olio sintetico di viscosità 320 e possono essere installati in qualunque posizione di montaggio.

*Permanent synthetic oil long-life lubrication allow to use CM wormgearbox range in all mounting position.*

### Carichi radiali

### Radial loads

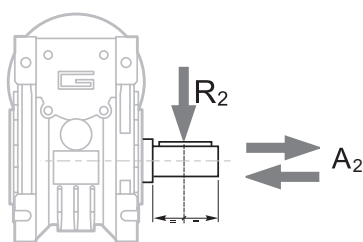

$$A_2 = R_2 \times 0.2$$

$n_2$ [min <sup>-1</sup> ]	$R_2$ [N]		
	CM026	CM030	CM040
187	400	674	1264
140	490	743	1392
93	580	851	1596
70	610	936	1754
56	610	1008	1890
47	610	1069	2004
35	610	1179	2210
28	610	1270	2381
23	610	1356	2542
18	610	1471	2759
14	610	1600	3000

Quando il carico radiale risultante non è applicato sulla mezzera dell'albero occorre calcolare quello effettivo con la seguente formula:

*When the resulting radial load is not applied on the centre line of the shaft it is necessary to calculate the effective load with the following formula:*

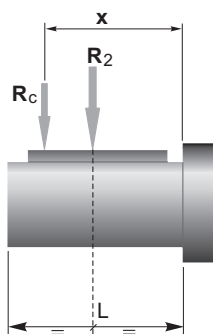

$$R_c = \frac{R_2 \cdot a}{(b + x)} \leq R_{2MAX}$$

$$R \leq R_c$$

*a, b = valori riportati nella tabella*  
*a, b = values given in the table*

	CM		
	026	030	040
<b>a</b>	56	65	84
<b>b</b>	43	50	64
<b><math>R_{2MAX}</math></b>	610	1600	3000

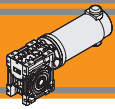

**Dati di dentatura**

**Toothing data**

	Dati della coppia vite-corona Worm wheel data	Rapporto / Ratio											
		5	7.5	10	15	20	25	30	40	50	60	80	100
CM026	Z	6	4	3	2	2		1	1	1	1		
	$\beta$	34° 35'	24° 41'	19° 1'	12° 57'	10° 30'		6° 33'	5° 17'	4° 26'	3° 49'		
CM030	Z	6	4	3	2	2	2	1	1	1	1	1	1
	$\beta$	27° 4'	24° 28'	18° 50'	12° 49'	10° 23'	8° 43'	6° 29'	5° 14'	4° 23'	3° 46'	2° 57'	2° 25'
CM040	Z	6	4	3	2	2	2	1	1	1	1	1	1
	$\beta$	34° 19'	24° 28'	18° 50'	12° 49'	10° 23'	8° 43'	6° 29'	5° 14'	4° 23'	3° 46'	2° 57'	2° 25'

**Rendimento**

**Efficiency**

	$n_1$ [min <sup>-1</sup> ]	Rendimento Efficiency	Rapporto / Ratio												
			5	7.5	10	15	20	25	30	40	50	60	80	100	
CM026	2800	Rd	89	87	85	83	80		73	68	64	60			
			1400	87	84	83	78	74		66	61	57	53		
			900	84	83	80	75	71		61	57	52	48		
		Rs	72	71	68	61	56		46	41	36	34			
CM030	2800	Rd	89	88	86	84	81	78	74	70	65	62	57	52	
			1400	86	85	84	79	75	72	67	62	58	55	48	43
			900	84	83	81	75	71	68	62	58	53	49	43	39
		Rs	72	67	63	55	50	43	39	35	31	27	23	21	
CM040	2800	Rd	90	89	87	84	83	80	77	73	69	66	60	56	
			1400	88	86	84	81	78	74	70	65	60	58	52	46
			900	86	84	82	77	74	70	66	60	57	53	46	41
		Rs	74	71	67	60	55	51	45	40	36	32	28	24	



**Rendimento teorico del riduttore dopo il rodaggio**  
*Theoretical efficiency of the gearbox after the first running period*

**Dati tecnici per servizio S2**
**NDCM**
**Technical data for S2 duty**

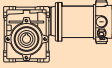
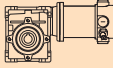
$P_1$ [W]	$n_2$ [min <sup>-1</sup> ]	$M_2$ [Nm]	sf	i		Versione motore Motor version	$P_1$ [W]	$n_2$ [min <sup>-1</sup> ]	$M_2$ [Nm]	sf	i		Versione motore Motor version
<b>160</b>							<b>250</b>						
(3000 min <sup>-1</sup> )	<b>600</b>	2	4.4	5	<b>120/026</b>	<b>120/240</b>	(3000 min <sup>-1</sup> )	<b>600</b>	4	2.8	5	<b>180/026</b>	<b>120/240</b>
	<b>400</b>	3	3.3	7.5	<b>120/026</b>			<b>400</b>	5	2.1	7.5	<b>180/026</b>	
	<b>300</b>	4	2.5	10	<b>120/026</b>			<b>300</b>	7	1.6	10	<b>180/026</b>	
	<b>200</b>	6	1.7	15	<b>120/026</b>			<b>200</b>	10	1.1	15	<b>180/026</b>	
	<b>150</b>	8	1.3	20	<b>120/026</b>			<b>150</b>	13	0.9	20	<b>180/026</b>	
	<b>100</b>	11	1.1	30	<b>120/026</b>			<b>100</b>	17	0.7	30	<b>180/026</b>	
	<b>75</b>	14	0.8	40	<b>120/026</b>			<b>75</b>	16	0.7	40	<b>180/026</b>	
	<b>60</b>	14	0.7	50	<b>120/026</b>			<b>60</b>	14	0.7	50	<b>180/026</b>	
	<b>50</b>	13	0.7	60	<b>120/026</b>			<b>50</b>	13	0.7	60	<b>180/026</b>	
	<b>600</b>	2	5.7	5	<b>120/030</b>	<b>120/240</b>		<b>600</b>	4	3.7	5	<b>180/030</b>	<b>120/240</b>
	<b>400</b>	3	4.5	7.5	<b>120/030</b>			<b>400</b>	5	2.9	7.5	<b>180/030</b>	
	<b>300</b>	4	3.7	10	<b>120/030</b>			<b>300</b>	7	2.3	10	<b>180/030</b>	
	<b>200</b>	6	2.5	15	<b>120/030</b>			<b>200</b>	10	1.6	15	<b>180/030</b>	
	<b>150</b>	8	1.7	20	<b>120/030</b>			<b>150</b>	13	1.1	20	<b>180/030</b>	
	<b>120</b>	10	1.5	25	<b>120/030</b>			<b>120</b>	16	1.0	25	<b>180/030</b>	
	<b>100</b>	11	1.6	30	<b>120/030</b>			<b>100</b>	18	1.0	30	<b>180/030</b>	
	<b>75</b>	14	1.1	40	<b>120/030</b>			<b>75</b>	22	0.7	40	<b>180/030</b>	
	<b>60</b>	17	0.9	50	<b>120/030</b>			<b>60</b>	21	0.7	50	<b>180/030</b>	
	<b>50</b>	20	0.7	60	<b>120/030</b>			<b>50</b>	20	0.7	60	<b>180/030</b>	
	<b>38</b>	17	0.7	80	<b>120/030</b>			<b>38</b>	17	0.7	80	<b>180/030</b>	
	<b>30</b>	16	0.7	100	<b>120/030</b>			<b>30</b>	16	0.7	100	<b>180/030</b>	
	<b>150</b>	8	3.7	20	<b>120/040</b>	<b>120/240</b>		<b>600</b>	4	8.1	5	<b>180/040</b>	<b>120/240</b>
	<b>120</b>	10	2.7	25	<b>120/040</b>			<b>400</b>	5	5.8	7.5	<b>180/040</b>	
	<b>100</b>	12	3.2	30	<b>120/040</b>			<b>300</b>	7	4.8	10	<b>180/040</b>	
	<b>75</b>	15	2.3	40	<b>120/040</b>			<b>200</b>	10	3.5	15	<b>180/040</b>	
	<b>60</b>	18	1.8	50	<b>120/040</b>			<b>150</b>	13	2.3	20	<b>180/040</b>	
	<b>50</b>	20	1.4	60	<b>120/040</b>			<b>120</b>	16	1.8	25	<b>180/040</b>	
	<b>38</b>	24	1.1	80	<b>120/040</b>			<b>100</b>	18	2.1	30	<b>180/040</b>	
	<b>30</b>	29	0.8	100	<b>120/040</b>			<b>75</b>	23	1.5	40	<b>180/040</b>	
								<b>60</b>	27	1.2	50	<b>180/040</b>	
								<b>50</b>	32	0.9	60	<b>180/040</b>	
								<b>38</b>	38	0.7	80	<b>180/040</b>	
								<b>30</b>	34	0.7	100	<b>180/040</b>	

N.B.

 Verificare sempre che la coppia  $M_2$  utilizzata non ecceda il valore indicato nelle caselle in grigio

N.B.

 Please check that the output torque  $M_2$  does not exceed the value in the grey areas

**NOTA:** per servizio continuo o altamente intermittente, contattare il servizio tecnico

**NOTE:** for continuous or highly intermittent duty, please contact our technical service

**Dati tecnici elettrici**
**Electrical technical data**

 ND 120 → 

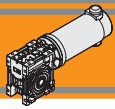

 ND 180 → 







### Dati tecnici per servizio S2



### ECM

### Technical data for S2 duty

P <sub>1</sub> [W]	n <sub>2</sub> [min <sup>-1</sup> ]	M <sub>2</sub> [Nm]	sf	i		Versione motore Motor version
<b>55</b>						
(3000 min <sup>-1</sup> )	<b>600</b>	0.8	12.8	5		ECM035/026 120/240
	<b>400</b>	1.1	9.6	7.5		
	<b>300</b>	1.5	7.4	10		
	<b>200</b>	2.2	5.0	15		
	<b>150</b>	2.8	3.9	20		
	<b>100</b>	3.8	3.1	30		
	<b>75</b>	4.8	2.3	40		
	<b>60</b>	5.6	1.8	50		
	<b>50</b>	6.3	1.4	60		
	<b>600</b>	0.8	16.7	5		
	<b>400</b>	1.2	13.0	7.5		ECM035/030 120/240
	<b>300</b>	1.5	10.6	10		
	<b>200</b>	2.2	7.3	15		
	<b>150</b>	2.8	4.9	20		
	<b>120</b>	3.4	4.4	25		
	<b>100</b>	3.9	4.6	30		
	<b>75</b>	4.9	3.3	40		
	<b>60</b>	5.7	2.6	50		
	<b>50</b>	6.5	2.1	60		
	<b>38</b>	8.0	1.5	80		
	<b>30</b>	9.1	1.2	100		

P <sub>1</sub> [W]	n <sub>2</sub> [min <sup>-1</sup> ]	M <sub>2</sub> [Nm]	sf	i		Versione motore Motor version
<b>100</b>						
(3000 min <sup>-1</sup> )	<b>600</b>	1.4	7.1	5		ECM070/026 12E/24E
	<b>400</b>	2.1	5.3	7.5		
	<b>300</b>	2.7	4.1	10		
	<b>200</b>	4.0	2.8	15		
	<b>150</b>	5.1	2.2	20		
	<b>100</b>	7.0	1.7	30		
	<b>75</b>	8.7	1.3	40		
	<b>60</b>	10	1.0	50		
	<b>50</b>	11	0.8	60		
	<b>600</b>	1.4	9.2	5		
	<b>400</b>	2.1	7.1	7.5		ECM070/030 12E/24E
	<b>300</b>	2.7	5.8	10		
	<b>200</b>	4.0	4.0	15		
	<b>150</b>	5.2	2.7	20		
	<b>120</b>	6.2	2.4	25		
	<b>100</b>	7.1	2.5	30		
	<b>75</b>	8.9	1.8	40		
	<b>60</b>	10	1.4	50		
	<b>50</b>	12	1.2	60		
	<b>38</b>	15	0.8	80		
	<b>30</b>	17	0.7	100		

<b>70</b>						
(3000 min <sup>-1</sup> )	<b>600</b>	1.0	10.1	5		ECM050/026 120/240
	<b>400</b>	1.5	7.6	7.5		
	<b>300</b>	1.9	5.8	10		
	<b>200</b>	2.8	4.0	15		
	<b>150</b>	3.6	3.1	20		
	<b>100</b>	4.9	2.5	30		
	<b>75</b>	6.1	1.8	40		
	<b>60</b>	7.1	1.4	50		
	<b>50</b>	8.0	1.1	60		
	<b>600</b>	1.0	13.1	5		
	<b>400</b>	1.5	10.2	7.5		ECM050/030 120/240
	<b>300</b>	1.9	8.3	10		
	<b>200</b>	2.8	5.7	15		
	<b>150</b>	3.6	3.9	20		
	<b>120</b>	4.3	3.5	25		
	<b>100</b>	4.9	3.6	30		
	<b>75</b>	6.2	2.6	40		
	<b>60</b>	7.2	2.1	50		
	<b>50</b>	8.3	1.7	60		
	<b>38</b>	10.2	1.2	80		
	<b>30</b>	11.6	0.9	100		

<b>140</b>						
(3000 min <sup>-1</sup> )	<b>600</b>	2.0	5.0	5		ECM100/026 120/240/24E
	<b>400</b>	2.9	3.8	7.5		
	<b>300</b>	3.8	2.9	10		
	<b>200</b>	5.5	2.0	15		
	<b>150</b>	7.1	1.5	20		
	<b>100</b>	10	1.2	30		
	<b>75</b>	12	0.9	40		
	<b>60</b>	14	0.7	50		
	<b>50</b>	13	0.7	60		
	<b>200</b>	5.6	2.8	15		
	<b>150</b>	7.2	1.9	20		ECM100/030 120/240/24E
	<b>120</b>	8.7	1.7	25		
	<b>100</b>	10	1.8	30		
	<b>75</b>	12	1.3	40		
	<b>60</b>	14	1.0	50		
	<b>50</b>	17	0.8	60		
	<b>38</b>	17	0.7	80		
	<b>30</b>	16	0.7	100		
	<b>100</b>	10	3.7	30		
	<b>75</b>	13	2.6	40		
	<b>60</b>	15	2.1	50		
	<b>50</b>	18	1.6	60		
	<b>38</b>	21	1.3	80		
	<b>30</b>	25	1.0	100		
	<b>100</b>	10	3.7	30		ECM100/040 120/240/24E
	<b>75</b>	13	2.6	40		
	<b>60</b>	15	2.1	50		
	<b>50</b>	18	1.6	60		
	<b>38</b>	21	1.3	80		
	<b>30</b>	25	1.0	100		

NOTA  
Verificare sempre che la coppia M2 utilizzata non ecceda il valore indicato nelle caselle in grigio

NOTE  
Please check that the output torque M2 does not exceed the value in the grey areas

**NOTA:** per servizio continuo o altamente intermittente, contattare il servizio tecnico

**NOTE:** for continuous or highly intermittent duty, please contact our technical service

### Dati tecnici elettrici

### Electrical technical data







Dati tecnici per servizio S2

ECM

Technical data for S2 duty

P <sub>1</sub> [W]	n <sub>2</sub> [min <sup>-1</sup> ]	M <sub>2</sub> [Nm]	sf	i		Versione motore Motor version
-----------------------	--	------------------------	----	---	--	----------------------------------

P <sub>1</sub> [W]	n <sub>2</sub> [min <sup>-1</sup> ]	M <sub>2</sub> [Nm]	sf	i		Versione motore Motor version
-----------------------	--	------------------------	----	---	--	----------------------------------

250

(3000 min <sup>-1</sup> )	<b>600</b>	3.5	2.8	5	ECM180/026	120/240		
	<b>400</b>	5.2	2.1	7.5				
	<b>300</b>	6.8	1.6	10				
	<b>200</b>	10	1.1	15				
	<b>150</b>	13	0.9	20				
	<b>100</b>	17	0.7	30				
	<b>75</b>	16	0.7	40				
	<b>60</b>	14	0.7	50				
	<b>50</b>	13	0.7	60				
	<b>600</b>	3.5	3.7	5			ECM180/030	120/240/24E
	<b>400</b>	5.3	2.9	7.5				
	<b>300</b>	6.8	2.3	10				
	<b>200</b>	10	1.6	15				
	<b>150</b>	13	1.1	20				
	<b>120</b>	16	1.0	25				
	<b>100</b>	18	1.0	30				
	<b>75</b>	22	0.7	40				
	<b>60</b>	21	0.7	50				
	<b>50</b>	20	0.7	60				
	<b>38</b>	17	0.7	80				
	<b>30</b>	16	0.7	100				
	<b>200</b>	10	3.5	15	ECM180/040	120/240/24E		
	<b>150</b>	13	2.3	20				
	<b>120</b>	16	1.8	25				
	<b>100</b>	18	2.1	30				
	<b>75</b>	23	1.5	40				
	<b>60</b>	27	1.2	50				
	<b>50</b>	32	0.9	60				
	<b>38</b>	38	0.7	80				
	<b>30</b>	34	0.7	100				

500

(3000 min <sup>-1</sup> )	<b>600</b>	7.1	1.8	5	ECM350/030	120/240		
	<b>400</b>	11	1.4	7.5				
	<b>300</b>	14	1.2	10				
	<b>200</b>	20	0.8	15				
	<b>150</b>	20	0.7	20				
	<b>120</b>	21	0.7	25				
	<b>100</b>	26	0.7	30				
	<b>75</b>	23	0.7	40				
	<b>60</b>	21	0.7	50				
	<b>600</b>	7.2	4.0	5			ECM350/040	120/240
	<b>400</b>	11	2.9	7.5				
	<b>300</b>	14	2.4	10				
	<b>200</b>	20	1.7	15				
	<b>150</b>	26	1.2	20				
	<b>120</b>	32	0.9	25				
	<b>100</b>	37	1.0	30				
	<b>75</b>	46	0.7	40				
	<b>60</b>	46	0.7	50				
	<b>50</b>	41	0.7	60				
	<b>38</b>	39	0.7	80				
	<b>30</b>	34	0.7	100				

800

(3000 min <sup>-1</sup> )	<b>600</b>	11	2.5	5	ECM600/040	120/240
	<b>400</b>	17	1.8	7.5		
	<b>300</b>	22	1.5	10		
	<b>200</b>	32	1.1	15		
	<b>150</b>	42	0.7	20		
	<b>120</b>	40	0.7	25		
	<b>100</b>	54	0.7	30		
	<b>75</b>	49	0.7	40		

350

(3000 min <sup>-1</sup> )	<b>600</b>	5.0	2.6	5	ECM250/030	120/240		
	<b>400</b>	7.4	2.0	7.5				
	<b>300</b>	10	1.7	10				
	<b>200</b>	14	1.1	15				
	<b>150</b>	18	0.8	20				
	<b>120</b>	22	0.7	25				
	<b>100</b>	25	0.7	30				
	<b>75</b>	22	0.7	40				
	<b>60</b>	21	0.7	50				
	<b>200</b>	14	2.5	15			ECM250/040	120/240
	<b>150</b>	18	1.7	20				
	<b>120</b>	22	1.3	25				
	<b>100</b>	26	1.5	30				
	<b>75</b>	33	1.0	40				
	<b>60</b>	38	0.8	50				
	<b>50</b>	44	0.7	60				
	<b>38</b>	38	0.7	80				
	<b>30</b>	35	0.7	100				

N.B.  
Verificare sempre che la coppia M2 utilizzata non ecceda il valore indicato nelle caselle in grigio  
N.B.  
Please check that the output torque M2 does not exceed the value in the grey areas

NOTA: per servizio continuo o altamente intermittente, contattare il servizio tecnico

NOTE: for continuous or highly intermittent duty, please contact our technical service

Dati tecnici elettrici

Electrical technical data



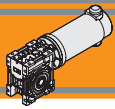

Motori applicabili

Motor adapters

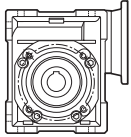
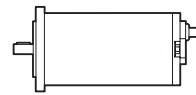
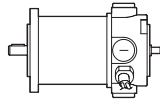

		ND		EC								
		120.120 120.240	180.120 180.240	035.12E 035.24E	050.12E 050.24E	070.12E 070.24E	100.120 100.240 100.24E	180.120 180.240	180.24E	250.120 250.240	350.120 350.240	600.120 600.240
CM	026	5-60	5-60	5-60	5-60	5-60	5-60	5-60				
	030	5-100	5-100	5-100	5-100	5-100	5-100	5-100	5-50	5-50	5-50	
	040	5-100	5-100			5-100	5-100	5-100	5-100	5-100	5-100	5-40

5-100 Rapporti di riduzione i  
Ratio i

Dimensioni

Dimensions

NDCM120/026 U

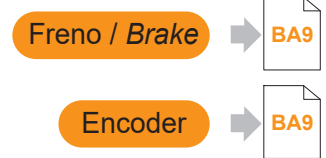
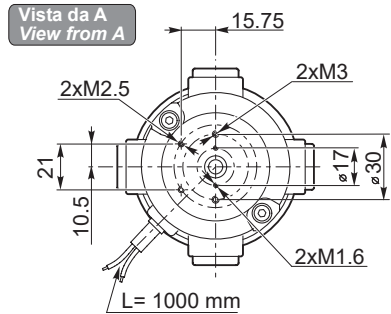
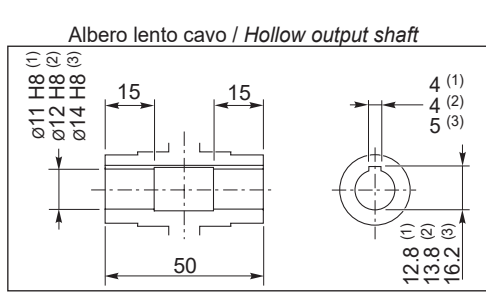
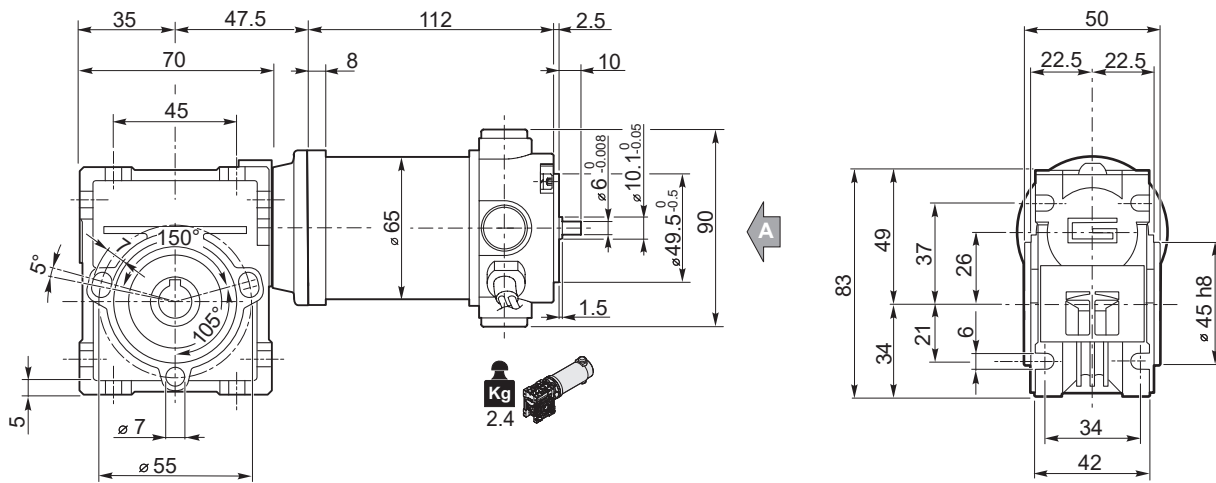

- (1): NDCM 120/026 (D11)
- (2): NDCM 120/026
- (3): NDCM 120/026 (D14)

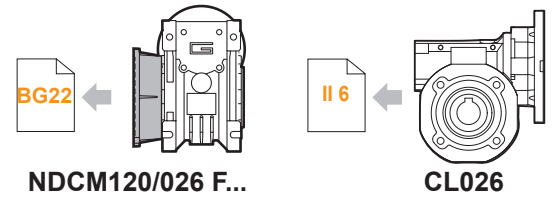

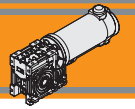

Dimensioni

Dimensions

**NDCM120/030 U**

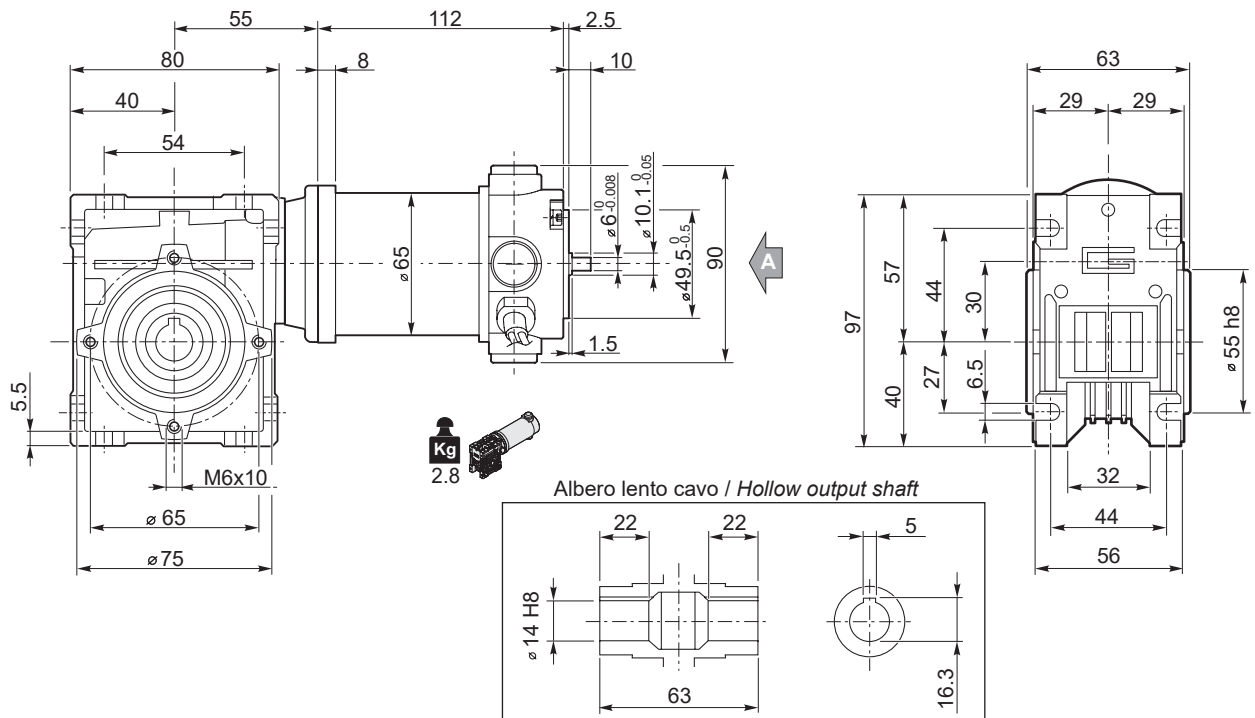

**NDCM120/040 U**

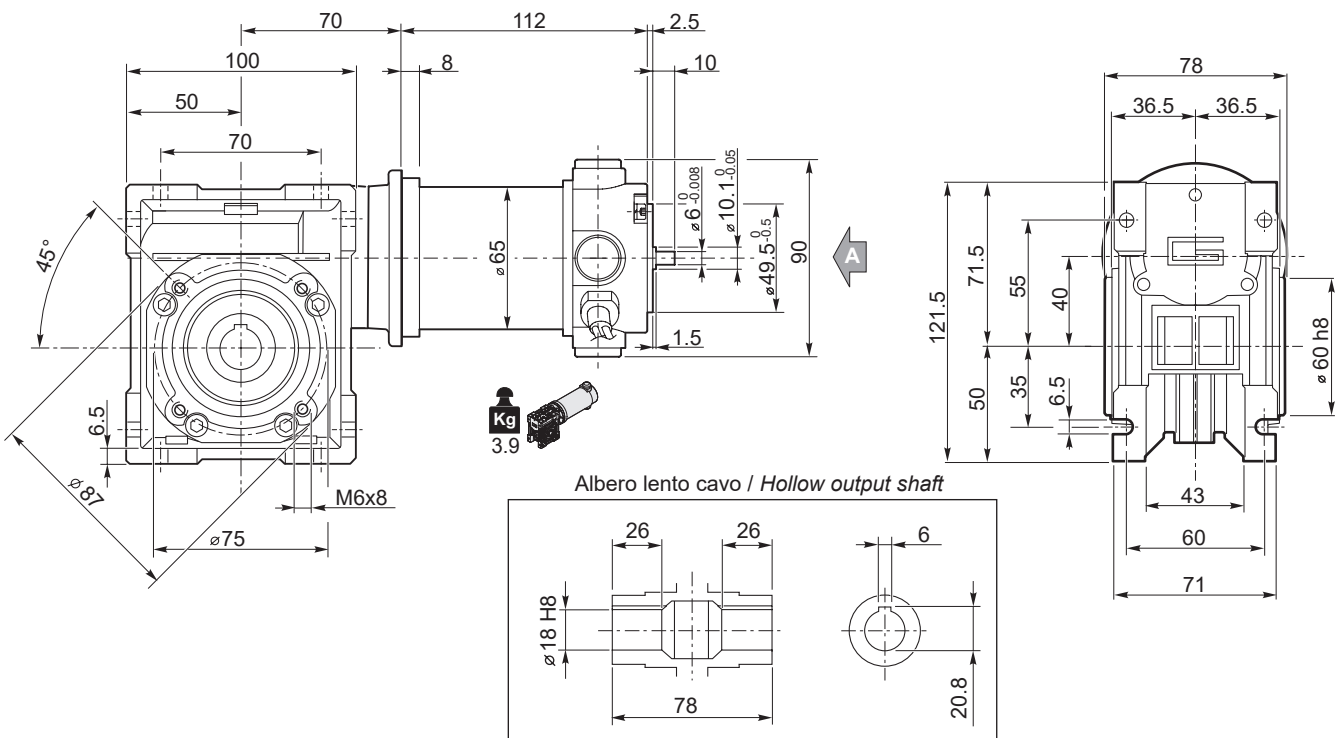

DC

Vista da A  
View from A

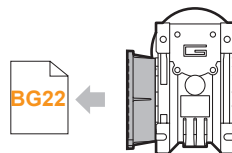
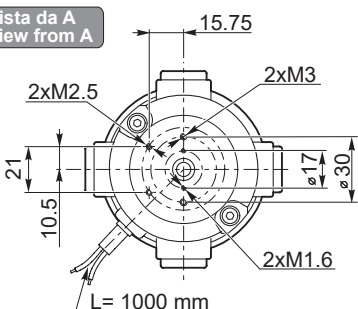

NDCM120/030 F  
NDCM120/040 F...

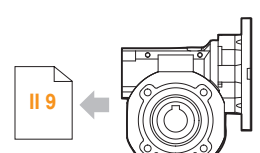

CL030  
CL040

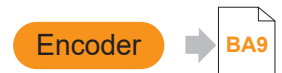

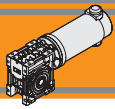

## Dimensioni

## Dimensions

### NDCM180/026 U

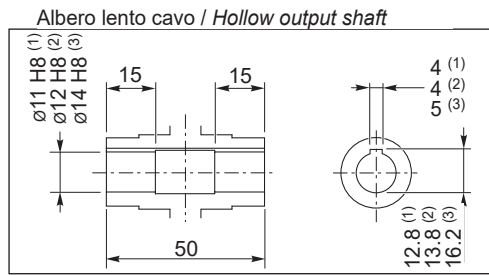
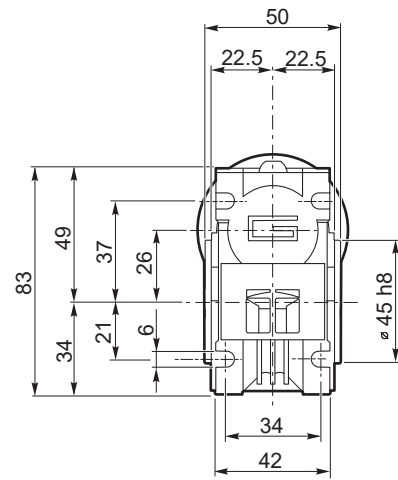
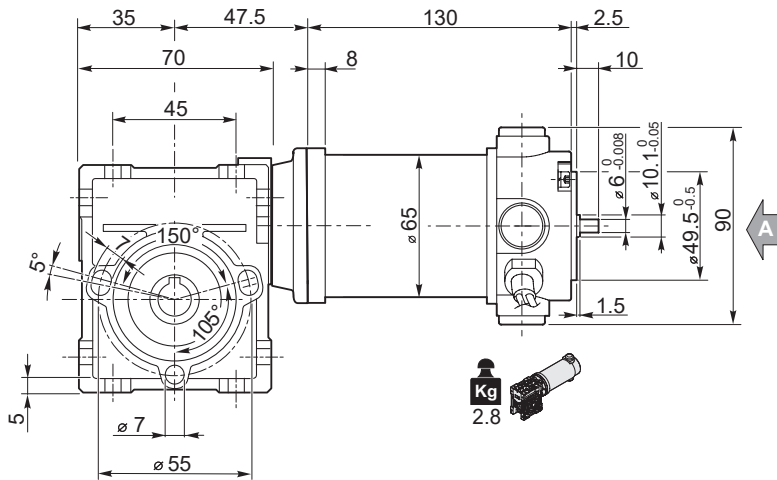

- (1): NDCM 180/026 (D11)
- (2): NDCM 180/026
- (3): NDCM 180/026 (D14)

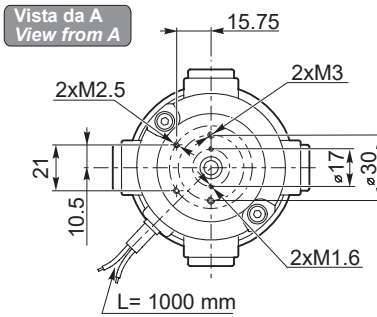

Freno / Brake → BA9

Encoder → BA9

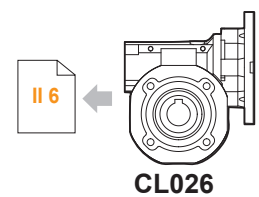
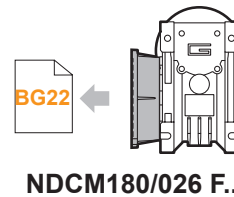



Dimensioni

Dimensions

**NDCM180/030 U**

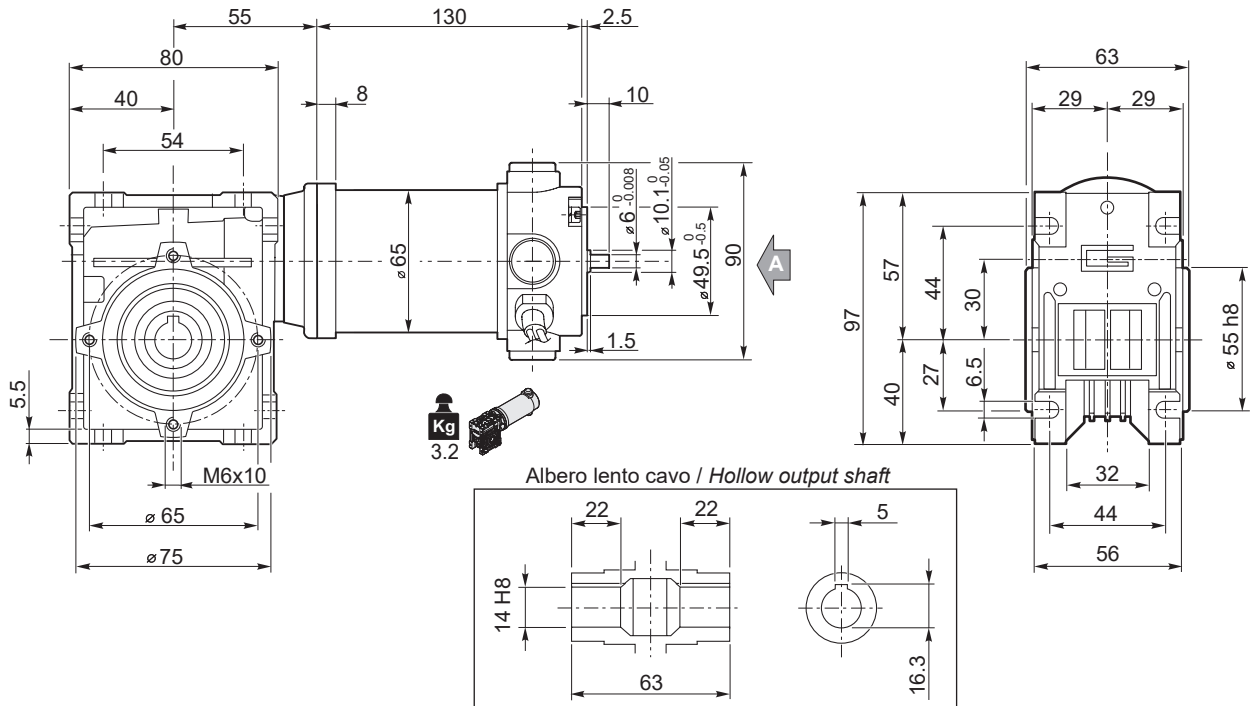

**NDCM180/040 U**

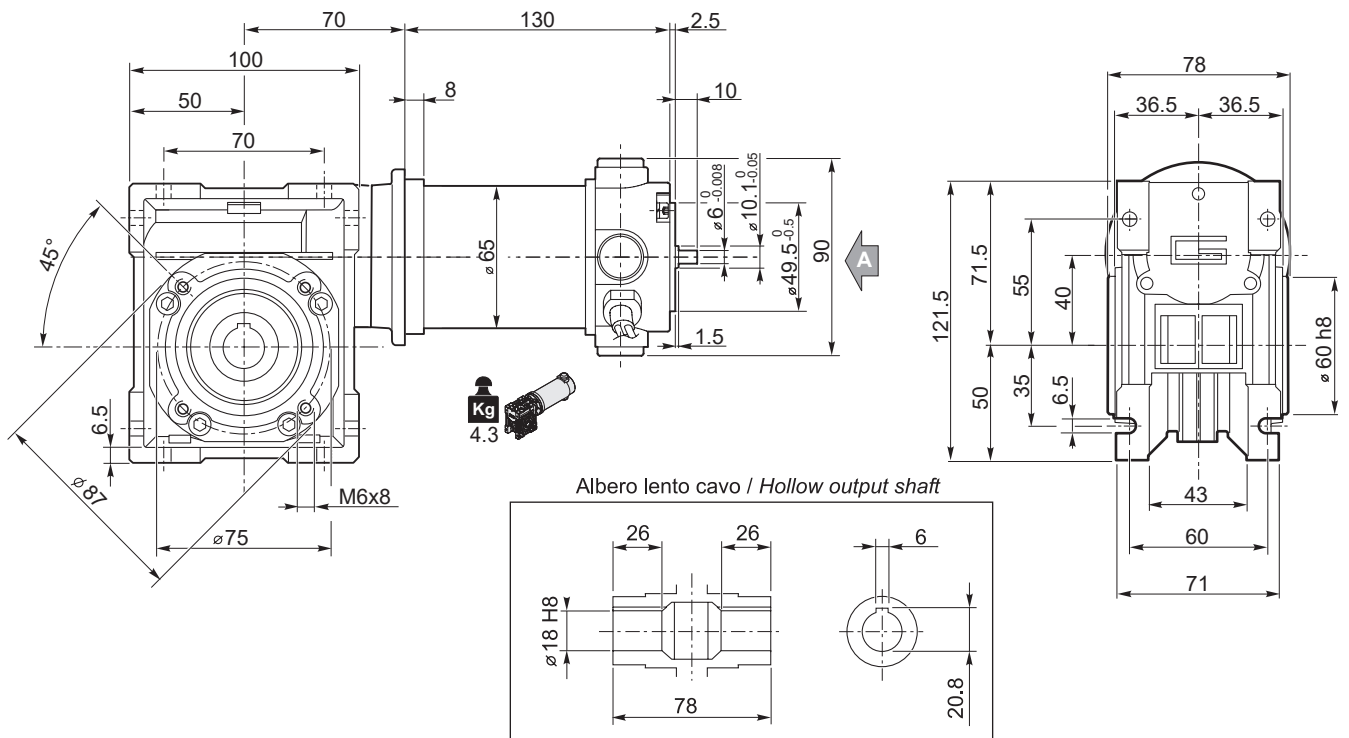

Vista da A  
View from A

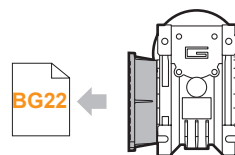
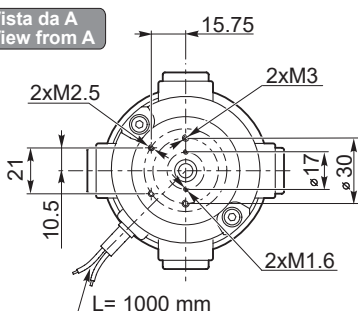

BG22

NDCM180/030 F  
NDCM180/040 F...

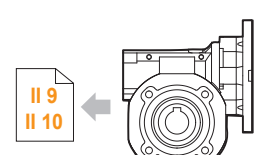

II 9  
II 10

CL030  
CL040

Freno / Brake



Encoder



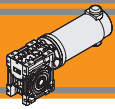

### Dimensioni

### Dimensions

#### ECM035/026 U

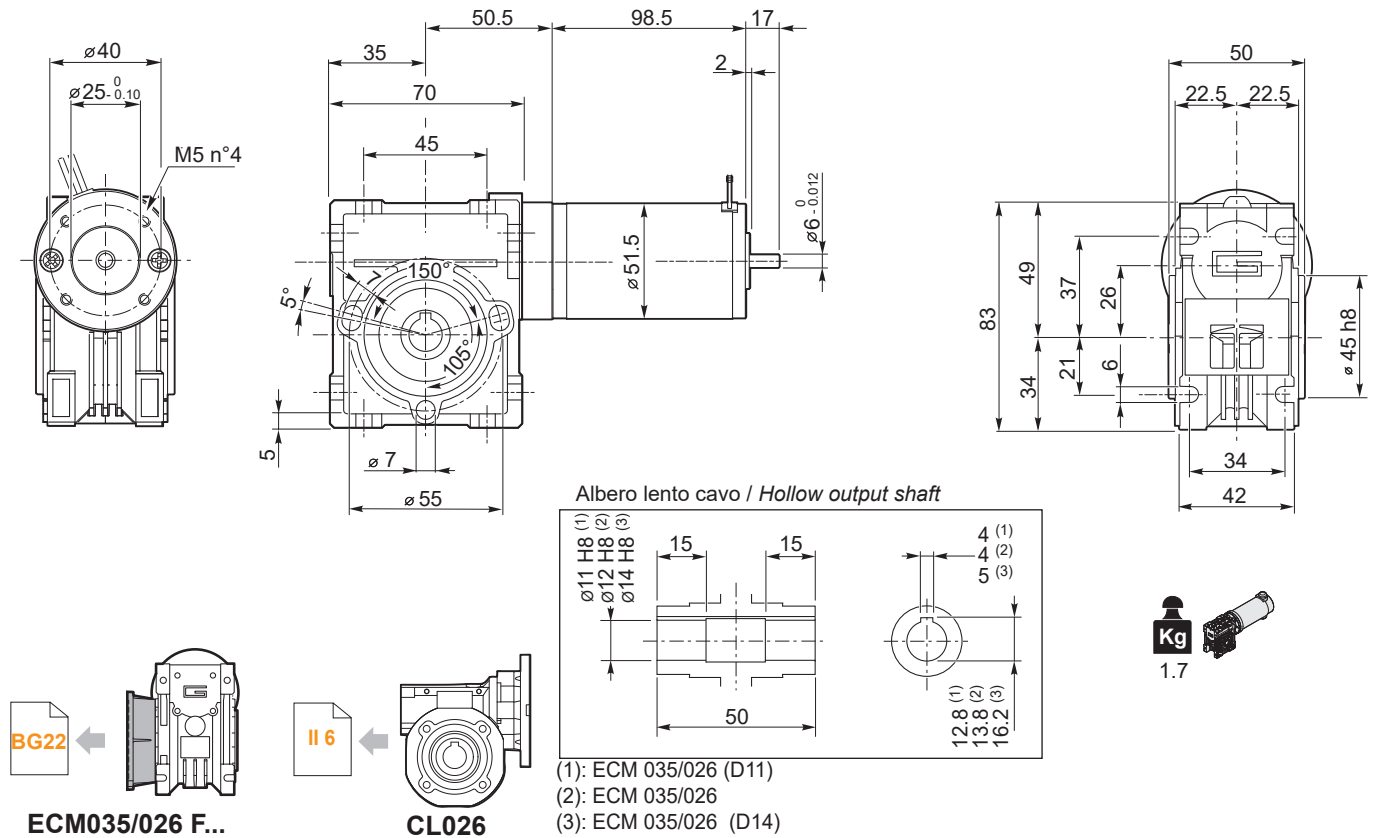

#### ECM035/030 U

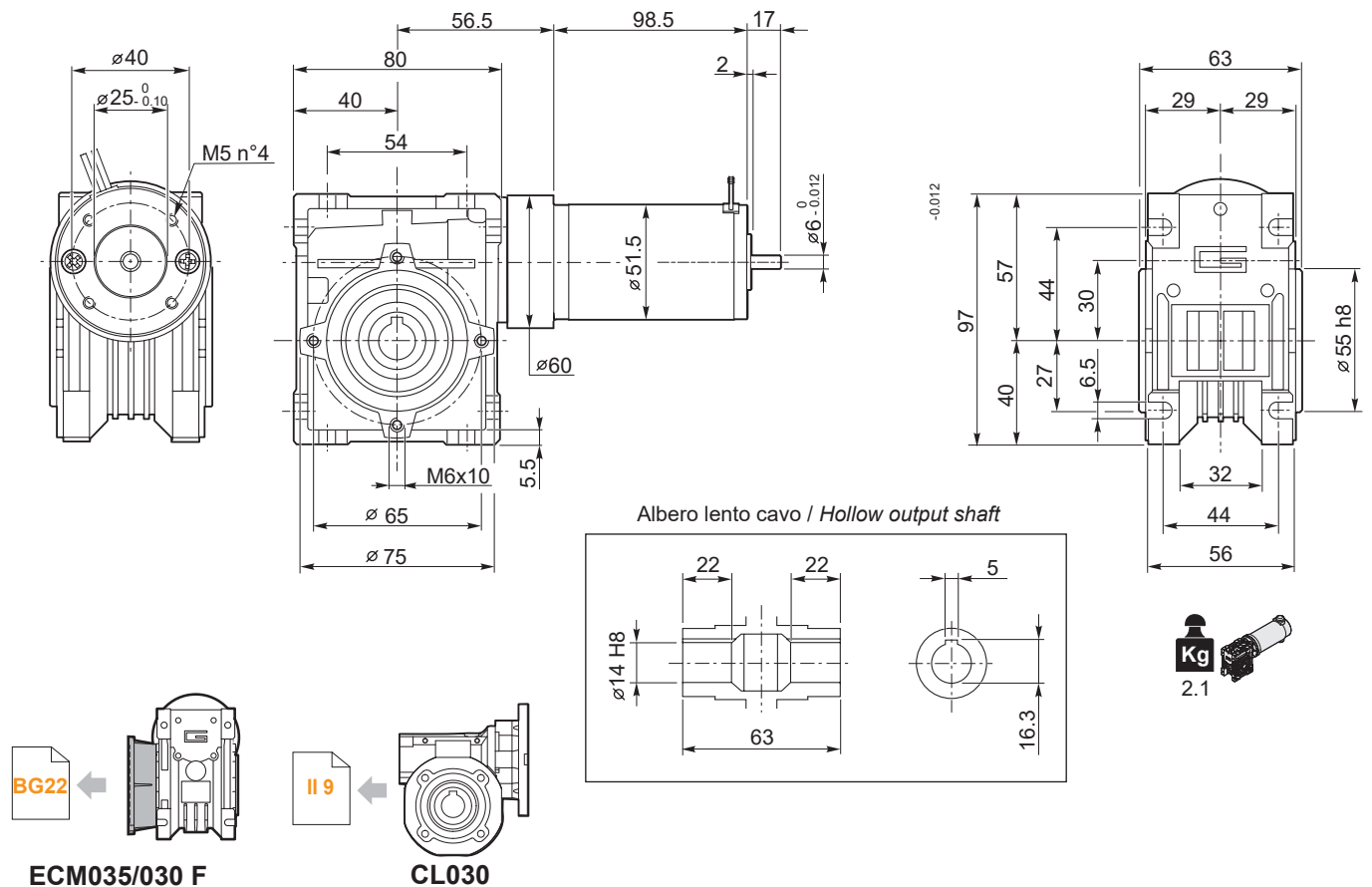



Dimensioni

Dimensions

ECM050/026 U

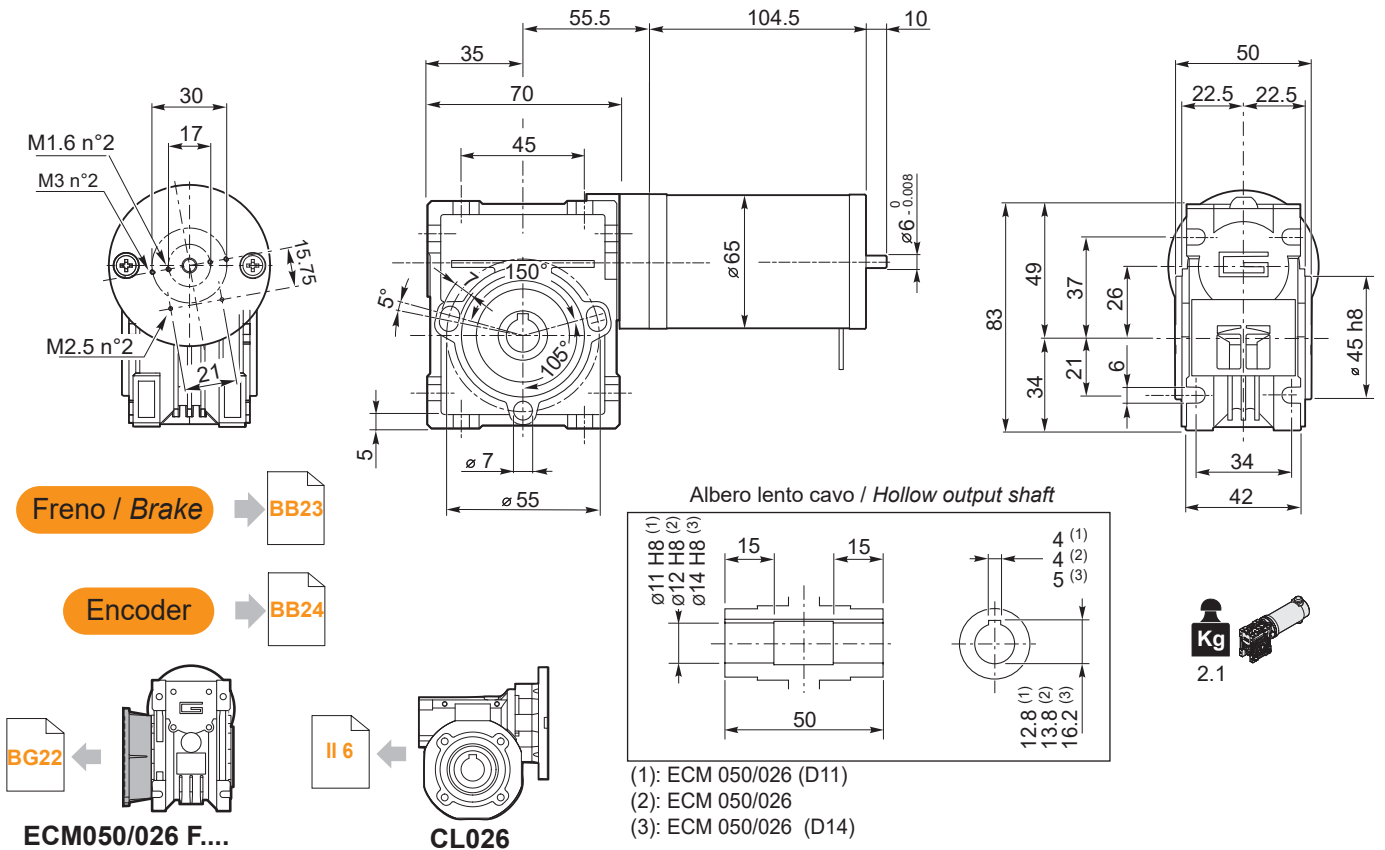

ECM050/030 U

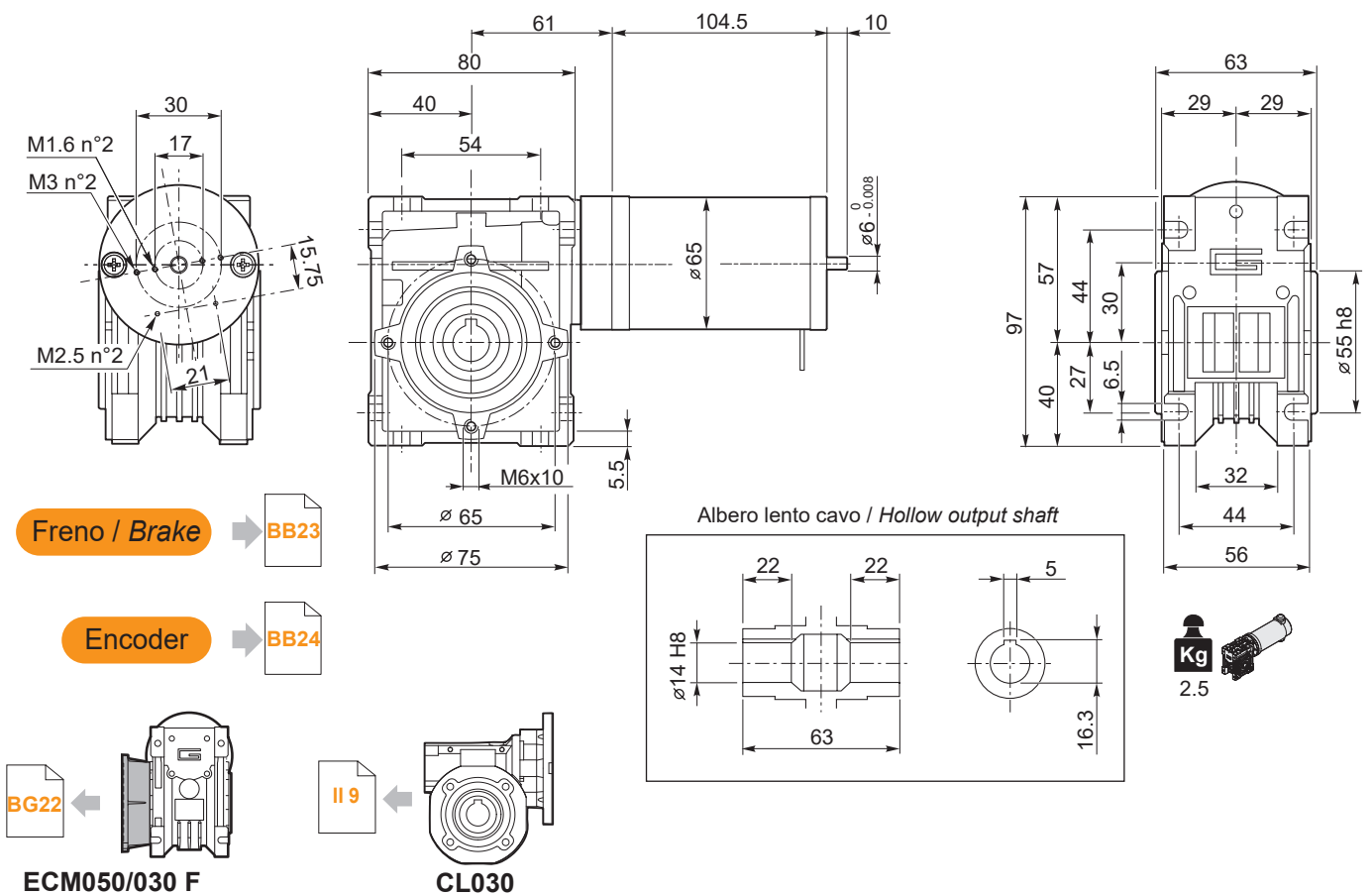

DC

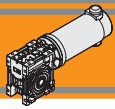

### Dimensioni

### Dimensions

#### ECM070/026 U

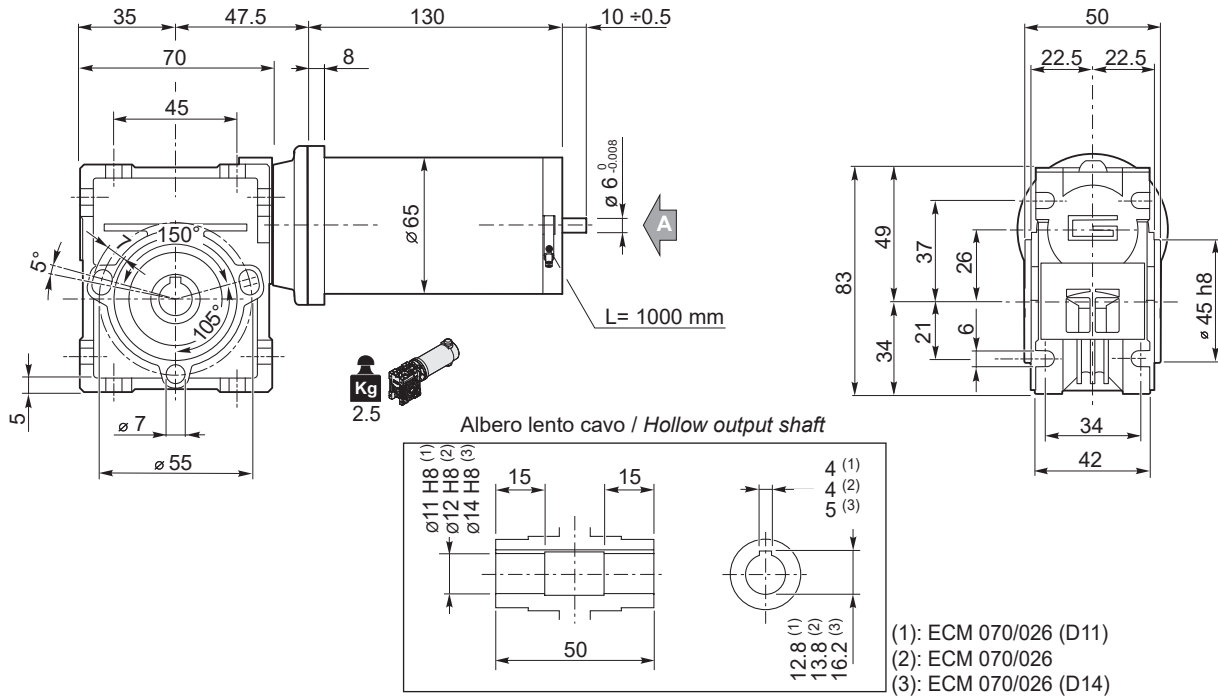

#### ECM070/030 U

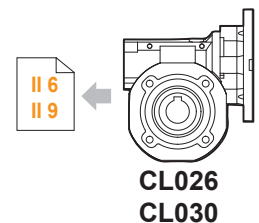
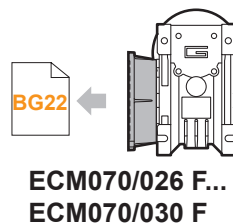
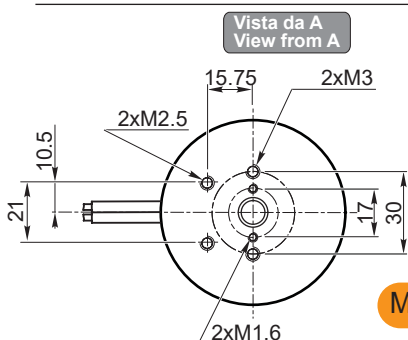
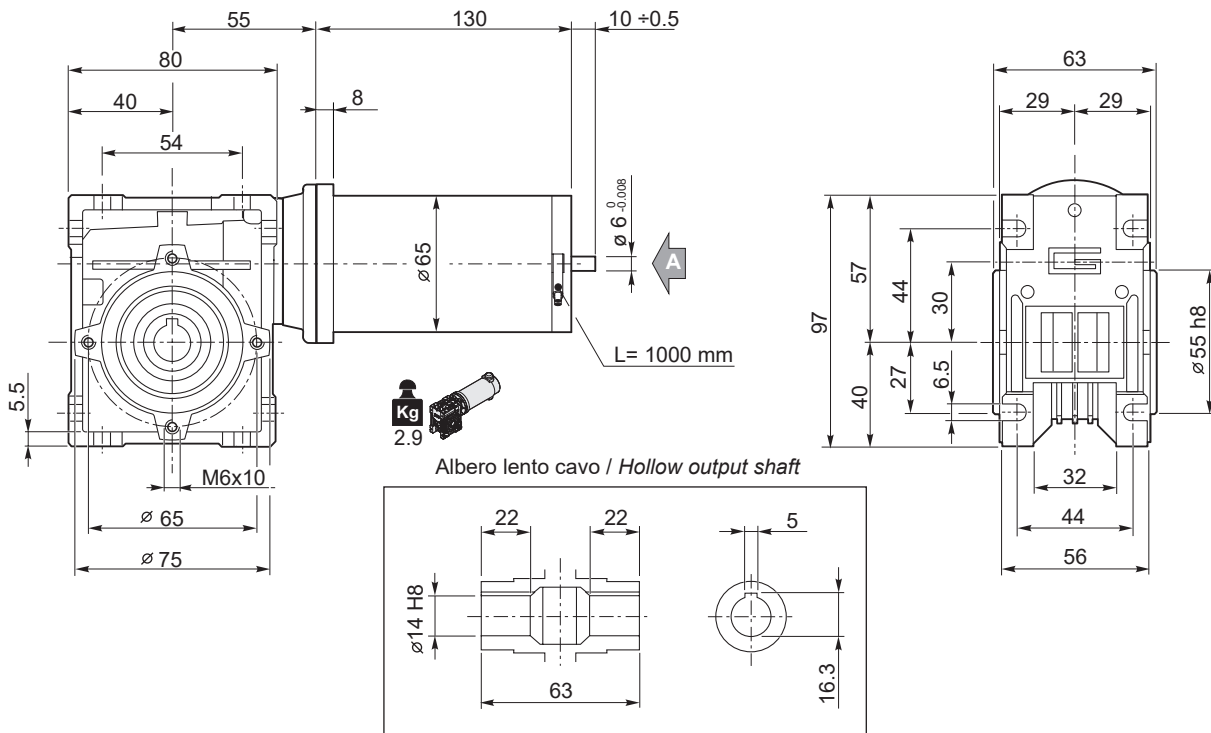

Motori / Motors IP66 → BC2

Freno / Brake → BB23

Encoder → BB24



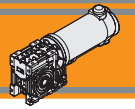

**Dimensioni**

**Dimensions**

**ECM100/026 U**

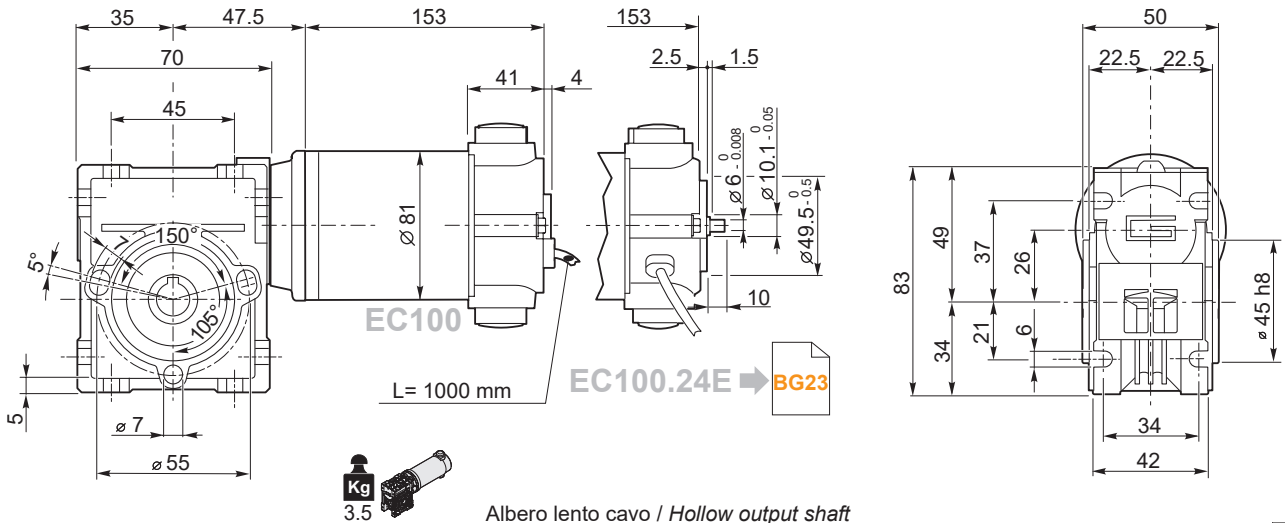

Albero lento cavo / Hollow output shaft

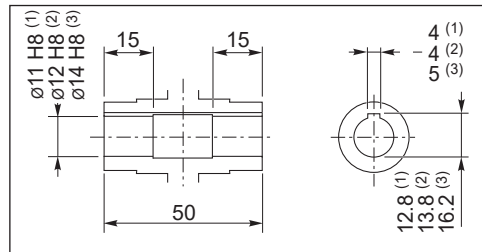
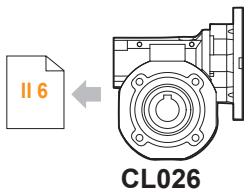
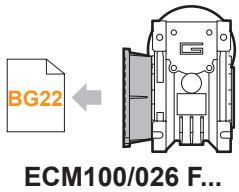

- (1): ECM 100/026 (D11)
- (2): ECM 100/026
- (3): ECM 100/026 (D14)

- Motori / Motors IP66** → **BC4**
- Freno / Brake** → **BB23**
- Encoder** → **BB24**

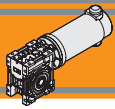

### Dimensioni

### Dimensions

#### ECM100/030 U

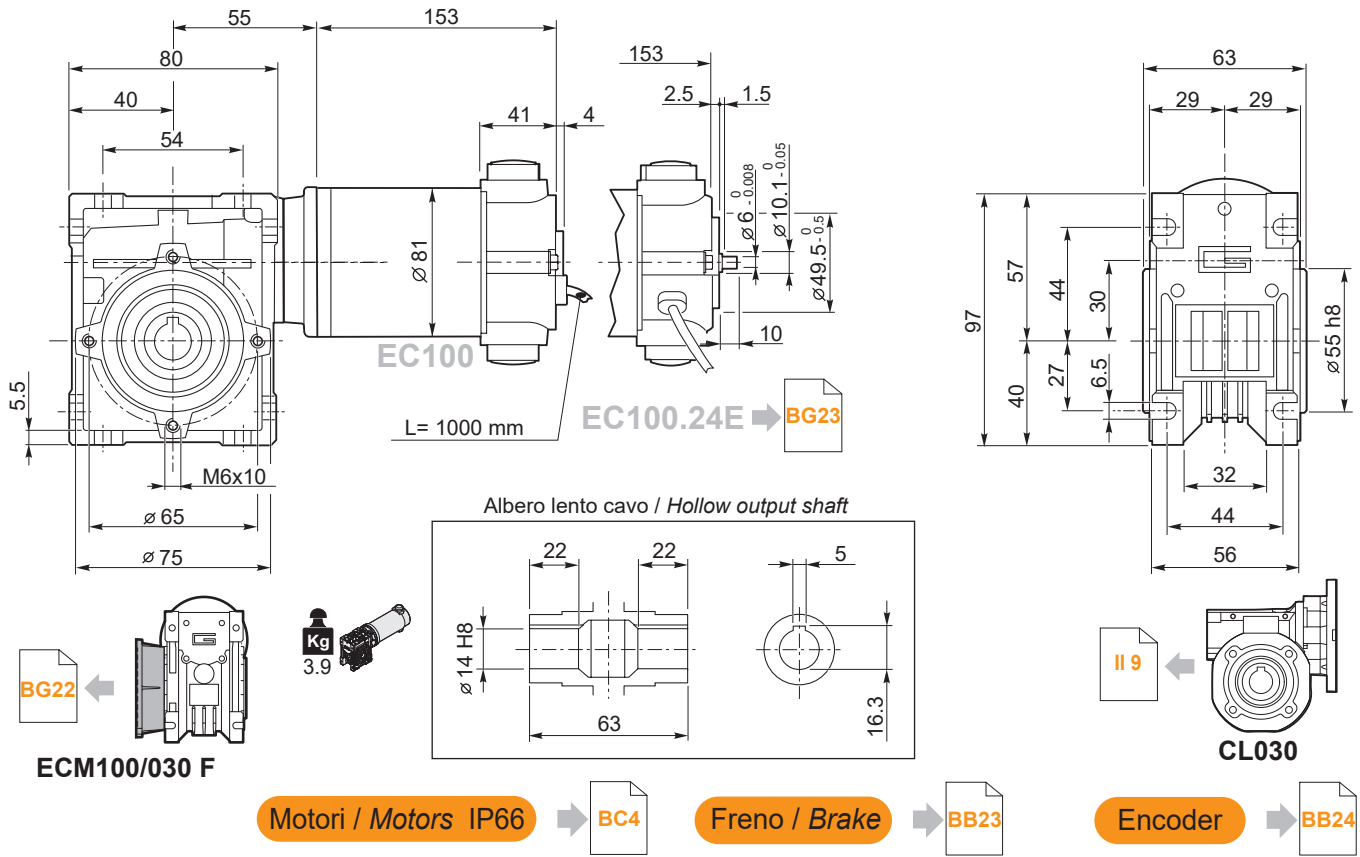

#### ECM100/040 U

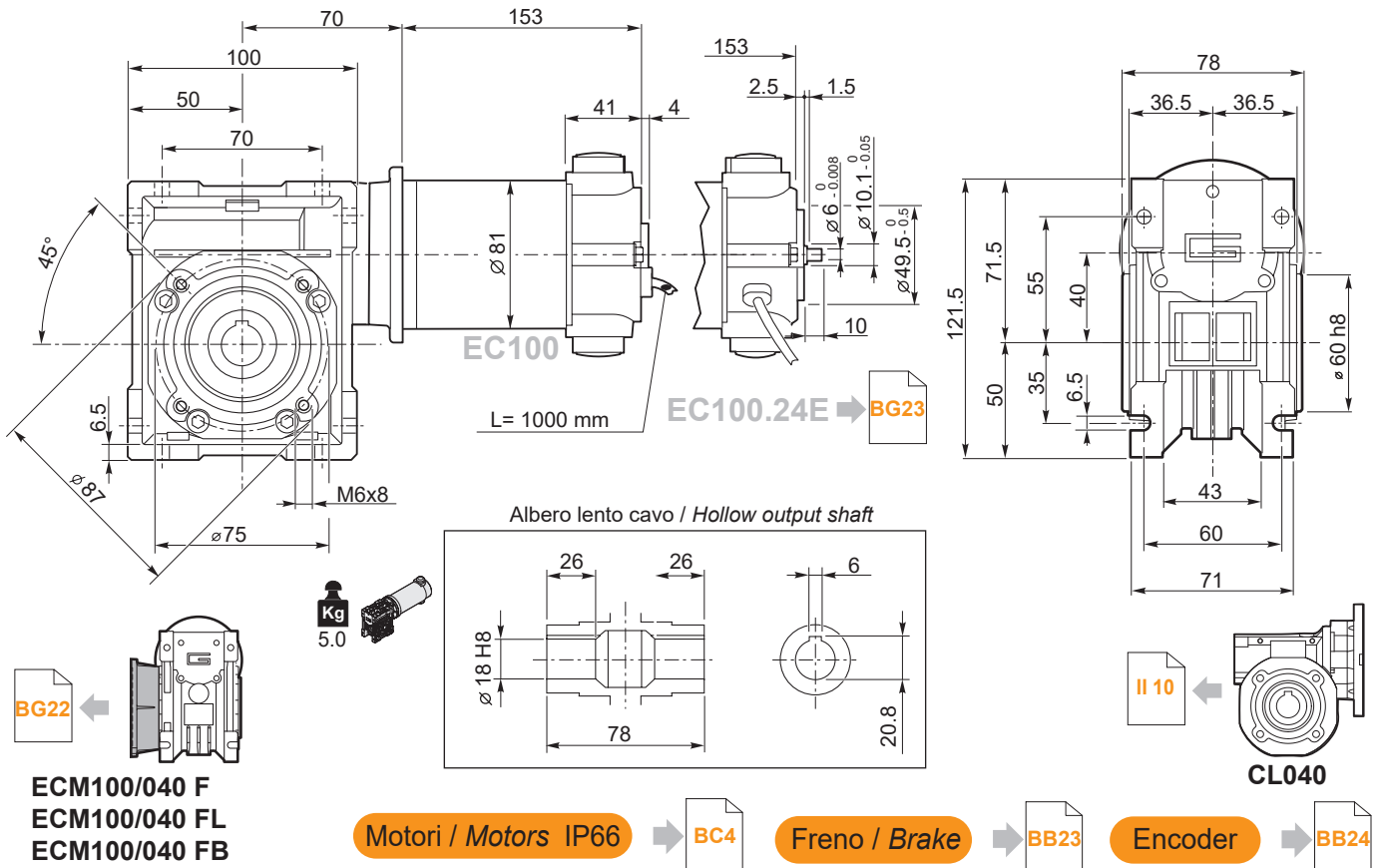

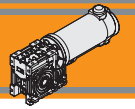

Dimensioni

Dimensions

ECM180/026 U

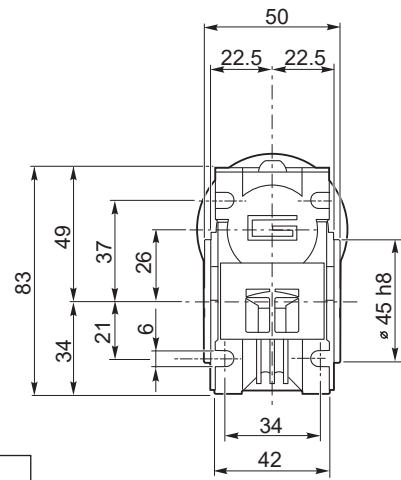
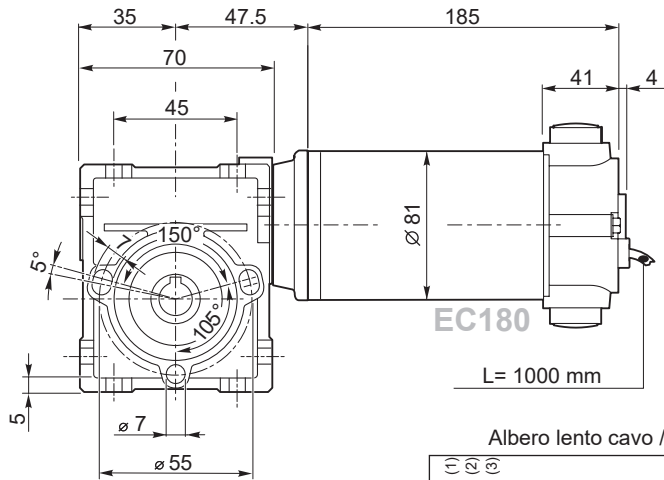

Albero lento cavo / Hollow output shaft

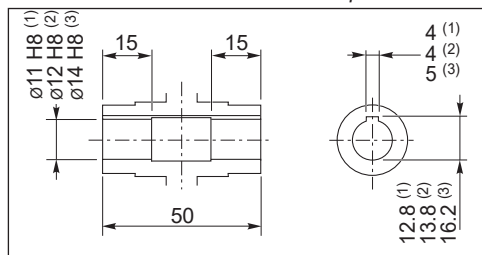

- (1): ECM 180/026 (D11)
- (2): ECM 180/026
- (3): ECM 180/026 (D14)



ECM180/026 F...

Motori / Motors IP66



Freno / Brake



Encoder

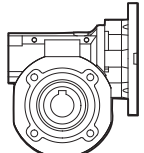

CL026

ECM180/030 U

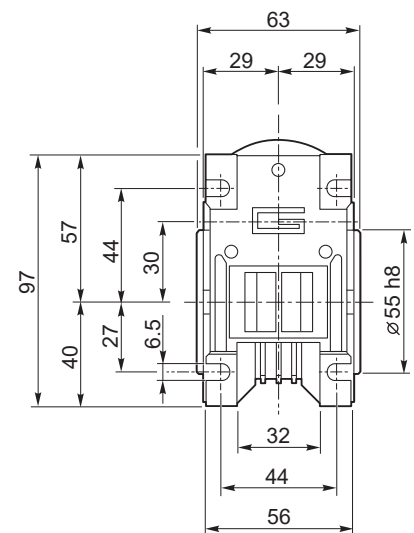
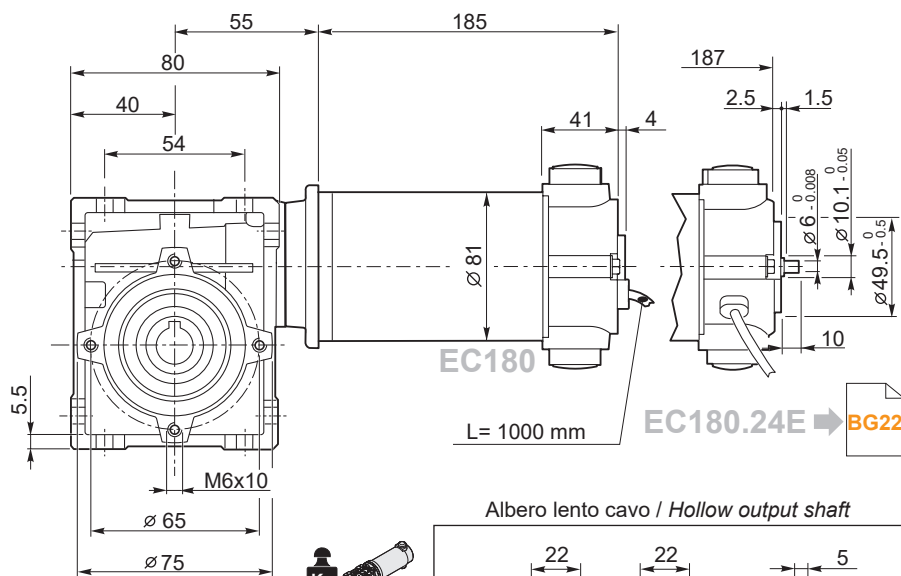

Albero lento cavo / Hollow output shaft

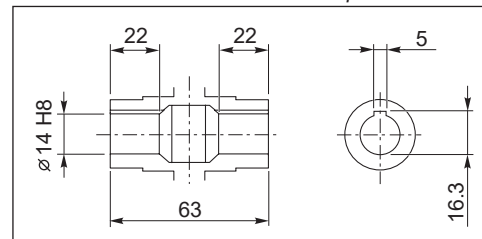

ECM180/030 F

Motori / Motors IP66



Freno / Brake



Encoder

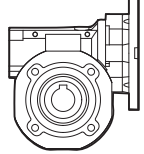

CL030

DC

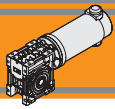

### Dimensioni

### Dimensions

#### ECM180/040 U

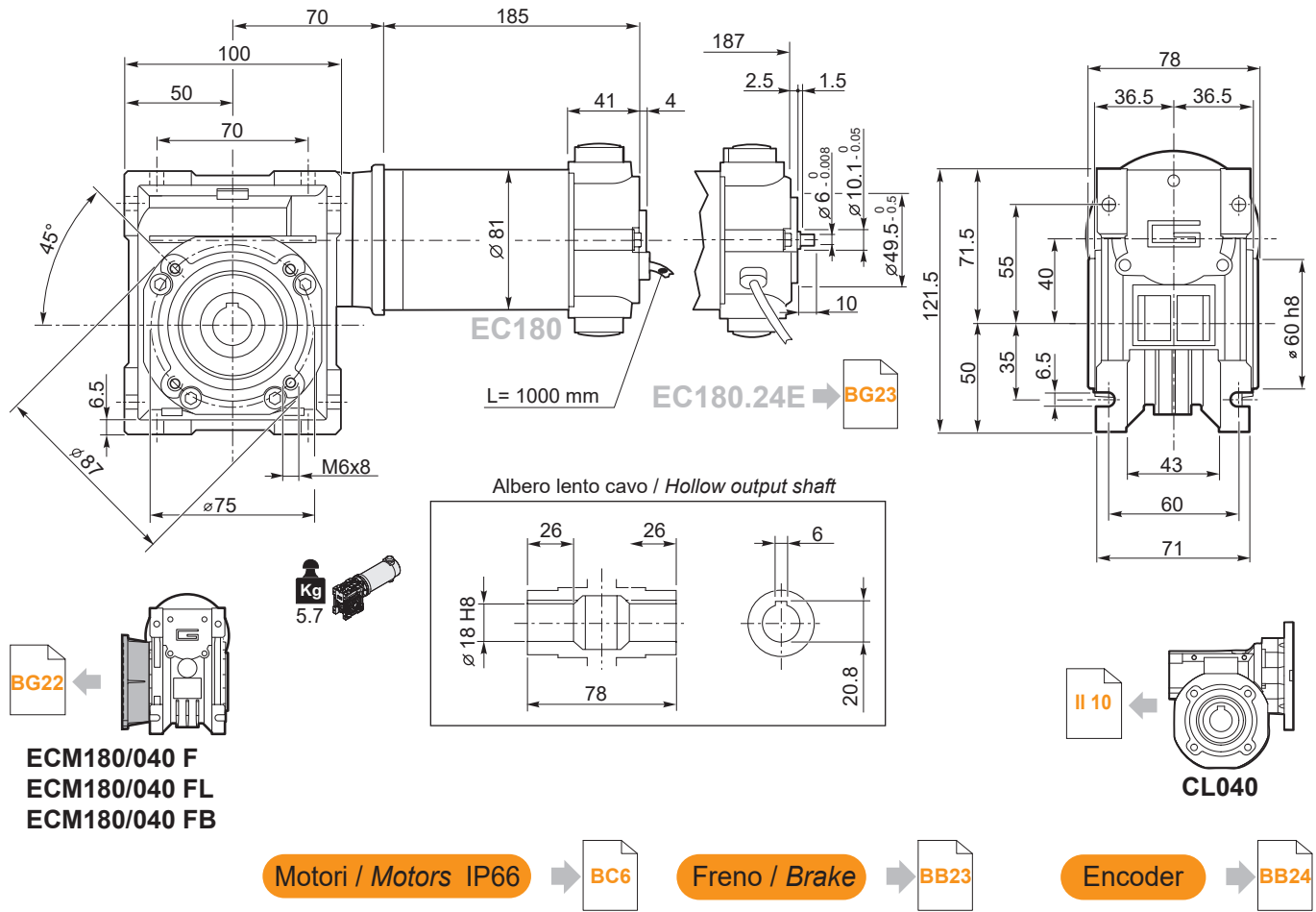



Dimensioni

Dimensions

ECM250/030 U

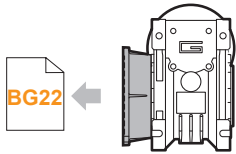
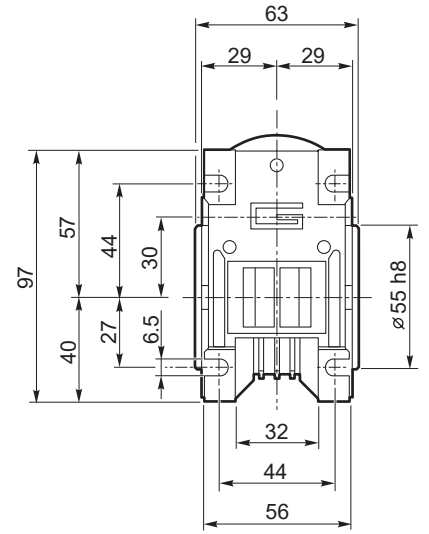
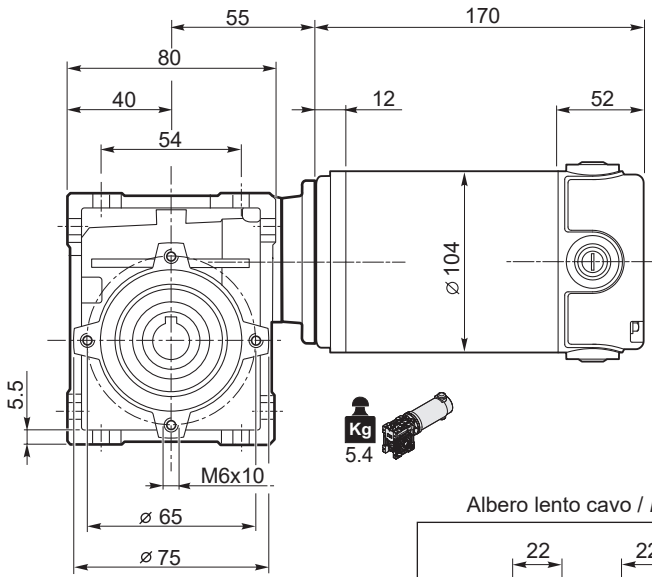

ECM250/030 F

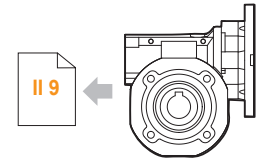
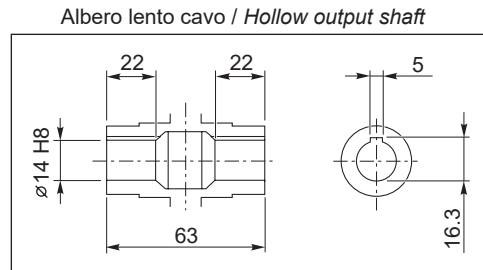

CL030

Motori / Motors IP66

BC8

ECM250/040 U

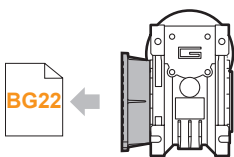
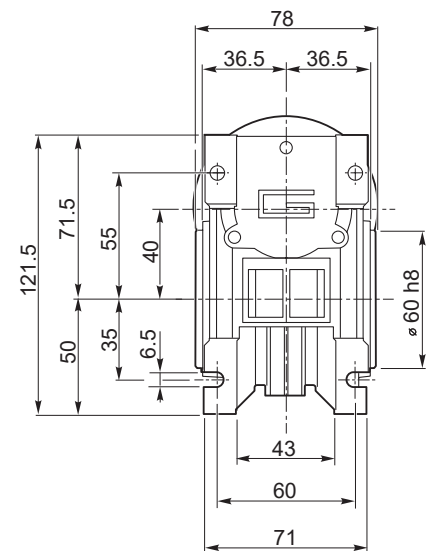
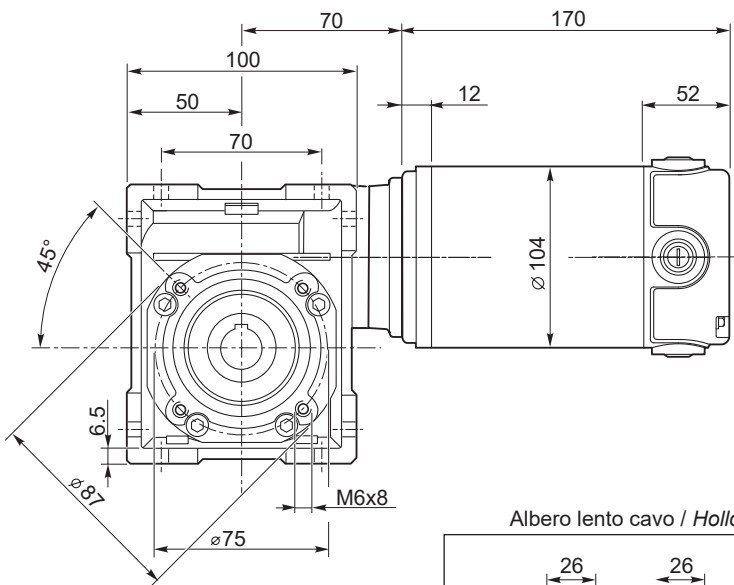

ECM250/040 F  
ECM250/040 FL  
ECM250/040 FB

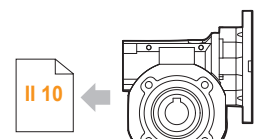
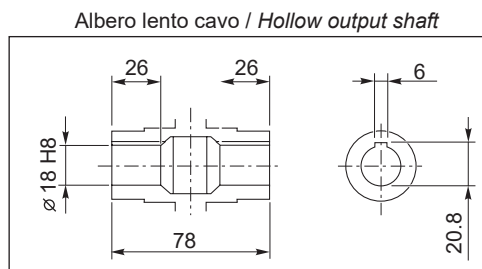

CL040

Motori / Motors IP66

BC8

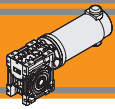

### Dimensioni

### Dimensions

#### ECM350/030 U

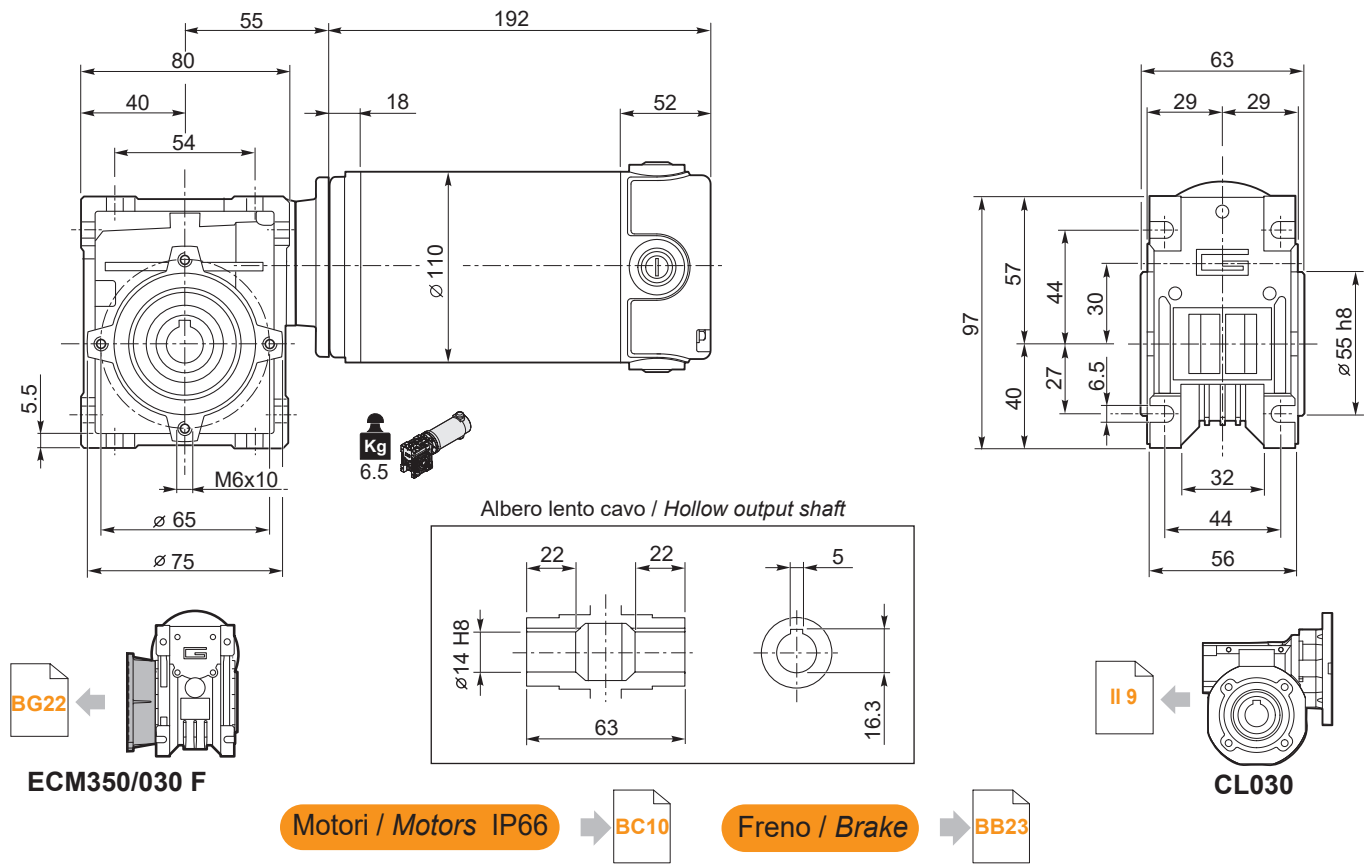

#### ECM350/040 U

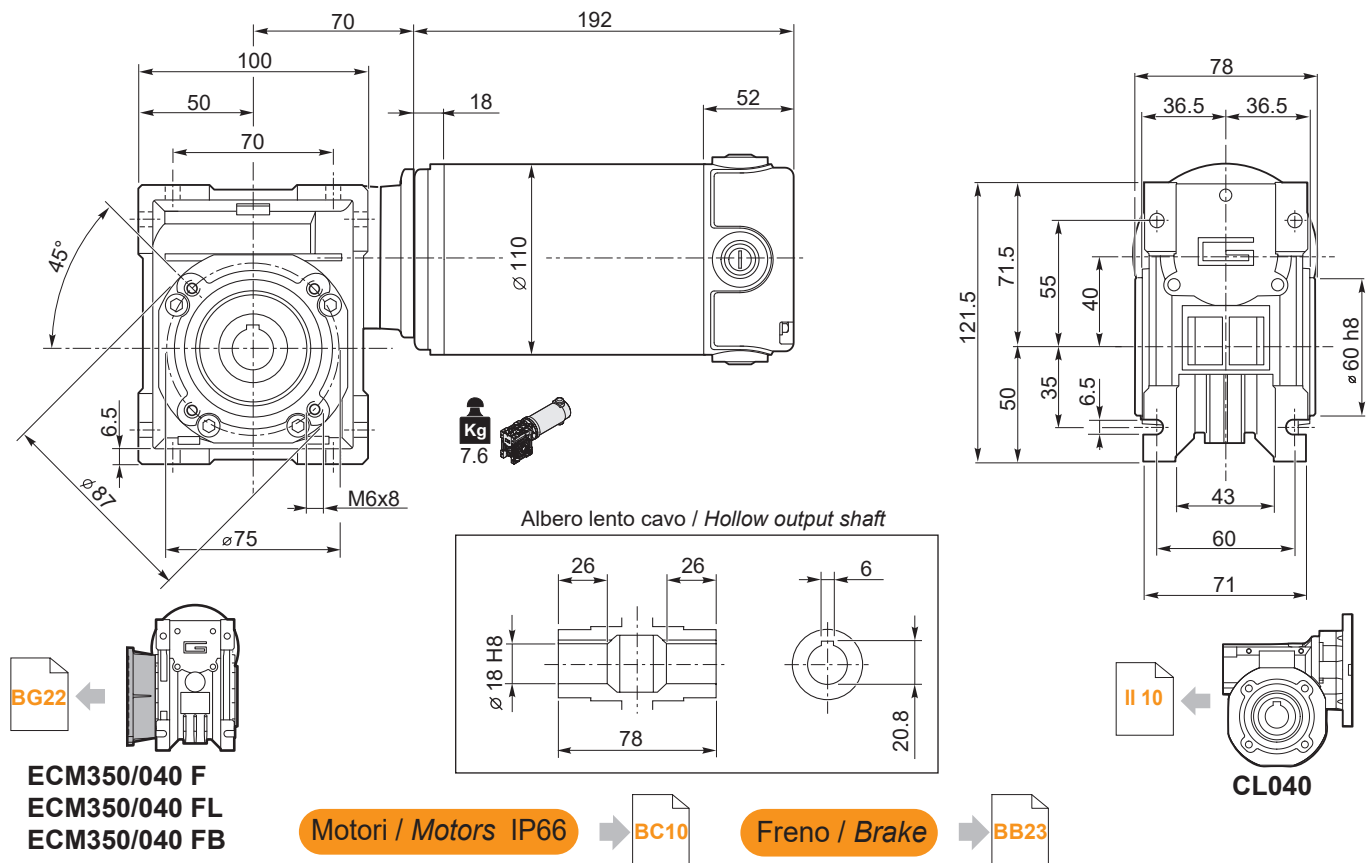



**Dimensioni**

**Dimensions**

**ECM600/040 U**

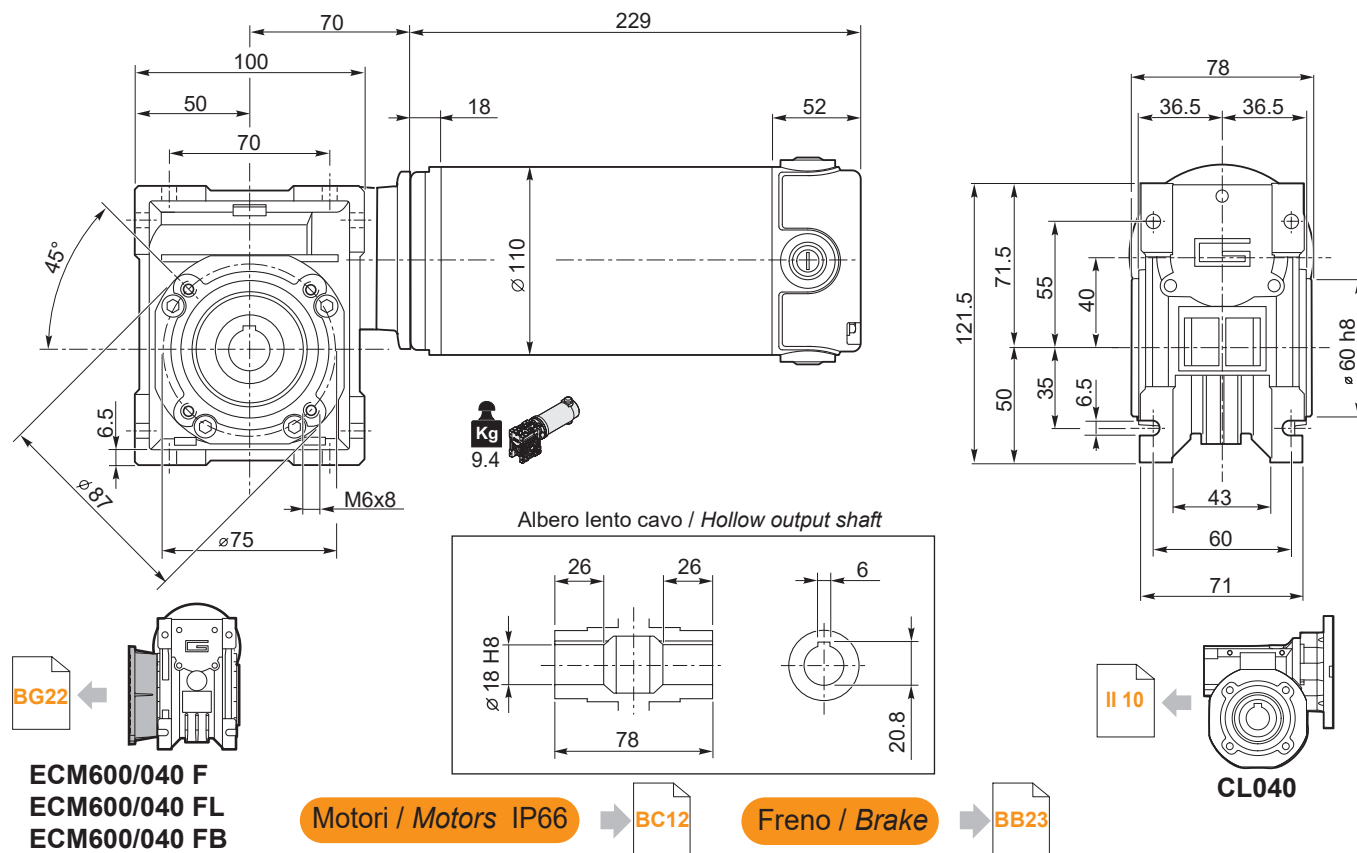

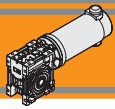

**Dimensioni**

**Dimensions**

**NDCM.../.... F... - ECM.../... F... Flange uscita / Output flanges**

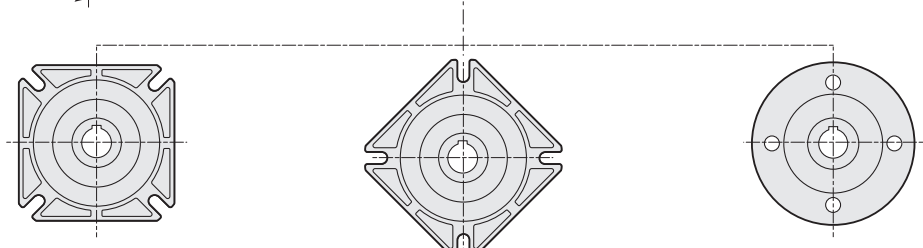
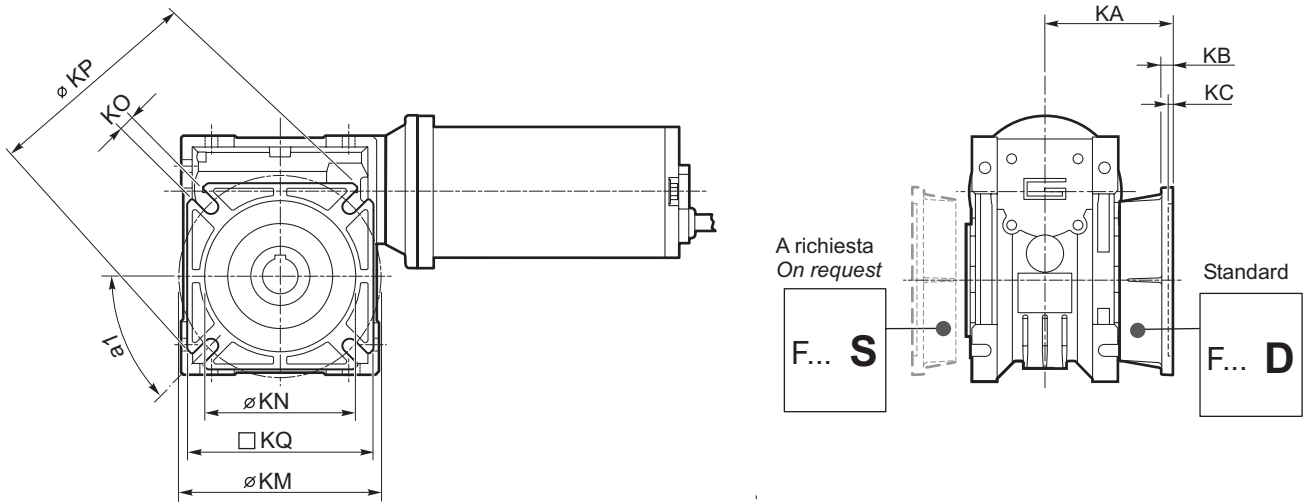

- ..CM026 ../. F
- ..CM026 ../. F28
- ..CM026 ../. F30
- ..CM026 ../. F30S
- ..CM030 ../. F..
- ..CM040 ../. F..
- ..CM026 ../. F30C
- ..CM026 ../. F30SC
- ..CM026 ../. F100

	CM..F						CM..F28						CM..F30						CM..F30S <sup>(1)</sup>														
	a1	KA	KB	KC	KM	KN <sub>H8</sub>	KO	KP	KQ	KA	KB	KC	KM	KN <sub>H8</sub>	KO	KP	KQ	KA	KB	KC	KM	KN <sub>H8</sub>	KO	KP	KQ	KA	KB	KC	KM	KN <sub>H8</sub>	KO	KP	KQ
026 (D11)	45°	45	6	4.5	55-69	40	6.5	75	70	44	6.5	5	56-64	40	6.5	70	60	48	6.5	5	68	50	6.5	80	70	50	8.5	7	68	50	6.5	80	70
026 (D14)							(n.4)																										

(1): F30S eseguita con F30 e distanziale di spessore 2 mm / F30S made with F30 and spacer with 2mm thickness

	CM..F30C						CM..F30SC <sup>(2)</sup>						CM..F100												
	a1	KA	KB	KC	KM	KN <sub>H8</sub>	KO	KP	KQ	KA	KB	KC	KM	KN <sub>H8</sub>	KO	KP	KQ	KA	KB	KC *	KM	KN <sub>h7</sub>	KO	KP	KQ
026 (D11)	-	48	6.5	7	68	50	6.5	80	70	50	8.5	7	68	50	6.5	80	70	51.5	8	2 *	86	45	6.5	100	-
026 (D14)																									

(2): F30SC eseguita con F30C e distanziale di spessore 2 mm / F30SC made with F30C and spacer with 2mm thickness

\*: Centraggio maschio / Male centering diameter

CM	CM..F						CM..FB						CM..FL												
	a1	KA	KB	KC	KM	KN <sub>H8</sub>	KO	KP	KQ	KA	KB	KC	KM	KN <sub>H8</sub>	KO	KP	KQ	KA	KB	KC	KM	KN <sub>H8</sub>	KO	KP	KQ
030	45°	54.5	6	4	68	50	6.5(n.4)	80	70	—	—	—	—	—	—	—	—	—	—	—	—	—	—	—	—
040	45°	67	7.5	4	80-95	60	9(n.4)	110	95	80	8.5	5	115-125	95	9.5(n.4)	140	112	97	7.5	4.5	80-95	60	9 (n.4)	110	95





Dimensioni

Dimensions

EC100.24E  
EC180.24E

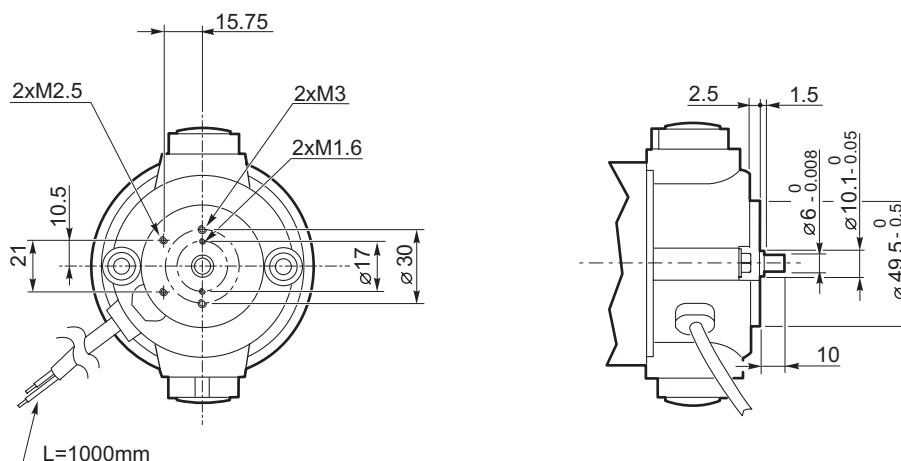

Opzioni

Options

**VS** - Vite sporgente / Extended input shaft

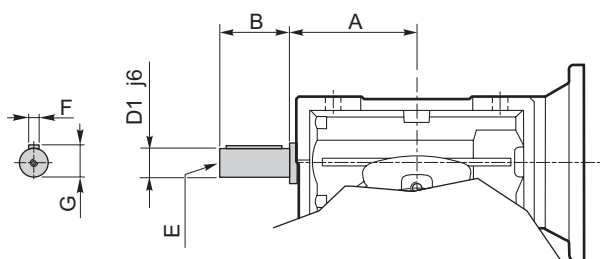

	A	B	D <sub>1</sub> j6	E	F	G
CM 030	45	20	9	M4	3	10.2
CM 040	53	23	11	M5	4	12.5

Costruito su richiesta  
Built on request

Accessori

Accessories

**SC** - Safety cover

**WD** - Kit washdown cover

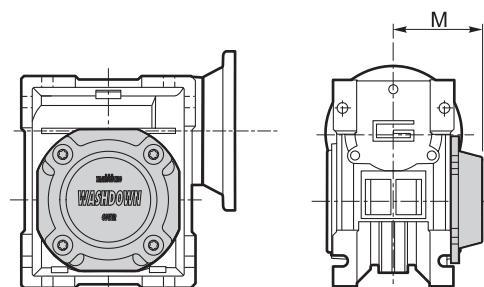
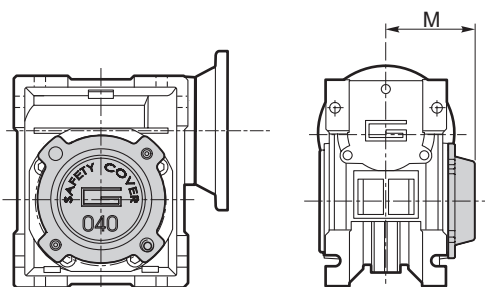

	M
CM 030	47
CM 040	54.5

	M
CM 030	48
CM 040	55.5

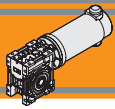

Accessori

Accessories

Albero lento

Output shaft

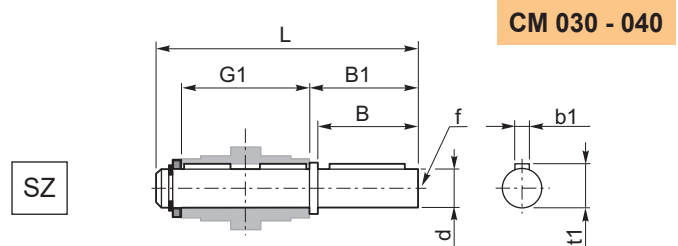
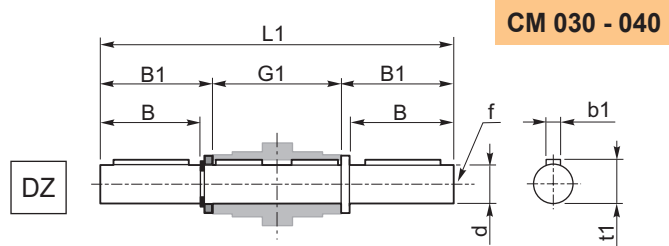

	d h7	B	B1	G1	L	L1	f	b1	t1
CM 030	14	30	32.5	63	102	128	M6	5	16
CM 040	18	40	43	78	128	164	M6	6	20.5

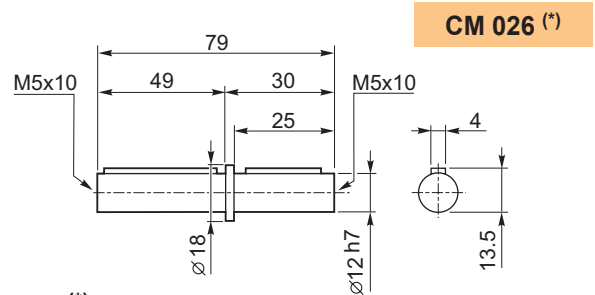

(\*)  
Nota: disponibile solo per cavo uscita Ø12  
Note: available for output hollow shaft Ø12 only

Braccio di reazione

Torque arm

	K1	G	KG	KH	R
CM 030	85	14	23	8	15
CM 040	100	14	31	10	18

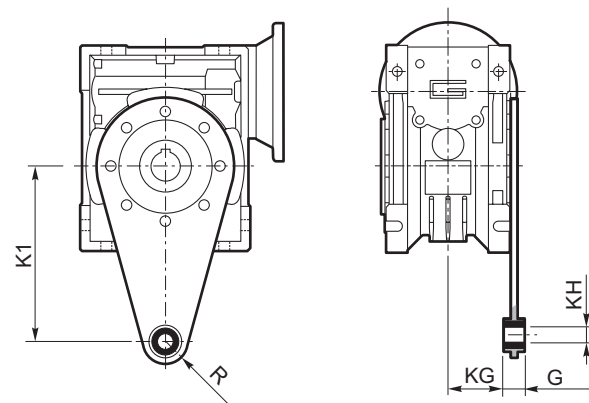

 **TRANSTECNO SRL  
HEADQUARTERS**

Company subject to the management  
and coordination of INTERPUMP GROUP SPA  
Via Caduti di Sabbiano, 11/D-E  
40011 Anzola dell'Emilia (BO)  
ITALY  
T+39 051 64 25 811  
F +39 051 73 49 43  
sales@transtecno.com  
[www.transtecno.com](http://www.transtecno.com)

 **TRANSTECNO®**  
the modular gearmotor

MEMBER OF INTERPUMP GROUP



 **HANGZHOU TRANSTECNO POWER  
TRANSMISSIONS CO LTD**  
No.4 Xiuyan Road Fengdu Industry Zone  
Pingyao Town Yuhang District  
Hangzhou City, Zhejiang Province  
311115 - CHINA  
T +86 571 86 92 02 60  
F +86 571 86 92 18 10  
info-china@transtecno.cn  
[www.transtecno.cn](http://www.transtecno.cn)

 **MA TRANSTECNO S.A.P.I. DE C.V.**  
Av. Mundial # 176, Parque Industrial  
JM Apodaca, Nuevo León,  
C.P. 66600 - MEXICO  
T +52 8113340920  
info@transtecno.com.mx  
[www.transtecno.com.mx](http://www.transtecno.com.mx)

 **TRANSTECNO IBÉRICA  
THE MODULAR GEARMOTOR, S.A.**  
Carrer de la Ciència, 45  
08840 Viladecans (Barcelona) - SPAIN  
T +34 931 598 950  
info@transtecno.es  
[www.transtecno.es](http://www.transtecno.es)

 **TRANSTECNO B.V.**  
Siliciumweg 32  
3812 SX Amersfoort - NETHERLANDS  
T +31(0) 33 45 19 505  
F +31(0) 33 45 19 506  
info@transtecno.nl  
[www.transtecno.nl](http://www.transtecno.nl)

 **TRANSTECNO AANDRIJFTECHNIEK B.V.**  
Siliciumweg 32  
3812 SX Amersfoort - NETHERLANDS  
T +31 (0) 33 20 4 7 006  
info@transtecnoaandrijftechnik.nl  
[www.transtecnoaandrijftechnik.nl](http://www.transtecnoaandrijftechnik.nl)

 **TRANSTECNO USA**  
8 Creek Parkway,  
Boothwyn PA 19061-8136 - UNITED STATES  
T +1 (610) 4970154  
F +1 (610) 497 6085

**TRANSTECNO USA – WEST COAST BRANCH**  
14561 Fryelands Blvd SE  
Monroe, WA 98272 - UNITED STATES  
T +1 360-863-1300  
F +1 360-863-1303  
usaoffice@transtecno.com  
[www.transtecno.com](http://www.transtecno.com)

 **TRANSTECNO CANADA**  
51 B Caldari Road Unit 10  
Vaughan, ON L4K 4G3 - CANADA  
T +1 905 761 0762  
F +1 905 761 9265  
canadaoffice@transtecno.com  
[www.transtecno.com](http://www.transtecno.com)

 **TRANSTECNO CHILE-PERU**  
Av. Los Libertadores 41  
Parque Industrial - Los Libertadores 16.500  
Santiago, Colina - CHILE  
T +56 2 29633870

Carretera Panamericana Sur KM 29.5,  
Interior I-3, Z.I. Lurin - PERU  
T +51 1 3546259 / + 51 1 3434231  
chileoffice@transtecno.com  
[www.transtecno.com](http://www.transtecno.com)

 **TRANSTECNO INDIA**  
#6A, Sipcot Industrial complex, Phase-1, Elasagiri Road  
Hosur - 635126 Tamilnadu - INDIA  
T +91 4344 274434  
M +91 81443 88800

**TRANSTECNO INDIA – NORTH BRANCH**  
Plot No: 3 A, Sector 2, IIE, Sidcul, Pantnagar  
U.S. Nagar, Uttarakhand - 263153 - INDIA  
indiaoffice@transtecno.com  
[www.transtecno.com](http://www.transtecno.com)

 **SALES OFFICE BRAZIL**  
Rua Dr. Freire Alemão 155 / 402 - CEP. 90450-060  
Auxiliadora Porto Alegre RS - BRAZIL  
T +55 51 3251 5447  
F +55 51 3251 5447  
M +55 51 811 45 962  
braziloffice@transtecno.com  
[www.transtecno.com.br](http://www.transtecno.com.br)

 **SALES OFFICE OCEANIA**  
Unit 5, 12 Nyholt Drive, Yatala 4207  
Queensland - AUSTRALIA  
T +61 07 3800 0103  
M +61 04 38060997  
oceaniaoffice@transtecno.com  
[www.transtecno.com.au](http://www.transtecno.com.au)

 **SALES OFFICE SOUTH KOREA**  
772-41, Bongdong-ro, Bongdong-eup, Wanju-goon  
Chonbuk, 55313  
SOUTH KOREA  
T +82 70 8867 8897  
F +82 504 199 2107  
M +82 10 5094 2107  
koreaoffice@transtecno.com  
[www.transtecno.com](http://www.transtecno.com)

[www.minitecno.com](http://www.minitecno.com)  
[www.transtecno.com](http://www.transtecno.com)