

NEW
SM Squared Line
Induction Motor



**La nuova gamma di
motori AC**

DIMENSIONI RIDOTTE
rispetto allo standard

GRADO DI PROTEZIONE IP66

PRESTAZIONI SUPERIORI
grazie al lamierino magnetico
M800-50 A (IE1) e M400-50 A (IE3)

**The new range of
AC motors**

REDUCED DIMENSIONS
compared to the standard

IP66 PROTECTION RATING

SUPERIOR PERFORMANCE
thanks to the magnetic plates
M800-50 A (IE1) and M400-50 A (IE3)

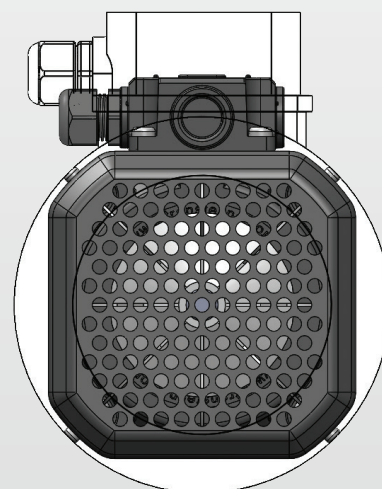
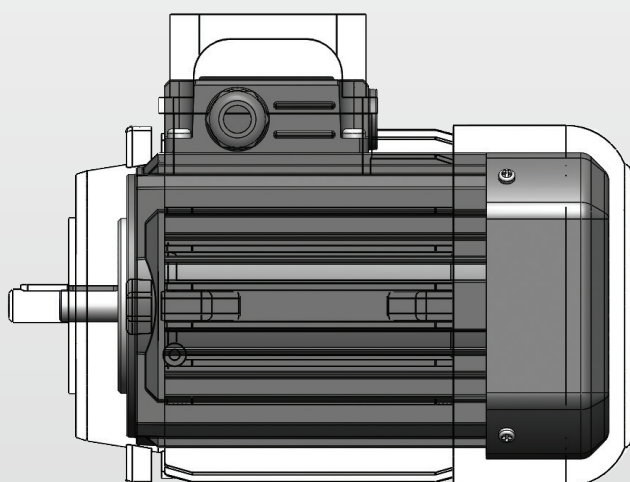

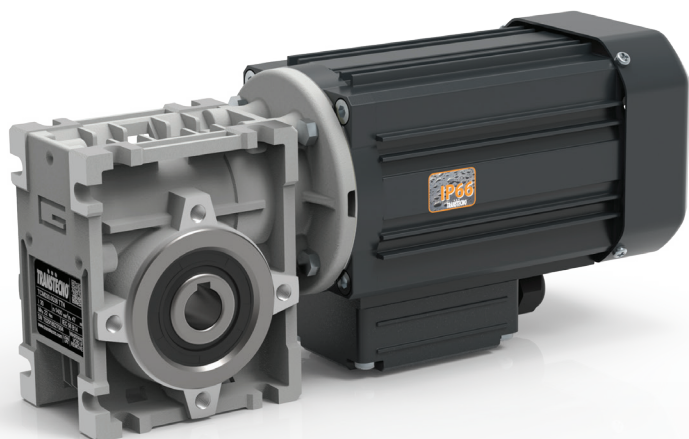

NEW
SM Squared Line
Induction Motor



CARATTERISTICHE ELETTRICHE

- Potenze: 0,025 ~ 2,2 kW
- 2-4-6 poli
- Alimentazione monofase e trifase 50-60 Hz
- Idoneo per uso inverter
- Protettore termico bimetallico PTO
- Classe di isolamento F
- Certificazione CE, UL/CSA
- Elevata efficienza grazie al lamierino magnetico M800-50 A (motori IE1) e M400-50 A (motori IE3)



ELECTRICAL FEATURES

- Powers: 0.025 ~ 2.2 kW
- 2-4-6 poles
- Single-phase and three-phase 50-60 Hz power supply
- Inverter use
- PTO bimetal thermal protector
- F class insulation
- CE, UL / CSA certificate
- High efficiency thanks to the magnetic plates M800-50 A (IE1 motors) and M400-50 A (IE3 motors)



CARATTERISTICHE MECCANICHE

- Grandezze disponibili: 50 ~ 90
- Carcasa in lega di alluminio estruso (EN AW- 6060 T5) con superficie anodizzata nera
- Grado di protezione IP66 ottenuto grazie a:
 - O-Ring
 - Paraoli
 - 8 fori di attacco non passanti
- Flangia B14
- Versioni TENV e TEFC
- Disponibile versione autofrenante, servoventilata e con encoder

MECHANICAL FEATURES

- Available sizes: 50 ~ 90
- Extruded aluminum alloy (EN AW-6060 T5) casing with black anodised surface
- IP66 protection degree thanks to:
 - O-Ring
 - Seals
 - 8 non-through holes
- B14 flange
- TENV and TEFC versions
- Available versions with self-braking, servo-ventilated and encoder