

Índice	Índice	Index	Pag. Pág. Page
Características técnicas	<i>Características técnicas</i>	Technical features	G2
Clasificación	<i>Designação</i>	Classification	G2
Sentidos de rotación	<i>Sentidos de rotação</i>	Direction of rotation	G4
Nomenclatura	<i>Simbologia</i>	Legend	G4
Lubricación	<i>Lubrificação</i>	Lubrication	G5
Cargas radiales	<i>Cargas radiais</i>	Radial loads	G6
Datos de dentado	<i>Dados de dentadura</i>	Toothing data	G7
Rendimiento	<i>Rendimento</i>	Efficiency	G7
Datos técnicos	<i>Dados técnicos</i>	Technical data	G8
Motores aplicables	<i>Motores aplicáveis</i>	IEC Motor adapters	G16
Dimensiones	<i>Dimensões</i>	Dimensions	G18
Accesorios	<i>Acessórios</i>	Accessories	G32
Opciones	<i>Opções</i>	Options	G33

Esta sección substituye y anula las ediciones y revisiones previas. Si usted obtiene este catálogo a través de canales de distribución no autorizados o fuera de nuestro control, la versión en vigor no estará garantizada. **En todo caso, la versión más actualizada está disponible en nuestra página de internet www.transtecno.com**

Esta seção anula e substitui qualquer edição ou revisão precedente. Caso esta seção não seja encontrada em distribuição controlada, a atualização dos dados aqui contidos não é segura. Neste caso a versão atualizada está disponível no nosso site: www.transtecno.com

This section replaces any previous edition and revision. If you obtained this catalogue other than through controlled distribution channels, the most up to date content is not guaranteed. **In this case the latest version is available on our web site www.transtecno.com**

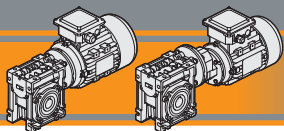

CM/CMP

Motorreductores sinfín corona
 Motores de rosca sem fim
 Wormgearmotors

60 Hz

Características técnicas

El elevado nivel de modularidad caracteriza los motorreductores sinfín corona de la serie CM y CMP; los diversos kits de entrada y salida permiten una versatilidad extrema del motorreductor. Los motorreductores de la serie CM y CMP poseen las características siguientes:

- Los tamaños 026, 030, 040, 050, 063, 075, 090 y 110 están contruidos con carcasa de aluminio. Los tamaños 130 y 150 en hierro fundido;
- Los tamaños 090, 110, 130 y 150 se suministran con rodamientos de rodillos conicos en el sinfín;
- El pre-reductor se fabrica con carcasa de aluminio;

Características técnicas

A elevada modularidade contradistingue os redutores de rosca sem fim da série CM e CMP: os vários kits de entrada e saída os tornam extremamente versáteis.

As principais características das séries CM e CMP são:

- Carcaça em alumínio nas grandezas 026, 030, 040, 050, 063, 075, 090 e 110. As grandezas 130 e 150 são construídas com carcaça em ferro fundido;
- Os tamanhos 090, 110, 130 e 150 são fornecidos com rolamentos cônicos
- Os pré estágios são contruidos com carcaça em alumínio

Technical features

The high degree of modularity is a design feature of CM and CMP wormgearmotors range thanks to a wide selection of input and output kits.

Main features of CM and CMP range are:

- Die-cast aluminum housing on sizes 026, 030, 040, 050, 063, 070, 075, 090 and 110. Cast iron housing on size 130 and 150;
- Double taper roller bearing on sizes 090, 110, 130 and 150;
- Die-cast aluminum housing on pre-stage units;

Clasificación

Designação

Classification

REDUCTORES DE SINFÍN CORONA REDUTORES DE ROSCA SEM FIM WORMGEARBOXES

REDUCTOR / REDUTOR / GEARBOX

CM	050	U	10	71	B5	SZDX	BR SX	90	M1	VS
Tipo Tipo Type	Tamaño Tamanho Size	Versión Versão Version	Relación de reducción Rapporto Ratio	IEC 	Forma constructiva Forma construtiva Version	∅ Eje de salida ∅ Eixo saída ∅ Output shaft	Braço de reacção Braço de reação Torque arm	Ángulo Ângulo Angle	Posición de montaje Pos. de montagem Mounting position	Opción Opções Options
CM 	026 026 (D11) 026 (D14) 030 040 050 063 070 075 090 110 130 150	U F...	Véase tablas Veja tabelas see tables	56.. — 132..	B5 B14	SZDX SZSX DZ	BRDX BR SX 	0° 90° 180° 270°	M1 (B3) M2 (V6) M3 (B8) M4 (V5) M6 (B6) M5 (B7)	VS
CMIS 										

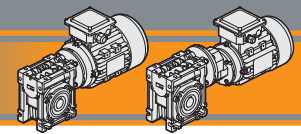

Clasificación

Designação

Classification

PREDUCTORES SINFÍN CORONA CON PRE-REDUCTOR
REDUTORES DE ROSCA SEM FIM COM PRÉ-ESTÁGIO
PRE-STAGE WORMGEARBOXES

REDUCTOR / REDUTOR / GEARBOX												
CMP	063/050	U	90	63	B14	SZDX	BRSX	90	P4	M1	VS	
Tipo Tipo Type	Tamaño Tamanho Size	Versión Versão Version	Relación de reducción Rapporto Ratio	IEC 	Forma constructiva Forma construtiva Version	∅ Eje de salida ∅ Eixo saída ∅ Output shaft	Brazo de reacción Braço de reação Torque arm	Ángulo Ângulo Angle	Posición de montaje Pos. de montagem Mounting position	Opciones Opções Options	Opciones Opções Options	
CMP 	056/030 056/040 063/040 063/050 063/063 071/050 071/063 071/070 071/075 071/090 080/063 080/070 080/075 080/090 080/110 080/130 090/070 090/075 090/090 090/110 090/130	U F...	Véase tablas Veja tabelas see tables	56.. — 80..	B5 B14	SZDX SZSX DZ *	BRDX BRSX	0° 90° 180° 270°	P1 P2 P3 (standard) P4	M1 (B3) M2 (V6) M3 (B8) M4 (V5) M6 (B6) M5 (B7)	VS	

CM/CMP

* NOTA: el brazo de reacción se suministra desmontado.
 * NOTA: o braço de reação é fornecido desmontado.
 NOTE: the torque arm will be supplied not assembled.

Relación de reducción Versão Redutor Gearbox Version U F...D F...S	Eje de salida Eixo de saída Output shaft SZDX SZSX DZ	Brazo de reacción Braço de reação Torque arm * BRDX BRSX	Ángulo Ângulo Angle
--	---	---	-----------------------------------

MOTOR / MOTOR / MOTOR					
0.75kW	4p	3ph	230/400V	60Hz	T1
Potencia Potência Power	Polos Pólos Poles	Fases Fases Phases	Tensión Tensão Voltage	Frecuencia Frequência Frequency	Posición caja de bornes Pos. Conexão Terminal box pos.
Véase tablas Veja tabelas see tables	2p 4p 6p 8p	1ph 3ph	230/400V 220/380V ... 230V ...	60Hz	T1 (Std)

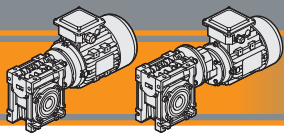

Sentidos de rotación

Sentidos de rotação

Direction of rotation

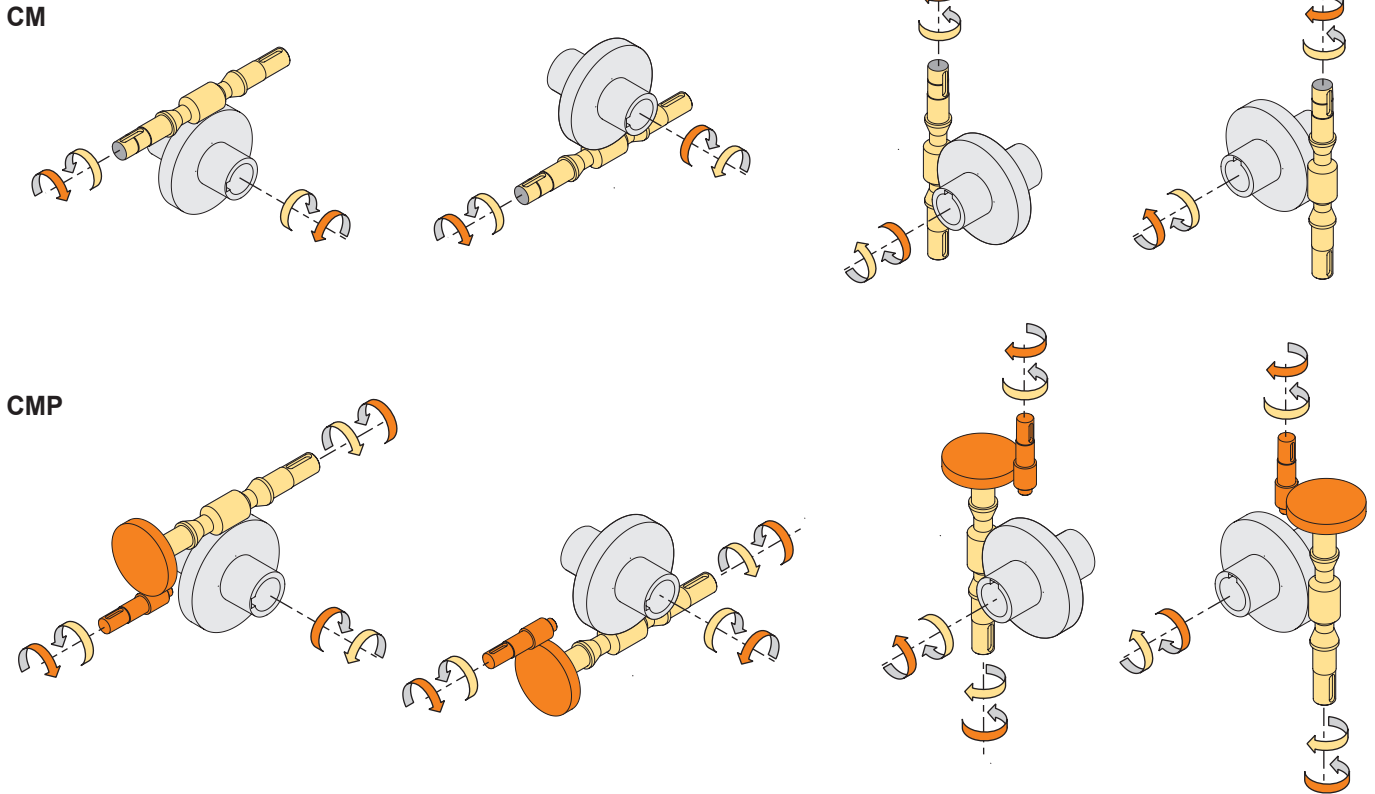

Nomenclatura

Simbologia

Legend

n_1	[rpm]	Velocidad de entrada / <i>Velocidade na entrada</i> / Input speed
n_2	[rpm]	Velocidad de salida / <i>Velocidade na saída</i> / Output speed
i		Relación de reducción / <i>Relação de redução</i> / Ratio
P_1	[kW]	Potencia en la entrada / <i>Potência da entrada</i> / Input power
M_2	[Nm]	Par en la salida en función de P_1 / <i>Torque na saída em função de P_1</i> / Output torque referred to P_1
P_{n1}	[kW]	Potencia nominal en la entrada / <i>Potência nominal na entrada</i> / Nominal input power
M_{n2}	[Nm]	Par nominal en la salida en función de P_{n1} / <i>Torque nominal na saída em função de P_{n1}</i> / Nominal output torque referred to P_{n1}
sf		Factor de servicio / <i>Fator de serviço</i> / Service factor
R_d	%	Rendimiento estático / <i>Rendimento estático</i> / Dynamic efficiency
R_s	%	Rendimiento estático / <i>Rendimento statico</i> / Static efficiency
R_2	[N]	Carga radial admisible en la salida / <i>Carga radial admissível na saída</i> / Maximum output radial load
A_2	[N]	Carga axial admisible en la salida / <i>Carga axial admissível na saída</i> / Maximum output axial load
Z		Número de entradas del tornillo / <i>Número de princípios dos parafusos</i> / Worm starts
β		Ángulo de hélic / <i>Ângulo de hélice</i> / Helix angle

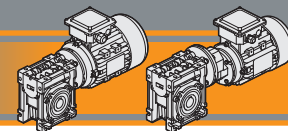

Lubricación

Lubrificação

Lubrication

Todos los motorreductores sinfín corona son previamente lubricados con aceite sintético con grado de viscosidad 320, por lo tanto, pueden ser instalados en cualquier posición de montaje y no requieren mantenimiento.

Todos os motoredutores são fornecidos completos de lubrificante sintético de viscosidade 320, portanto, podem ser instalados em qualquer posição de montagem e não necessitam de manutenção.

Permanent synthetic oil long-life lubrication (viscosity grade 320) makes it possible to use the gearmotors in all mounting positions; for this reason they can be installed in any assembly position and do not require maintenance.

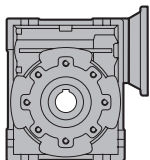

CM	Cantidad de aceite (litros) / Quantidade de óleo (litros) / Oil quantity (litres)					
	M1 (B3)	M3 (B8)	M6 (B6)	M5 (B7)	M4 (V5)	M2 (V6)
130	4.5	3.3	3.5	3.5	4.5	3.3
150	7	5.1	5.4	5.4	7	5.1

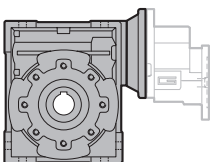

CMP	Cantidad de aceite (litros) / Quantidade de óleo (litros) / Oil quantity (litres)					
	M1 (B3)	M3 (B8)	M6 (B6)	M5 (B7)	M4 (V5)	M2 (V6)
080/130 - 090/130	4.5	3.3	3.5	3.5	4.5	3.3

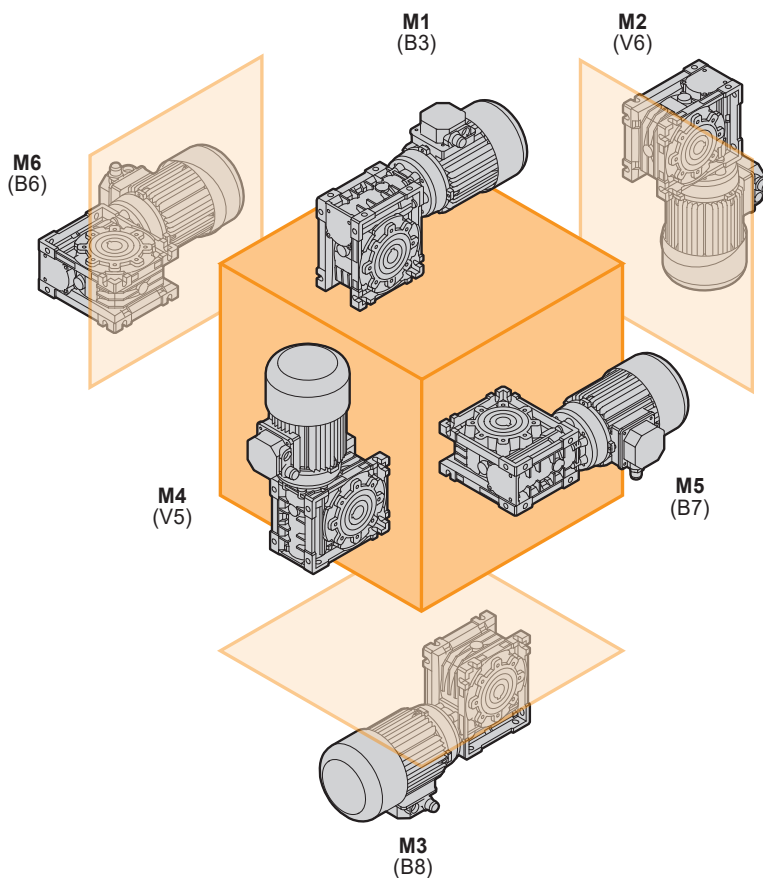

CM_CMP 130 - 150

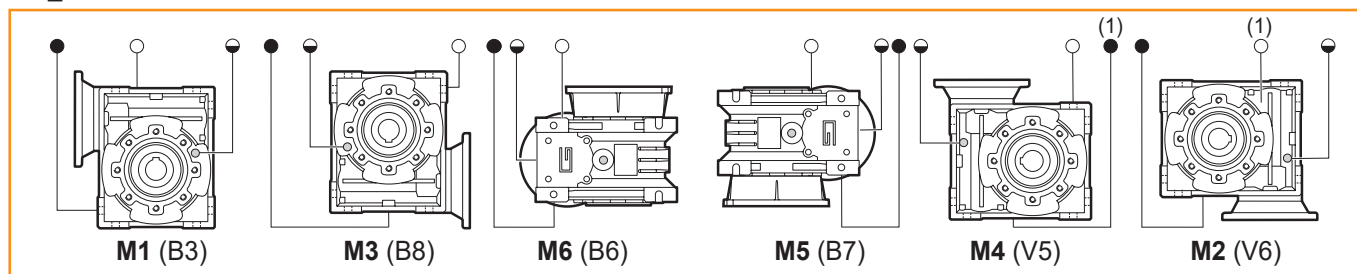

(standard)

(1): Tapón en posición trasera
 Válvula na posição posterior
 Plug in backside position

- Tapón de purga y tapón de llenado del aceite
 Válvula de Respiro e tampa de preenchimento / Breather and filling plug
- ◐ Nivel del aceite / Nivel de óleo / Oil level plug
- Tapon de drenado del aceite / Oil drain plug

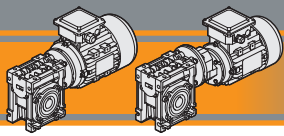

Cargas radiales

Cargas radiais

Radial loads

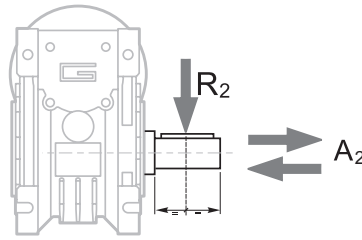

$$A_2 = R_2 \times 0.2$$

n ₂ [min ⁻¹]	R ₂ [N]										
	CM026	CM030	CM040	CM050	CM063	CM070	CM075	CM090	CM110	CM130	CM150
187	400	674	1264	1770	2445	2613	2824	3161	5058	5732	6962
140	490	743	1392	1949	2692	2878	3110	3481	5570	6313	7663
93	580	851	1596	2234	3085	3298	3564	3990	6384	7235	8771
70	610	936	1754	2456	3392	3626	3918	4386	7018	7953	9654
56	610	1008	1890	2646	3654	3906	4221	4725	7560	8567	10400
47	610	1069	2004	2805	3874	4141	4475	5009	8014	9083	11051
35	610	1179	2210	3095	4273	4568	4937	5526	8842	10021	12163
28	610	1270	2381	3334	4603	4921	5318	5953	9524	10794	13103
23	610	1356	2542	3559	4915	5254	5678	6356	10170	11526	13924
18	610	1471	2759	3862	5334	5702	6162	6897	11036	12507	15182
14	610	1600	3000	4200	5800	6200	6700	7500	12000	13600	16500

CM... /030 CMP... /040 CMP... /050 CMP... /063 CMP... /070 CMP... /075 CMP... /090 CMP... /110 CMP... /130

Cuando la carga radial no se aplica en el punto medio del eje, es necesario calcular la carga efectiva a través la siguiente fórmula:

Quando a carga radial resultante não é aplicada na linha mediana da eixo, é preciso calcular aquela efetiva com a seguinte fórmula:

When the resulting radial load is not applied on the centre line of the shaft it is necessary to calculate the effective load with the following formula:

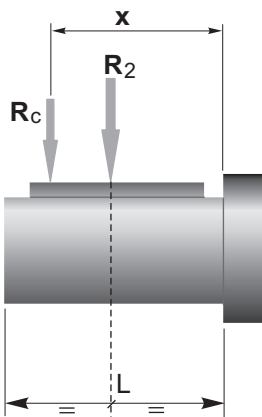

	CM	CM / CMP									
	026	030	040	050	063	075	090	110	130	150	
a	56	65	84	101	120	131	182	176	188	215	
b	43	50	64	76	95	101	122	136	148	174	
R _{2MAX}	610	1600	3000	4200	5800	6700	7500	12000	13600	16500	

$$R_c = \frac{R_2 \cdot a}{(b + x)} \leq R_{2MAX}$$

$$R \leq R_c$$

a, b = valores dados en la tabla
 a, b = valores referidos na tabela
 a, b = values given in the table

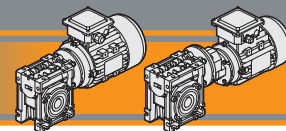

Datos de dentado

Dados de dentadura

Toothing data

	Datos del engranaje sinfín corona Dados do binário de parafusos coroa Worm wheel data	Relación de reducción / Relação / Ratio											
		5	7.5	10	15	20	25	30	40	50	60	80	100
CM026	Z	6	4	3	2	2		1	1	1	1		
	β	34° 35'	24° 41'	19° 1'	12° 57'	10° 30'		6° 33'	5° 17'	4° 26'	3° 49'		
CM030	Z	6	4	3	2	2	2	1	1	1	1	1	1
	β	27° 4'	24° 28'	18° 50'	12° 49'	10° 23'	8° 43'	6° 29'	5° 14'	4° 23'	3° 46'	2° 57'	2° 25'
CM040	Z	6	4	3	2	2	2	1	1	1	1	1	1
	β	34° 19'	24° 28'	18° 50'	12° 49'	10° 23'	8° 43'	6° 29'	5° 14'	4° 23'	3° 46'	2° 57'	2° 25'
CM050	Z	6	4	3	2	2	2	1	1	1	1	1	1
	β	33° 37'	23° 54'	18° 23'	12° 29'	10° 6'	8° 28'	6° 19'	5° 5'	4° 15'	3° 39'	2° 51'	2° 20'
CM063	Z	6	4	3	2	2	2	1	1	1	1	1	1
	β	34° 23'	24° 31'	18° 53'	12° 50'	10° 24'	8° 44'	6° 30'	5° 14'	4° 23'	3° 47'	2° 57'	2° 25'
CM075	Z		4	3	2	2	2	1	1	1	1	1	1
	β		26° 17'	20° 20'	13° 52'	11° 18'	9° 32'	7° 2'	5° 42'	4° 48'	4° 8'	3° 14'	2° 40'
CM090	Z		4	3	2	2	2	1	1	1	1	1	1
	β		29° 11'	22° 43'	15° 36'	12° 50'	10° 53'	7° 56'	6° 30'	5° 29'	4° 45'	3° 45'	3° 6'
CM110	Z		4	3	2	2	2	1	1	1	1	1	1
	β		28° 14'	21° 56'	15° 1'	14° 41'	12° 34'	7° 38'	7° 28'	6° 21'	5° 32'	4° 24'	3° 39'
CM130	Z		4	3	2	2	2	1	1	1	1	1	1
	β		28° 43'	22° 20'	15° 19'	13° 47'	11° 54'	7° 48'	7° 00'	6° 01'	5° 16'	4° 08'	3° 27'
CM150	Z		6	4	3	2	2	2	1	1	1	1	1
	β		32° 09'	24° 35'	17° 27'	12° 53'	11° 19'	9° 50'	6° 32'	5° 43'	4° 57'	3° 55'	3° 14'

Rendimiento

Rendimento

Efficiency

	n ₁ [min ⁻¹]	Rendimiento Rendimento Efficiency	Relación de reducción / Relação / Ratio											
			5	7.5	10	15	20	25	30	40	50	60	80	100
CM026	2800	Rd	89	87	85	83	80		73	68	64	60		
	1400		87	84	83	78	74		66	61	57	53		
	900		84	83	80	75	71		61	57	52	48		
CM030	2800	Rs	72	71	68	61	56	46	41	36	34			
	1400		89	88	86	84	81	78	74	70	65	62	57	52
	900		84	83	81	75	71	68	62	58	53	49	43	39
CM040	2800	Rs	72	67	63	55	50	43	39	35	31	27	23	21
	1400		90	89	87	84	83	80	77	73	69	66	60	56
	900		88	86	84	81	78	74	70	65	60	58	52	46
CM050	2800	Rs	74	71	67	60	55	51	45	40	36	32	28	24
	1400		91	90	88	86	84	82	78	74	71	68	62	58
	900		89	87	85	82	79	76	72	67	63	60	54	49
CM063	2800	Rs	87	85	84	79	75	72	68	62	59	55	48	43
	1400		91	90	88	86	84	83	79	76	73	70	65	60
	900		89	88	86	84	81	78	75	70	65	61	58	52
CM070	2800	Rs	73	71	67	60	55	51	45	40	36	33	28	24
	1400		90	89	87	85	84	80	77	74	72	67	62	
	900		89	87	84	82	80	76	72	67	63	60	54	49
CM075	2800	Rs	72	69	62	60	55	48	43	38	36	31	26	
	1400		90	89	87	85	84	81	78	75	72	68	63	
	900		89	87	84	83	80	77	73	68	64	61	55	50
CM090	2800	Rs	73	69	62	59	55	48	43	39	36	31	27	
	1400		91	90	88	86	85	83	80	78	75	71	67	
	900		88	87	84	82	80	76	72	68	65	60	55	
CM110	2800	Rs	74	71	65	61	59	51	46	42	39	34	30	
	1400		90	89	88	86	85	84	80	79	76	73	68	
	900		88	87	84	83	82	78	75	71	68	63	59	
CM130	2800	Rs	74	71	64	64	60	50	49	46	42	37	33	
	1400		90	89	88	87	86	82	80	79	77	72	70	
	900		89	88	86	84	83	79	76	75	73	69	64	
CM150	2800	Rs	74	71	64	64	60	50	49	46	42	37	33	
	1400		92	91	90	89	87	86	83	80	78	73	72	
	900		91	90	88	86	84	83	78	76	73	68	64	
CM150	2800	Rs	90	89	87	84	83	81	75	74	71	64	60	
	1400		91	90	88	86	84	83	78	76	73	68	64	
	900		90	89	87	84	83	81	75	74	71	64	60	



Rendimiento teórico del reductor después del rodaje

Rendimento teórico do redutor após a rodagem

Theoretical efficiency of the gearbox after the first running period

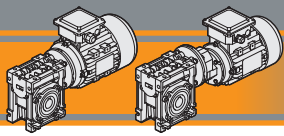

Datos técnicos

Dados técnicos

Technical data

n_1 1750 [min⁻¹]

	n_2 [min ⁻¹]	Mn_2 [Nm]	Pn_1 [kW]	i
CMIS026				
	350	13	0.55	5
	233	14	0.41	7.5
	175	14	0.31	10
	117	14	0.22	15
	88	14	0.17	20
	58	15	0.14	30
	44	14	0.11	40
	35	13	0.08	50
	29	12	0.07	60

CMIS030				
	350	18	0.77	5
	233	20	0.57	7.5
	175	21	0.46	10
	117	21	0.32	15
	88	19	0.23	20
	70	20	0.20	25
	58	22	0.20	30
	44	20	0.15	40
	35	19	0.12	50
	29	17	0.09	60
	22	15	0.07	80
	18	14	0.06	100

CMIS040				
	350	41	1.7	5
	233	44	1.3	7.5
	175	45	0.98	10
	117	45	0.68	15
	88	40	0.47	20
	70	38	0.38	25
	58	48	0.42	30
	44	42	0.30	40
	35	39	0.24	50
	29	36	0.19	60
	22	33	0.15	80
	18	31	0.12	100

CMIS050				
	350	75	3.1	5
	233	79	2.2	7.5
	175	82	1.8	10
	117	82	1.2	15
	88	72	0.84	20
	70	70	0.68	25
	58	88	0.75	30
	44	76	0.52	40
	35	72	0.42	50
	29	69	0.35	60
	22	60	0.25	80
	18	56	0.21	100

CMIS063				
	350	134	5.5	5
	233	144	4.0	7.5
	175	148	3.2	10
	117	154	2.2	15
	88	136	1.5	20
	70	135	1.3	25
	58	166	1.4	30
	44	142	0.93	40
	35	136	0.76	50
	29	126	0.61	60
	22	118	0.47	80
	18	116	0.41	100

	n_2 [min ⁻¹]	Mn_2 [Nm]	Pn_1 [kW]	i
CMIS070				
	233	200	5.5	7.5
	175	218	4.6	10
	117	221	3.2	15
	88	202	2.3	20
	70	180	1.6	25
	58	241	1.9	30
	44	210	1.3	40
	35	190	1.0	50
	29	181	0.85	60
	22	159	0.61	80
	18	154	0.53	100

CMIS075				
	233	238	6.5	7.5
	175	257	5.4	10
	117	266	3.9	15
	88	242	2.7	20
	70	225	2.1	25
	58	289	2.3	30
	44	251	1.6	40
	35	227	1.2	50
	29	218	1.0	60
	22	193	0.74	80
	18	183	0.61	100

CMIS090				
	233	342	9.3	7.5
	175	380	7.8	10
	117	433	6.2	15
	88	414	4.5	20
	70	369	3.3	25
	58	493	3.8	30
	44	434	2.6	40
	35	385	1.9	50
	29	352	1.5	60
	22	324	1.2	80
	18	299	0.91	100

CMIS110				
	233	605	16.4	7.5
	175	669	13.8	10
	117	730	10.3	15
	88	740	8.0	20
	70	670	5.8	25
	58	815	6.1	30
	44	768	4.5	40
	35	699	3.4	50
	29	626	2.6	60
	22	562	1.9	80
	18	523	1.5	100

CMIS130				
	233	750	20.6	7.5
	175	820	17.1	10
	117	910	12.9	15
	88	910	9.9	20
	70	920	8.1	25
	58	1050	8.1	30
	44	1050	6.3	40
	35	970	4.7	50
	29	890	3.7	60
	22	830	2.8	80
	18	735	2.1	100

CMIS150				
	233	1080	29.0	7.5
	175	1116	22.7	10
	117	1125	15.6	15
	88	1170	12.5	20
	70	1080	9.4	25
	58	1080	7.9	30
	44	1395	8.2	40
	35	1260	6.1	50
	29	1134	4.7	60
	22	1035	3.5	80
	18	900	2.6	100

Nota: Pn_1 es la potencia mecánica de entrada que será reducida por el factor de calentamiento con el fin de obtener el correspondiente. Para más información, favor de ponerse en contacto con nuestro servicio técnico.

Nota: Pn_1 é a potência mecânica. A potência aplicável é reduzida do fator térmico. Para maiores detalhes, consulte nosso Serviço Técnico.



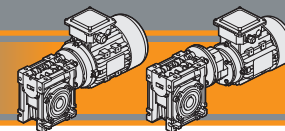



Note: Pn_1 is an input mechanical power which must be reduced by the heating factor in order to get the relevant one. For more details please contact our Technical Service.



Datos técnicos

Dados técnicos

Technical data

P_1 [kW]	n_2 [min ⁻¹]	M_2 [Nm]	sf	i				P_1 [kW]	n_2 [min ⁻¹]	M_2 [Nm]	sf	i			
---------------	-------------------------------	---------------	----	---	---	---	---	---------------	-------------------------------	---------------	----	---	---	---	---

0.09

(0.12 hp)	350	2	6.1	5	CM026		B14	
	233	3	4.5	7.5	CM026		B14	
	56B4 (1750 min ⁻¹)	175	4	3.4	10	CM026		B14
		117	6	2.4	15	CM026		B14
		88	7	1.9	20	CM026		B14
		58	10	1.5	30	CM026		B14
		44	12	1.2	40	CM026		B14
		35	14	0.9	50	CM026		B14
		29	16	0.8	60	CM026		B14
		88	7	2.6	20	CM030		B5/B14
	70	9	2.3	25	CM030		B5/B14	
	58	10	2.2	30	CM030		B5/B14	
44	12	1.6	40	CM030		B5/B14		
35	14	1.3	50	CM030		B5/B14		
29	16	1.0	60	CM030		B5/B14		
29	19	1.3	60		CMP056/030	B14		
23	23	1.2	75		CMP056/030	B14		
22	19	0.8	80	CM030		B5/B14		
19	26	1.3	90		CMP056/030	B14		
18	21	0.7	100	CM030		B5/B14		
15	31	1.0	120		CMP056/030	B14		
44	13	3.3	40	CM040		B5/B14		
35	15	2.6	50	CM040		B5/B14		
29	17	2.1	60	CM040		B5/B14		
29	20	2.9	60		CMP056/040	B14		
23	24	2.1	75		CMP056/040	B14		
22	20	1.6	80	CM040		B5/B14		
19	27	2.6	90		CMP056/040	B14		
18	23	1.4	100	CM040		B5/B14		
15	33	1.9	120		CMP056/040	B14		
12	38	1.5	150		CMP056/040	B14		
10	42	1.3	180		CMP056/040	B14		
7.3	50	0.9	240		CMP056/040	B14		

0.12

(0.16 hp)	35	21	3.5	50	CM050		B5/B14	
	29	24	2.9	60	CM050		B5/B14	
	63A4 (1750 min ⁻¹)	29	27	3.8	60		CMP063/050	B14
		23	32	2.9	75		CMP063/050	B14
		22	28	2.1	80	CM050		B5/B14
		19	38	3.4	90		CMP063/050	B14
		18	32	1.7	100	CM050		B5/B14
		15	45	2.4	120		CMP063/050	B14
		12	53	2.0	150		CMP063/050	B14
		10	59	1.6	180		CMP063/050	B14
		7.3	68	1.3	240		CMP063/050	B14
22		30	4.0	80	CM063		B5	
19	37	6.4	90		CMP063/063	B14		
18	34	3.4	100	CM063		B5		
15	46	4.5	120		CMP063/063	B14		
12	55	3.5	150		CMP063/063	B14		
10	61	2.9	180		CMP063/063	B14		
7.3	72	2.1	240		CMP063/063	B14		
5.8	81	1.7	300		CMP063/063	B14		

0.18

(0.25 hp)	350	4	4.3	5	CM030		B5/B14	
	233	6	3.2	7.5	CM030		B5/B14	
	63B4 (1750 min ⁻¹)	175	8	2.5	10	CM030		B5/B14
		117	12	1.8	15	CM030		B5/B14
		88	15	1.3	20	CM030		B5/B14
		70	18	1.1	25	CM030		B5/B14
		58	20	1.1	30	CM030		B5/B14
		44	24	0.8	40	CM030		B5/B14
		117	12	3.8	15	CM040		B5/B14
		88	15	2.6	20	CM040		B5/B14
		70	18	2.1	25	CM040		B5/B14
		58	21	2.3	30	CM040		B5/B14
		44	26	1.6	40	CM040		B5/B14
35		29	1.3	50	CM040		B5/B14	
29	34	1.1	60	CM040		B5/B14		
29	40	1.4	60		CMP063/040	B14		
23	48	1.1	75		CMP063/040	B14		
19	55	1.3	90		CMP063/040	B14		
15	67	0.9	120		CMP063/040	B14		
44	26	2.9	40	CM050		B5/B14		
35	31	2.3	50	CM050		B5/B14		
29	35	2.0	60	CM050		B5/B14		
29	41	2.5	60		CMP063/050	B14		
23	48	1.9	75		CMP063/050	B14		
22	42	1.4	80	CM050		B5/B14		
19	56	2.2	90		CMP063/050	B14		
18	48	1.2	100	CM050		B5/B14		
15	68	1.6	120		CMP063/050	B14		
12	79	1.3	150		CMP063/050	B14		
10	88	1.1	180		CMP063/050	B14		

0.12



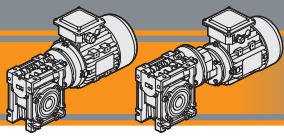



(0.16 hp)	350	3	6.4	5	CM030		B5/B14	
	233	4	4.8	7.5	CM030		B5/B14	
	63A4 (1750 min ⁻¹)	175	6	3.8	10	CM030		B5/B14
		117	8	2.7	15	CM030		B5/B14
		88	10	1.9	20	CM030		B5/B14
		70	12	1.7	25	CM030		B5/B14
		58	13	1.7	30	CM030		B5/B14
		44	16	1.2	40	CM030		B5/B14
		35	19	1.0	50	CM030		B5/B14
		88	10	3.9	20	CM040		B5/B14
		70	12	3.1	25	CM040		B5/B14
		58	14	3.5	30	CM040		B5/B14
		44	17	2.5	40	CM040		B5/B14
		35	20	2.0	50	CM040		B5/B14
29		23	1.6	60	CM040		B5/B14	
29	27	2.2	60		CMP063/040	B14		
23	32	1.6	75		CMP063/040	B14		
22	27	1.2	80	CM040		B5/B14		
19	36	2.0	90		CMP063/040	B14		
18	30	1.0	100	CM040		B5/B14		
15	45	1.4	120		CMP063/040	B14		



Datos técnicos

Dados técnicos

Technical data



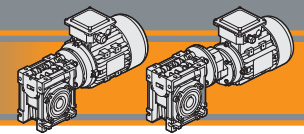



P_1 [kW]	n_2 [min ⁻¹]	M_2 [Nm]	sf	i				P_1 [kW]	n_2 [min ⁻¹]	M_2 [Nm]	sf	i			
0.18								0.37							
(0.25 hp)	29	37	3.4	60	CM063		B5	(0.50 hp)	350	9	4.6	5	CM040		B5/B14
	29	42	4.5	60		CMP063/063	B14		233	13	3.4	7.5	CM040		B5/B14
63B4	23	51	3.4	75		CMP063/063	B14	71A4	175	17	2.7	10	CM040		B5/B14
(1750 min ⁻¹)	22	45	2.6	80	CM063		B5	(1750 min ⁻¹)	117	25	1.8	15	CM040		B5/B14
	19	55	4.2	90		CMP063/063	B14		88	31	1.3	20	CM040		B5/B14
	18	51	2.3	100	CM063		B5		70	37	1.0	25	CM040		B5/B14
	15	69	3.0	120		CMP063/063	B14		58	42	1.1	30	CM040		B5/B14
	12	82	2.3	150		CMP063/063	B14		44	52	0.8	40	CM040		B5/B14
	10	92	1.9	180		CMP063/063	B14								
	7	109	1.4	240		CMP063/063	B14		117	25	3.3	15	CM050		B5/B14
	6	121	1.2	300		CMP063/063	B14		88	32	2.3	20	CM050		B5/B14
									70	38	1.8	25	CM050		B5/B14
									58	44	2.0	30	CM050		B5/B14
									44	54	1.4	40	CM050		B5/B14
									35	64	1.1	50	CM050		B5/B14
									29	73	0.9	60	CM050		B5/B14
									29	84	1.2	60		CMP071/050	B14
									23	99	0.9	75		CMP071/050	B14
									19	116	1.1	90		CMP071/050	B14
	175	11	3.9	10	CM040		B5/B14		70	39	3.4	25	CM063		B5/B14
	117	17	2.7	15	CM040		B5/B14		58	45	3.7	30	CM063		B5/B14
	88	21	1.9	20	CM040		B5/B14		44	57	2.5	40	CM063		B5/B14
	70	25	1.5	25	CM040		B5/B14		35	67	2.0	50	CM063		B5/B14
	58	29	1.7	30	CM040		B5/B14		29	76	1.7	60	CM063		B5/B14
	44	35	1.2	40	CM040		B5/B14		29	87	2.2	60		CMP071/063	B14
	35	41	1.0	50	CM040		B5/B14		23	104	1.7	75		CMP071/063	B14
	29	56	1.0	60		CMP063/040	B14		22	92	1.3	80	CM063		B5/B14
	23	66	0.8	75		CMP063/040	B14		19	114	2.1	90		CMP071/063	B14
	19	76	0.9	90		CMP063/040	B14		18	105	1.1	100	CM063		B5/B14
									15	142	1.4	120		CMP071/063	B14
	88	22	3.3	20	CM050		B5/B14		12	169	1.1	150		CMP071/063	B14
	70	26	2.7	25	CM050		B5/B14		10	189	0.9	180		CMP071/063	B14
	58	29	3.0	30	CM050		B5/B14								
	44	37	2.1	40	CM050		B5/B14		35	69	2.8	50	CM070		B5
	35	43	1.7	50	CM050		B5/B14		29	79	2.3	60	CM070		B5
	29	49	1.4	60	CM050		B5/B14		29	88	3.2	60		CMP071/070	B14
	29	57	1.8	60		CMP063/050	B14		23	105	2.4	75		CMP071/070	B14
	23	67	1.4	75		CMP063/050	B14		22	97	1.6	80	CM070		B5
	22	59	1.0	80	CM050		B5/B14		19	118	2.9	90		CMP071/070	B14
	19	78	1.6	90		CMP063/050	B14		18	107	1.4	100	CM070		B5
	15	95	1.2	120		CMP063/050	B14		15	145	2.1	120		CMP071/070	B14
	12	110	0.9	150		CMP063/050	B14		12	169	1.6	150		CMP071/070	B14
									10	189	1.4	180		CMP071/070	B14
									7	223	1.0	240		CMP071/070	B14
	44	38	3.7	40	CM063		B5		22	97	2.0	80	CM075		B5
	35	45	3.0	50	CM063		B5		19	119	3.4	90		CMP071/075	B14
	29	52	2.4	60	CM063		B5		18	111	1.6	100	CM075		B5
	29	59	3.2	60		CMP063/063	B14		15	147	2.5	120		CMP071/075	B14
	23	70	2.5	75		CMP063/063	B14		12	172	1.9	150		CMP071/075	B14
	22	62	1.9	80	CM063		B5		10	192	1.6	180		CMP071/075	B14
	19	77	3.1	90		CMP063/063	B14		7	228	1.2	240		CMP071/075	B14
	18	71	1.6	100	CM063		B5		6	255	0.9	300		CMP071/075	B14
	15	96	2.1	120		CMP063/063	B14								
	12	114	1.7	150		CMP063/063	B14								
	10	128	1.4	180		CMP063/063	B14								
	7	151	1.0	240		CMP063/063	B14								



Datos técnicos

Dados técnicos

Technical data

P_1 [kW]	n_2 [min ⁻¹]	M_2 [Nm]	sf	i				P_1 [kW]	n_2 [min ⁻¹]	M_2 [Nm]	sf	i			
0.37								0.55							
(0.50 hp)	22	103	3.1	80	CM090		B5	(0.75 hp)	23	165	3.1	75		CMP071/090	B14
	19	125	5.5	90		CMP071/090	B14		22	154	2.1	80	CM090		B5
71A4	18	121	2.5	100	CM090		B5	71B4	19	185	3.7	90		CMP071/090	B14
(1750 min ⁻¹)	15	154	4.0	120		CMP071/090	B14	(1750 min ⁻¹)	18	180	1.7	100	CM090		B5
	12	181	3.1	150		CMP071/090	B14		15	229	2.7	120		CMP071/090	B14
	10	210	2.4	180		CMP071/090	B14		12	269	2.1	150		CMP071/090	B14
	7	247	1.8	240		CMP071/090	B14		10	312	1.6	180		CMP071/090	B14
	6	279	1.5	300		CMP071/090	B14		7	367	1.2	240		CMP071/090	B14
	6	279	1.5	300		CMP071/090	B14		6	415	1.0	300		CMP071/090	B14
0.55								0.75							
(0.75 hp)	350	13	3.1	5	CM040		B5/B14	(1.0 hp)	350	18	4.1	5	CM050		B5/B14
	233	19	2.3	7.5	CM040		B5/B14		233	27	3.0	7.5	CM050		B5/B14
71B4	175	25	1.8	10	CM040		B5/B14	80A4	175	35	2.4	10	CM050		B5/B14
(1750 min ⁻¹)	117	36	1.2	15	CM040		B5/B14	(1750 min ⁻¹)	117	50	1.6	15	CM050		B5/B14
	88	47	0.9	20	CM040		B5/B14		88	65	1.1	20	CM050		B5/B14
	350	13	5.6	5	CM050		B5/B14		70	78	0.9	25	CM050		B5/B14
	233	20	4.0	7.5	CM050		B5/B14		58	88	1.0	30	CM050		B5/B14
	175	26	3.2	10	CM050		B5/B14		117	52	3.0	15	CM063		B5/B14
	117	37	2.2	15	CM050		B5/B14		88	66	2.1	20	CM063		B5/B14
	88	47	1.5	20	CM050		B5/B14		70	80	1.7	25	CM063		B5/B14
	70	57	1.2	25	CM050		B5/B14		58	92	1.8	30	CM063		B5/B14
	58	65	1.4	30	CM050		B5/B14		44	115	1.2	40	CM063		B5/B14
	44	80	0.9	40	CM050		B5/B14		35	135	1.0	50	CM063		B5/B14
	117	38	4.1	15	CM063		B5/B14		29	155	0.8	60	CM063		B5/B14
	88	49	2.8	20	CM063		B5/B14		29	176	1.1	60		CMP080/063	B14
	70	59	2.3	25	CM063		B5/B14		19	231	1.0	90		CMP080/063	B14
	58	68	2.5	30	CM063		B5/B14		88	67	3.0	20	CM070		B5/B14
	44	84	1.7	40	CM063		B5/B14		70	82	2.2	25	CM070		B5/B14
	35	99	1.4	50	CM063		B5/B14		58	93	2.6	30	CM070		B5/B14
	29	113	1.1	60	CM063		B5/B14		44	118	1.8	40	CM070		B5/B14
	29	129	1.5	60		CMP071/063	B14		35	139	1.4	50	CM070		B5/B14
	23	154	1.1	75		CMP071/063	B14		29	160	1.1	60	CM070		B5/B14
	22	137	0.9	80	CM063		B5/B14		29	178	1.6	60		CMP080/070	B14
	19	169	1.4	90		CMP071/063	B14		23	214	1.2	75		CMP080/070	B14
	15	212	1.0	120		CMP071/063	B14		19	238	1.4	90		CMP080/070	B14
	35	102	1.9	50	CM070		B5		15	294	1.0	120		CMP080/070	B14
	29	117	1.5	60	CM070		B5		44	118	2.1	40	CM075		B5/B14
	29	131	2.2	60		CMP071/070	B14		35	141	1.6	50	CM075		B5/B14
	23	157	1.6	75		CMP071/070	B14		29	160	1.4	60	CM075		B5/B14
	22	144	1.1	80	CM070		B5		29	180	1.9	60		CMP080/075	B14
	19	175	2.0	90		CMP071/070	B14		23	217	1.4	75		CMP080/075	B14
	18	159	1.0	100	CM070		B5		22	196	1.0	80	CM075		B5/B14
	15	215	1.4	120		CMP071/070	B14		19	242	1.7	90		CMP080/075	B14
	12	251	1.1	150		CMP071/070	B14		15	298	1.2	120		CMP080/075	B14
	10	281	0.9	180		CMP071/070	B14		12	349	0.9	150		CMP080/075	B14
	29	132	2.5	60		CMP071/075	B14		35	149	2.6	50	CM090		B5/B14
	23	159	1.9	75		CMP071/075	B14		29	172	2.0	60	CM090		B5/B14
	22	144	1.3	80	CM075		B5		29	188	3.1	60		CMP080/090	B14
	19	177	2.3	90		CMP071/075	B14		23	226	2.3	75		CMP080/090	B14
	18	165	1.1	100	CM075		B5		22	210	1.5	80	CM090		B5/B14
	15	219	1.7	120		CMP071/075	B14		19	253	2.7	90		CMP080/090	B14
	12	256	1.3	150		CMP071/075	B14		18	246	1.2	100	CM090		B5/B14
	10	286	1.1	180		CMP071/075	B14		15	313	2.0	120		CMP080/090	B14
									12	367	1.5	150		CMP080/090	B14
									10	426	1.2	180		CMP080/090	B14



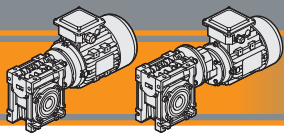



CM/CMP



Datos técnicos

Dados técnicos

Technical data

P ₁ [kW]	n ₂ [min ⁻¹]	M ₂ [Nm]	sf	i				P ₁ [kW]	n ₂ [min ⁻¹]	M ₂ [Nm]	sf	i			
0.75								1.1							
(1.0 hp)	29	179	3.5	60	CM110		B5	(1.5 hp)	70	125	3.0	25	CM090		B5/B14
	29	193	5.0	60		CMP080/110	B14		58	144	3.4	30	CM090		B5/B14
80A4	23	235	3.9	75		CMP080/110	B14	80B4	44	182	2.4	40	CM090		B5/B14
(1750 min ⁻¹)	22	223	2.5	80	CM110		B5	(1750 min ⁻¹)	35	219	1.8	50	CM090		B5/B14
	19	260	4.4	90		CMP080/110	B14		29	252	1.4	60	CM090		B5/B14
	18	262	2.0	100	CM110		B5		29	275	2.1	60		CMP080/090	B14
	15	332	3.3	120		CMP080/110	B14		23	331	1.5	75		CMP080/090	B14
	12	391	2.5	150		CMP080/110	B14		22	307	1.1	80	CM090		B5/B14
	10	448	2.0	180		CMP080/110	B14		19	371	1.9	90		CMP080/090	B14
	7	549	1.4	240		CMP080/110	B14		15	459	1.4	120		CMP080/090	B14
	6	626	1.1	300		CMP080/110	B14		12	538	1.0	150		CMP080/090	B14
	22	226	3.7	80	CM130		B5		35	228	3.1	50	CM110		B5
	19	260	5.4	90		CMP080/130	B14		29	263	2.4	60	CM110		B5
	18	262	2.8	100	CM130		B5		29	282	3.4	60		CMP080/110	B14
	15	327	3.8	120		CMP080/130	B14		23	344	2.6	75		CMP080/110	B14
	12	403	3.1	150		CMP080/130	B14		22	327	1.7	80	CM110		B5
	10	462	2.3	180		CMP080/130	B14		19	381	3.0	90		CMP080/110	B14
	7	558	1.8	240		CMP080/130	B14		18	384	1.4	100	CM110		B5
	6	638	1.3	300		CMP080/130	B14		15	487	2.2	120		CMP080/110	B14
									12	574	1.7	150		CMP080/110	B14
									10	657	1.3	180		CMP080/110	B14
									7	805	1.0	240		CMP080/110	B14
1.1								1.5							
(1.5 hp)	350	27	2.8	5	CM050		B5/B14	(2.0 hp)	350	37	3.6	5	CM063		B5/B14
	233	39	2.0	7.5	CM050		B5/B14		233	54	2.7	7.5	CM063		B5/B14
80B4	175	51	1.6	10	CM050		B5/B14	90S4	175	70	2.1	10	CM063		B5/B14
(1750 min ⁻¹)	117	74	1.1	15	CM050		B5/B14	(1750 min ⁻¹)	117	103	1.5	15	CM063		B5/B14
	350	27	5.0	5	CM063		B5/B14		88	133	1.0	20	CM063		B5/B14
	233	40	3.6	7.5	CM063		B5/B14		70	160	0.8	25	CM063		B5/B14
	175	52	2.9	10	CM063		B5/B14		58	184	0.9	30	CM063		B5/B14
	117	76	2.0	15	CM063		B5/B14								
	88	97	1.4	20	CM063		B5/B14		233	55	3.7	7.5	CM070		B5/B14
	70	117	1.2	25	CM063		B5/B14		175	71	3.1	10	CM070		B5/B14
	58	135	1.2	30	CM063		B5/B14		117	103	2.1	15	CM070		B5/B14
									88	134	1.5	20	CM070		B5/B14
	117	76	2.9	15	CM070		B5/B14		70	164	1.1	25	CM070		B5/B14
	88	98	2.1	20	CM070		B5/B14		58	187	1.3	30	CM070		B5/B14
	70	120	1.5	25	CM070		B5/B14		44	236	0.9	40	CM070		B5/B14
	58	137	1.8	30	CM070		B5/B14								
	44	173	1.2	40	CM070		B5/B14		117	103	2.6	15	CM075		B5/B14
	35	204	0.9	50	CM070		B5/B14		88	136	1.8	20	CM075		B5/B14
	29	261	1.1	60		CMP080/070	B14		70	164	1.4	25	CM075		B5/B14
	23	313	0.8	75		CMP080/070	B14		58	189	1.5	30	CM075		B5/B14
	19	349	1.0	90		CMP080/070	B14		44	236	1.1	40	CM075		B5/B14
									29	361	0.9	60	CM075		B5/B14
	88	100	2.4	20	CM075		B5/B14								
	70	120	1.9	25	CM075		B5/B14								
	58	139	2.1	30	CM075		B5/B14								
	44	173	1.5	40	CM075		B5/B14								
	35	207	1.1	50	CM075		B5/B14								
	29	234	0.9	60	CM075		B5/B14								
	29	265	1.3	60		CMP080/075	B14								
	23	318	0.9	75		CMP080/075	B14								
	19	355	1.1	90		CMP080/075	B14								

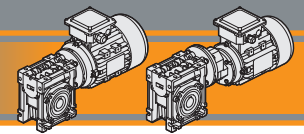

Datos técnicos

Dados técnicos

Technical data

P_1 [kW]	n_2 [min ⁻¹]	M_2 [Nm]	sf	i				P_1 [kW]	n_2 [min ⁻¹]	M_2 [Nm]	sf	i			
1.5								2.2							
(2.0 hp)	88	138	3.0	20	CM090		B5/B14	(3.0 hp)	117	155	2.8	15	CM090		B5/B14
	70	170	2.2	25	CM090		B5/B14		88	202	2.1	20	CM090		B5/B14
90S4	58	196	2.5	30	CM090		B5/B14	90L4	70	249	1.5	25	CM090		B5/B14
(1750 min ⁻¹)	44	249	1.7	40	CM090		B5/B14	(1750 min ⁻¹)	58	288	1.7	30	CM090		B5/B14
	35	299	1.3	50	CM090		B5/B14		44	365	1.2	40	CM090		B5/B14
	29	344	1.0	60	CM090		B5/B14		35	438	0.9	50	CM090		B5/B14
	29	375	1.5	60		CMP090/090	B5/B14		29	551	1.0	60		CMP090/090	B5/B14
	23	451	1.1	75		CMP090/090	B5/B14								
	19	505	1.4	90		CMP090/090	B5/B14		88	204	3.6	20	CM110		B5/B14
	15	626	1.0	120		CMP090/090	B5/B14		70	252	2.7	25	CM110		B5/B14
									58	292	2.8	30	CM110		B5/B14
	44	259	3.0	40	CM110		B5/B14		44	379	2.0	40	CM110		B5/B14
	35	311	2.2	50	CM110		B5/B14		35	456	1.5	50	CM110		B5/B14
	29	359	1.7	60	CM110		B5/B14		29	526	1.2	60	CM110		B5/B14
	29	385	2.5	60		CMP090/110	B5/B14		29	565	1.7	60		CMP090/110	B5/B14
	23	469	1.9	75		CMP090/110	B5/B14		23	688	1.3	75		CMP090/110	B5/B14
	22	445	1.3	80	CM110		B5/B14		22	653	0.9	80	CM110		B5/B14
	19	520	2.2	90		CMP090/110	B5/B14		19	762	1.5	90		CMP090/110	B5/B14
	18	524	1.0	100	CM110		B5/B14		15	974	1.1	120		CMP090/110	B5/B14
	15	664	1.6	120		CMP090/110	B5/B14		12	1147	0.9	150		CMP090/110	B5/B14
	12	782	1.3	150		CMP090/110	B5/B14								
	10	895	1.0	180		CMP090/110	B5/B14		44	365	2.9	40	CM130		B5
									35	450	2.2	50	CM130		B5
	35	307	3.2	50	CM130		B5		29	526	1.7	60	CM130		B5
	29	359	2.5	60	CM130		B5		29	558	2.2	60		CMP090/130	B5/B14
	29	380	3.3	60		CMP090/130	B5/B14		23	679	1.8	75		CMP090/130	B5/B14
	23	463	2.6	75		CMP090/130	B5/B14		22	663	1.3	80	CM130		B5
	22	452	1.8	80	CM130		B5		19	762	1.8	90		CMP090/130	B5/B14
	19	520	2.7	90		CMP090/130	B5/B14		18	768	1.0	100	CM130		B5
	18	524	1.4	100	CM130		B5		15	960	1.3	120		CMP090/130	B5/B14
	15	655	1.9	120		CMP090/130	B5/B14		12	1182	1.0	150		CMP090/130	B5/B14
	12	806	1.5	150		CMP090/130	B5/B14								
	10	924	1.2	180		CMP090/130	B5/B14								
	7	1117	0.9	240		CMP090/130	B5/B14								
2.2								3.0							
(3.0 hp)	350	54	2.5	5	CM063		B5/B14	(4.0 hp)	233	109	1.8	7.5	CM070		B5/B14
	233	79	1.8	7.5	CM063		B5/B14		175	142	1.5	10	CM070		B5/B14
90L4	175	103	1.4	10	CM063		B5/B14	100LA4	117	206	1.1	15	CM070		B5/B14
(1750 min ⁻¹)	117	151	1.0	15	CM063		B5/B14	(1750 min ⁻¹)							
									233	109	2.2	7.5	CM075		B5/B14
	233	80	2.5	7.5	CM070		B5/B14		175	142	1.8	10	CM075		B5/B14
	175	104	2.1	10	CM070		B5/B14		117	206	1.3	15	CM075		B5/B14
	117	151	1.5	15	CM070		B5/B14		88	272	0.9	20	CM075		B5/B14
	88	197	1.0	20	CM070		B5/B14								
	58	274	0.9	30	CM070		B5/B14		233	111	3.1	7.5	CM090		B5/B14
									175	146	2.6	10	CM090		B5/B14
	233	80	3.0	7.5	CM075		B5/B14		117	211	2.1	15	CM090		B5/B14
	175	104	2.5	10	CM075		B5/B14		88	275	1.5	20	CM090		B5/B14
	117	151	1.8	15	CM075		B5/B14		70	340	1.1	25	CM090		B5/B14
	88	199	1.2	20	CM075		B5/B14		58	393	1.3	30	CM090		B5/B14
	70	240	0.9	25	CM075		B5/B14		44	498	0.9	40	CM090		B5/B14
	58	277	1.0	30	CM075		B5/B14								
									117	214	3.4	15	CM110		B5/B14
									88	278	2.7	20	CM110		B5/B14
									70	344	1.9	25	CM110		B5/B14



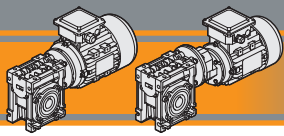



CM/CMP







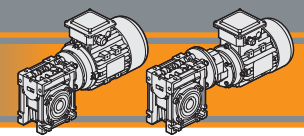

Datos técnicos

Dados técnicos

Technical data

P_1 [kW]	n_2 [min ⁻¹]	M_2 [Nm]	sf	i				P_1 [kW]	n_2 [min ⁻¹]	M_2 [Nm]	sf	i					
3.0								4.5									
(4.0 hp) 100LA4 (1750 min ⁻¹)	58	398	2.0	30	CM110		B5/B14	(6.0 hp) 112MA4 (1750 min ⁻¹)	233	164	1.2	7.5	CM070		B5/B14		
	44	517	1.5	40	CM110		B5/B14		175	214	1.0	10	CM070		B5/B14		
	35	622	1.1	50	CM110		B5/B14		233	164	1.5	7.5	CM075		B5/B14		
	29	717	0.9	60	CM110		B5/B14		175	214	1.2	10	CM075		B5/B14		
	70	340	2.7	25	CM130		B5		117	309	0.9	15	CM075		B5/B14		
	58	388	2.7	30	CM130		B5		233	166	2.1	7.5	CM090		B5/B14		
	44	498	2.1	40	CM130		B5		175	219	1.7	10	CM090		B5/B14		
	35	614	1.6	50	CM130		B5		117	317	1.4	15	CM090		B5/B14		
	29	717	1.2	60	CM130		B5		88	413	1.0	20	CM090		B5/B14		
	22	904	0.9	80	CM130		B5		233	166	3.6	7.5	CM110		B5/B14		
	44	511	2.7	40	CM150		B5		175	219	3.1	10	CM110		B5/B14		
	35	622	2.0	50	CM150		B5		117	320	2.3	15	CM110		B5/B14		
	29	717	1.6	60	CM150		B5		88	417	1.8	20	CM110		B5/B14		
	22	891	1.2	80	CM150		B5		70	516	1.3	25	CM110		B5/B14		
	18	1048	0.9	100	CM150		B5		58	597	1.4	30	CM110		B5/B14		
	44	511	2.7	40	CM150		B5		44	776	1.0	40	CM110		B5/B14		
	3.7								5.5								
	(5.0 hp) 100LB4 (1750 min ⁻¹)	233	135	1.5	7.5	CM070			B5/B14	(7.5 hp) 112MB4 (1750 min ⁻¹)	233	164	4.6	7.5	CM130		B5
175		176	1.2	10	CM070		B5/B14	175	216		3.8	10	CM130		B5		
233		135	1.8	7.5	CM075		B5/B14	117	317		2.9	15	CM130		B5		
175		176	1.5	10	CM075		B5/B14	88	413		2.2	20	CM130		B5		
117		254	1.0	15	CM075		B5/B14	70	510		1.8	25	CM130		B5		
233		136	2.5	7.5	CM090		B5/B14	58	582		1.8	30	CM130		B5		
175		180	2.1	10	CM090		B5/B14	44	747		1.4	40	CM130		B5		
117		260	1.7	15	CM090		B5/B14	35	921		1.1	50	CM130		B5		
88		339	1.2	20	CM090		B5/B14	88	422		2.8	20	CM150		B5		
70		419	0.9	25	CM090		B5/B14	70	516		2.1	25	CM150		B5		
58		485	1.0	30	CM090		B5/B14	58	611		1.8	30	CM150		B5		
233		136	4.4	7.5	CM110		B5/B14	44	766		1.8	40	CM150		B5		
175		180	3.7	10	CM110		B5/B14	35	933		1.4	50	CM150		B5		
117		263	2.8	15	CM110		B5/B14	29	1076		1.1	60	CM150		B5		
88		343	2.2	20	CM110		B5/B14	233	200		1.0	7.5	CM070		B5/B14		
70		424	1.6	25	CM110		B5/B14	112MB4	233		200	1.2	7.5	CM075		B5/B14	
58		491	1.7	30	CM110		B5/B14	(1750 min ⁻¹)	175		261	1.0	10	CM075		B5/B14	
44		638	1.2	40	CM110		B5/B14	233	203		1.7	7.5	CM090		B5/B14		
35		767	0.9	50	CM110		B5/B14	175	267		1.4	10	CM090		B5/B14		
88		339	2.7	20	CM130		B5	117	387		1.1	15	CM090		B5/B14		
70		419	2.2	25	CM130		B5	233	203		3.0	7.5	CM110		B5/B14		
58		479	2.2	30	CM130		B5	175	267		2.5	10	CM110		B5/B14		
44		614	1.7	40	CM130		B5	117	392		1.9	15	CM110		B5/B14		
35		757	1.3	50	CM130		B5	88	510		1.5	20	CM110		B5/B14		
29		884	1.0	60	CM130		B5	70	630		1.1	25	CM110		B5/B14		
70		424	2.5	25	CM150		B5	58	729		1.1	30	CM110		B5/B14		
58		503	2.1	30	CM150		B5										
44		630	2.2	40	CM150		B5										
35		767	1.6	50	CM150		B5										
29		884	1.3	60	CM150		B5										
22	1098	0.9	80	CM150		B5											

Datos técnicos
Dados técnicos
Technical data

P_1 [kW]	n_2 [min ⁻¹]	M_2 [Nm]	sf	i				P_1 [kW]	n_2 [min ⁻¹]	M_2 [Nm]	sf	i							
5.5																			
(7.5 hp)	233	200	3.7	7.5	CM130		B5	(15.0 hp)	233	405	1.5	7.5	CM110		B5/B14				
	175	264	3.1	10	CM130		B5		175	534	1.3	10	CM110		B5/B14				
112MB4 (1750 min ⁻¹)	117	387	2.4	15	CM130		B5	132L4 (1750 min ⁻¹)	117	783	0.9	15	CM110		B5/B14				
	88	504	1.8	20	CM130		B5		233	401	1.9	7.5	CM130		B5/B14				
	70	623	1.5	25	CM130		B5						CM130		B5/B14				
	58	711	1.5	30	CM130		B5						CM130		B5/B14				
	44	912	1.2	40	CM130		B5						CM130		B5/B14				
	35	1126	0.9	50	CM130		B5						CM130		B5/B14				
	117	396	2.8	15	CM150		B5						233	410	2.6	7.5	CM150		B5
	88	516	2.3	20	CM150		B5										CM150		B5
	70	630	1.7	25	CM150		B5										CM150		B5
	58	747	1.4	30	CM150		B5		CM150		B5								
44	936	1.5	40	CM150		B5	175	540	2.1	10	CM150		B5						
35	1141	1.1	50	CM150		B5	117	792	1.4	15	CM150		B5						
29	1315	0.9	60	CM150		B5	88	1032	1.1	20	CM150		B5						
							70	1261	0.9	25	CM150		B5						
7.5																			
(10.0 hp)	233	276	2.2	7.5	CM110		B5/B14	(20.0 hp)	233	559	1.9	7.5	CM150		B5				
	175	364	1.8	10	CM110		B5/B14		175	737	1.5	10	CM150		B5				
132MA4 (1750 min ⁻¹)	117	534	1.4	15	CM110		B5/B14	160M4 (1750 min ⁻¹)	117	1081	1.0	15	CM150		B5				
	88	696	1.1	20	CM110		B5/B14		233	689	1.6	7.5	CM150		B5				
	233	273	2.7	7.5	CM130		B5/B14						CM150		B5				
	175	360	2.3	10	CM130		B5/B14						CM150		B5				
	117	528	1.7	15	CM130		B5/B14						CM150		B5				
	88	688	1.3	20	CM130		B5/B14						CM150		B5				
	70	849	1.1	25	CM130		B5/B14						CM150		B5				
	58	970	1.1	30	CM130		B5/B14						CM150		B5				
	233	279	3.9	7.5	CM150		B5						233	689	1.6	7.5	CM150		B5
	175	368	3.0	10	CM150		B5		CM150		B5								
117	540	2.1	15	CM150		B5	CM150		B5										
88	704	1.7	20	CM150		B5	CM150		B5										
70	860	1.3	25	CM150		B5	175	909	1.2	10	CM150		B5						
58	1019	1.1	30	CM150		B5	117	1333	0.8	15	CM150		B5						
44	1277	1.1	40	CM150		B5													
9.2																			
(12.5 hp)	233	339	1.8	7.5	CM110		B5/B14	(25.0 hp)	233	689	1.6	7.5	CM150		B5				
	175	447	1.5	10	CM110		B5/B14		175	909	1.2	10	CM150		B5				
132MB4 (1750 min ⁻¹)	117	655	1.1	15	CM110		B5/B14	160L4 (1750 min ⁻¹)	117	1333	0.8	15	CM150		B5				
	88	853	0.9	20	CM110		B5/B14		233	689	1.6	7.5	CM150		B5				
	233	335	2.2	7.5	CM130		B5/B14						CM150		B5				
	175	442	1.9	10	CM130		B5/B14						CM150		B5				
	117	648	1.4	15	CM130		B5/B14						CM150		B5				
	88	843	1.1	20	CM130		B5/B14						CM150		B5				
	70	1042	0.9	25	CM130		B5/B14						CM150		B5				
	58	1190	0.9	30	CM130		B5/B14						CM150		B5				
	233	343	3.2	7.5	CM150		B5						233	689	1.6	7.5	CM150		B5
	175	452	2.5	10	CM150		B5		CM150		B5								
117	663	1.7	15	CM150		B5	CM150		B5										
88	864	1.4	20	CM150		B5	CM150		B5										
70	1054	1.0	25	CM150		B5	175	909	1.2	10	CM150		B5						
58	1250	0.9	30	CM150		B5	117	1333	0.8	15	CM150		B5						
44	1566	0.9	40	CM150		B5													

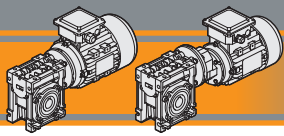

Motores aplicables

Motores aplicáveis

IEC Motor adapters

	IEC	N	M	P	D	i																	
						5	7.5	10	15	20	25	30	40	50	60	80	100						
CM026	56B14	50	65	80	9																		
CM030	63B5	95	115	140	11																		
	63B14	60	75	90																			
	56B5	80	100	120	9	B	B	B	B	B	B	B	B	B									
	56B14	50	65	80																			
CM040	71B5	110	130	160	14																		
	71B14	70	85	105																			
	63B5	95	115	140	11	B	B	B	B	B	B	B	B										
	63B14	60	75	90																			
	56B5	80	100	120	9	BS	BS	BS	BS	BS	BS	BS	BS	BS	B	B	B	B					
	56B14	50	65	80																			
CM050	80B5	130	165	200	19																		
	80B14	80	100	120																			
	71B5	110	130	160	14	B	B	B	B	B	B	B											
	71B14	70	85	105																			
	63B5	95	115	140	11	BS	BS	BS	BS	BS	BS	BS	BS	B	B	B	B						
	63B14	60	75	90																			
CM063	90B5	130	165	200	24																		
	90B14	95	115	140																			
	80B5	130	165	200	19	B	B	B	B	B	B	B											
	80B14	80	100	120																			
	71B5	110	130	160	14	BS	BS	BS	BS	BS	BS	BS	BS	B	B	B							
	71B14	70	85	105																			
	63B5	95	115	140	11									BS	BS	BS	B	B					
CM070	100/112B5	180	215	250	28																		
	100/112B14	110	130	160																			
	90B5	130	165	200	24		B	B	B	B													
	90B14	95	115	140																			
	80B5	130	165	200	19		BS	BS	BS	BS	B	B	B										
	80B14	80	100	120																			
	71B5	110	130	160	14						BS	BS	BS	B	B	B	B						
CM075	100/112B5	180	215	250	28																		
	100/112B14	110	130	160																			
	90B5	130	165	200	24		B	B	B	B	B												
	90B14	95	115	140																			
	80B5	130	165	200	19		BS	BS	BS	BS	BS	BS	B	B									
	80B14	80	100	120																			
	71B5	110	130	160	14									BS	BS	B	B	B					

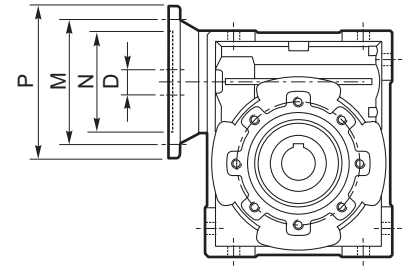

N.B. Las áreas grises indican los tamaño de los motores aplicables.

N.B. As áreas cinzas indicam o tamanho dos motores aplicados.

N.B. Grey areas indicate motor inputs available on each size of unit.

B/BS = Casquillo de reducción en acero

B/BS = Bucha de redução em aço

B/BS = Metal shaft sleeve

Note: Brida Nema disponible según la demanda

Nota: flange Nema disponível sob encomenda

Note: Nema flange available on demand

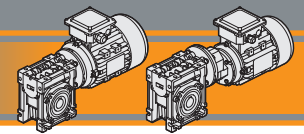

Motores aplicables

Motores aplicáveis

IEC Motor adapters

	IEC	N	M	P	D	i												
						5	7.5	10	15	20	25	30	40	50	60	80	100	
CM090	100/112B5	180	215	250	28													
	100/112B14	110	130	160														
	90B5	130	165	200	24	B	B	B	B	B	B	B						
	90B14	95	115	140														
	80B5	130	165	200	19	BS	BS	BS	BS	BS	BS	BS	B	B	B			
	80B14	80	100	120														
	71B5	110	130	160	14									BS	BS	BS	B	
CM110	132B5	230	265	300	38													
	132B14	130	165	200														
	100/112B5	180	215	250	28	B	B	B	B	B	B							
	100/112B14	110	130	160														
	90B5	130	165	200	24	BS	BS	BS	BS	BS	BS	B	B	B				
	90B14	95	115	140														
	80B5	130	165	200	19							BS	BS	BS	B	B		
CM130	132B5	230	265	300	38													
	132B14	130	165	200														
	100/112B5	180	215	250	28	B	B	B	B	B	B							
	90B5	130	165	200	24	BS	BS	BS	BS	BS	BS	B	B	B	B			
	80B5	130	165	200	19								BS	BS	BS	BS		
CM150	160B5	250	300	350	42													
	132B5	230	265	300	38	B	B	B	B	B								
	100/112B5	180	215	250	28	BS	BS	BS	BS	BS	B	B	B	B				

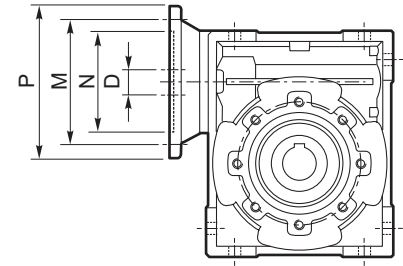

N.B. Las áreas grises indican los tamaño de los motores aplicables.

N.B. As áreas cinzas indicam o tamanho dos motores aplicados.

N.B. Grey areas indicate motor inputs available on each size of unit.

B/BS = Casquillo de reducción en acero

B/BS = Bucha de redução em aço

B/BS = Metal shaft sleeve

CM/CMP

Note: Brida Nema disponible según la demanda

Nota: flange Nema disponível sob encomenda

Note: Nema flange available on demand

CMP	IEC	N	M	P	D	i (i ₁ x i ₂)											
						60 (3x20)	75 (3x25)	90 (3x30)	120 (3x40)	150 (3x50)	180 (3x60)	240 (3x80)	300 (3x100)				
056/030	56 B14	50	65	80	9												
056/040						B	B	B	B								
063/040	63 B14	60	75	90	11												
063/050						B	B	B									
063/063						BS	BS	BS	B	B	B						
071/050	71 B14	70	85	105	14												
071/063						B	B	B									
071/070						B	B	B	B								
071/075						B	B	B	B								
071/090						BS	BS	BS	B	B	B						
080/063	80 B14	80	100	120	19												
080/070																	
080/075																	
080/090						B	B	B									
080/110						BS	BS	B	B	B	B						
080/130						BS	BS	BS	BS	B	B	B	B				
090/070						90 B14 90 B5	95 130	115 165	140 200	24							
090/075																	
090/090	B	B	B														
090/110	BS	BS	B	B	B						B						
090/130	BS	BS	BS	BS	B						B	B	B				
090/130	BS	BS	BS	BS	B						B	B	B				

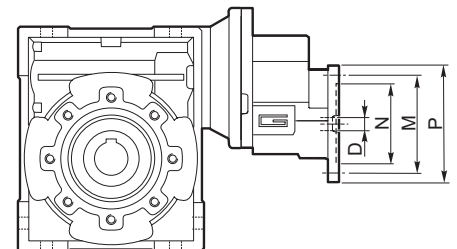

N.B. Las áreas grises indican los tamaño de los motores aplicables

N.B. As áreas cinzas indicam o tamanho dos motores aplicados

N.B. Grey areas indicate motor inputs available on each size of unit.

B/BS = Casquillo de reducción en acero

B/BS = Bucha de redução em aço

B/BS = Metal shaft sleeve



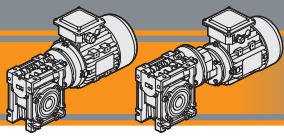

Dimensiones

Dimensões

Dimensions

CM 026 U

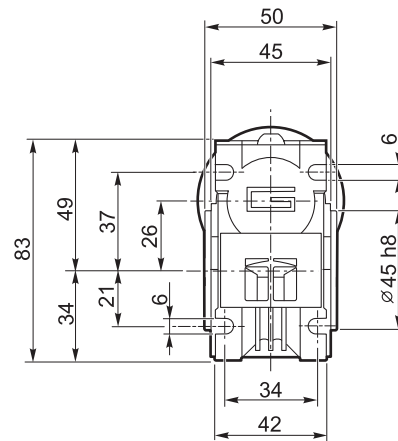
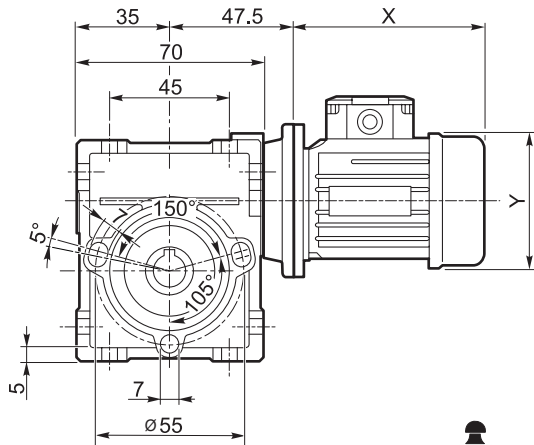

Kg
0.8

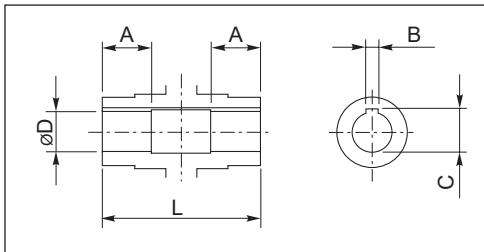

Eje de salida hueco
 Eixo saída vazado
 Hollow output shaft

Grandezza Size	ø D H8	L	A	B	C
CM 026 (D14)	14	50	15	5	16.2
CM 026	12	50	15	4	13.8
CM 026 (D11)	11	50	15	4	12.8

CMIS 026 ..

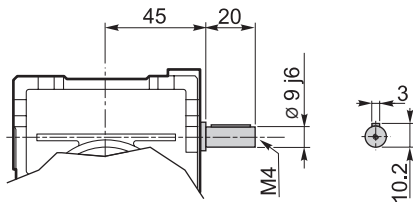

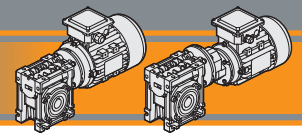

Dimensiones

Dimensões

Dimensions

CM 026 F

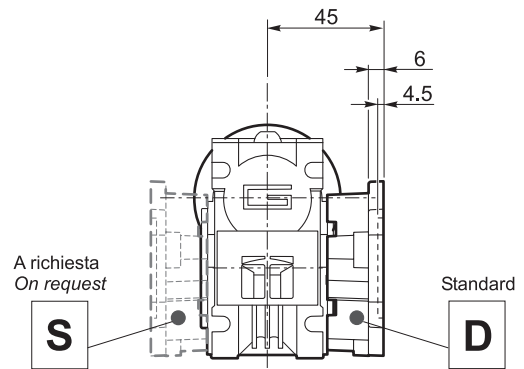
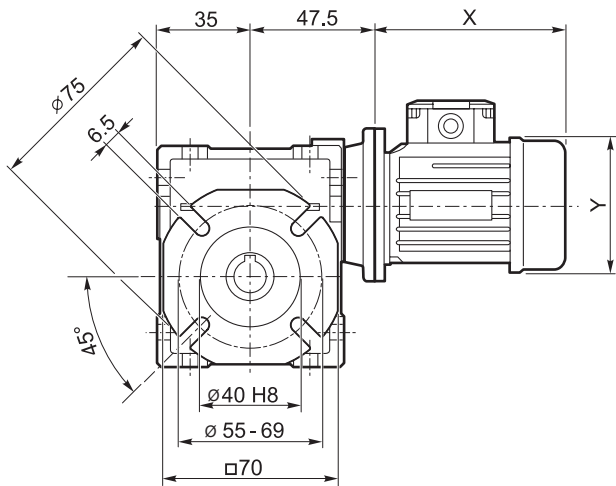

CM 026 F28

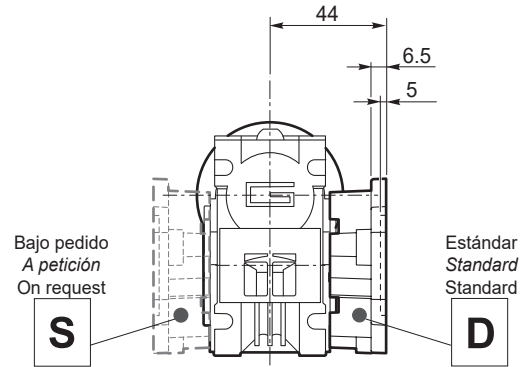
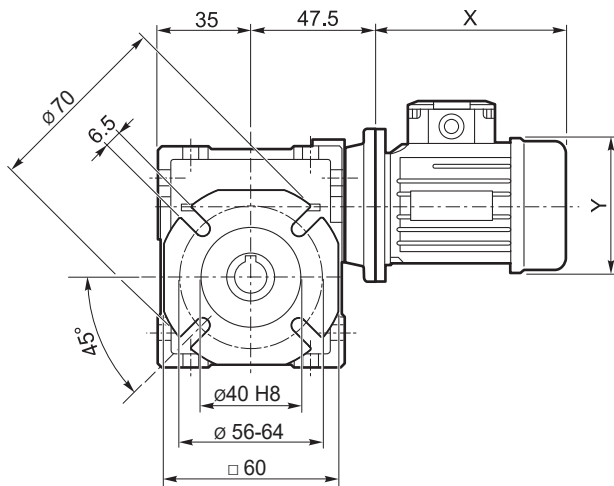

CM 026 F30

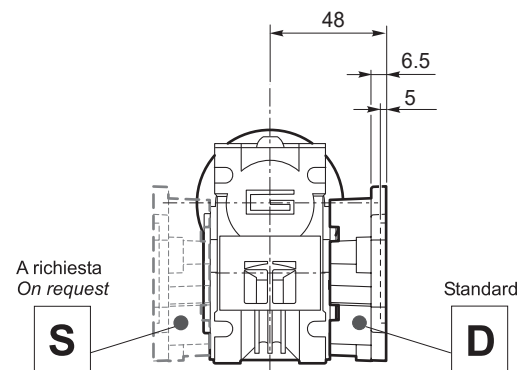
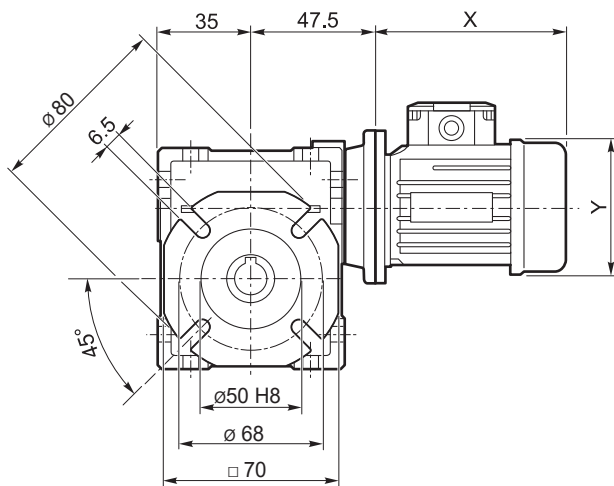

CM/CMP

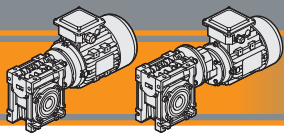

Dimensiones

Dimensões

Dimensions

CM 030 U

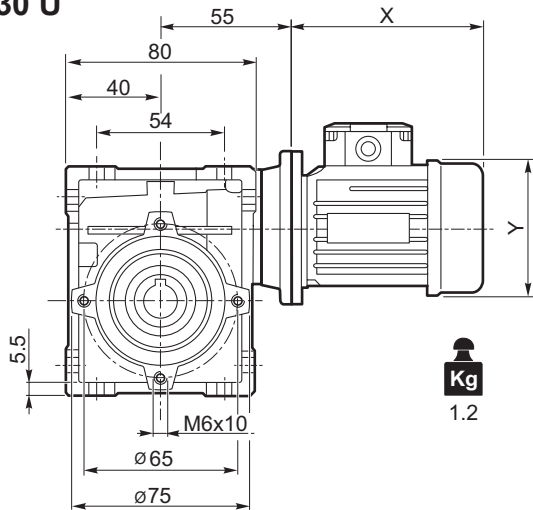

Kg
1.2

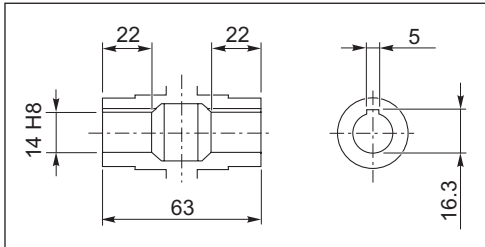
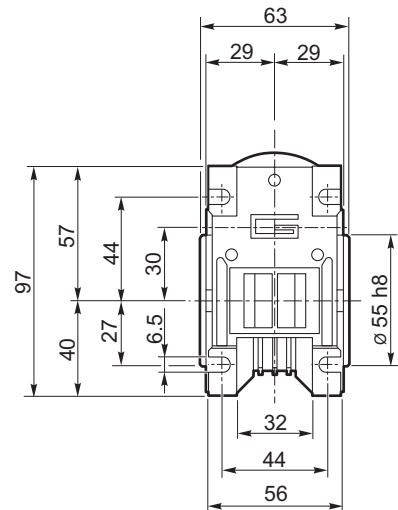

Eje de salida hueco
 Eixo saída vazado
 Hollow output shaft

CMIS 030 ..

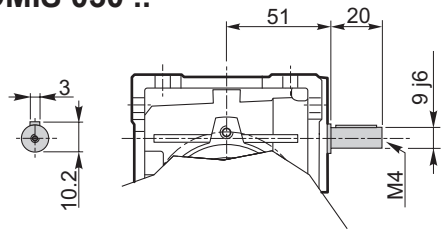

CMP ..

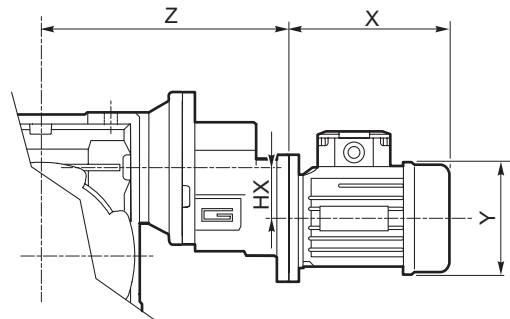

	HX	Z	Kg
056/030	30.5	124	2.1

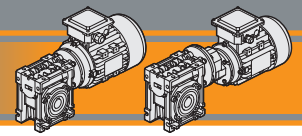

Dimensiones

Dimensões

Dimensions

CM 030 F

CMP../030 F

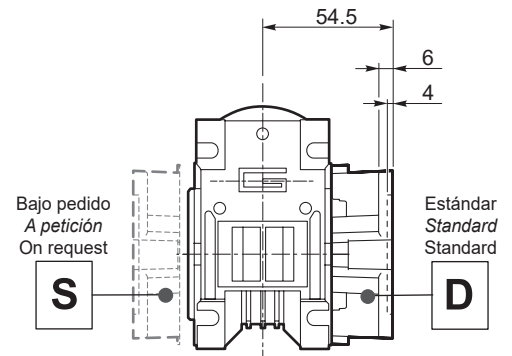
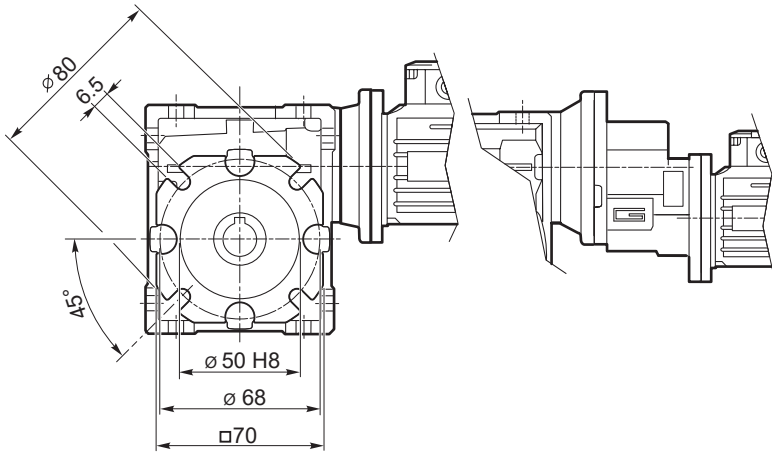

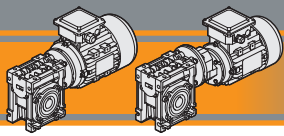

Dimensiones

Dimensões

Dimensions

CM 040 U

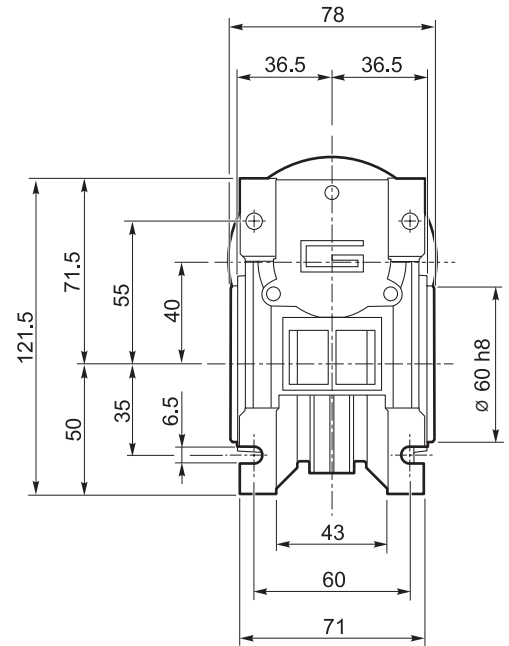
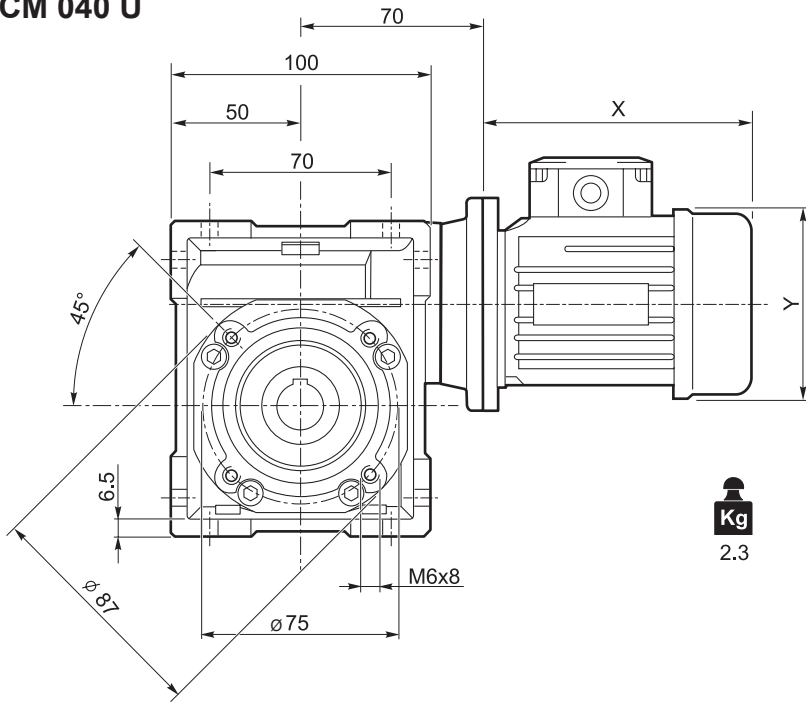

CMIS 040 ..

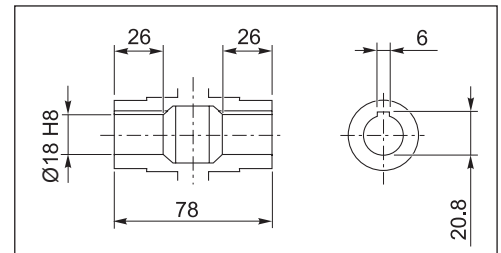
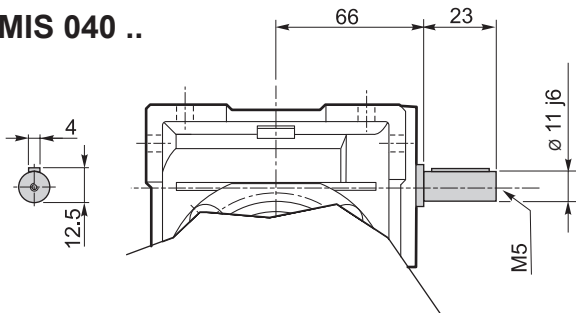

Eje de salida hueco
 Eixo saída vazado
 Hollow output shaft

CMP ..

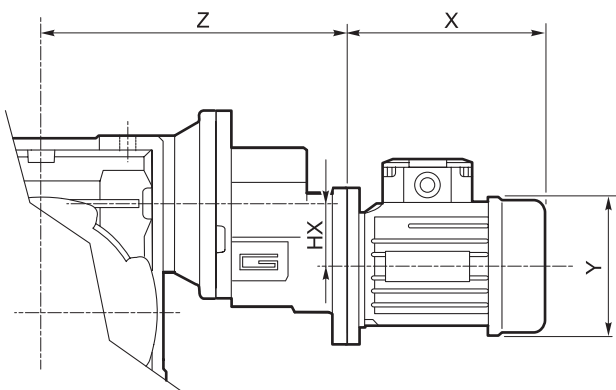

	HX	Z	Kg
056/040	30.5	139	3.2
063/040	30.5	142	3.3

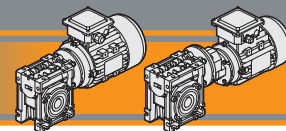

Dimensiones

Dimensões

Dimensions

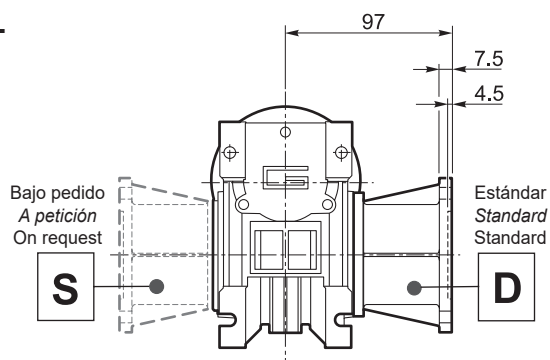
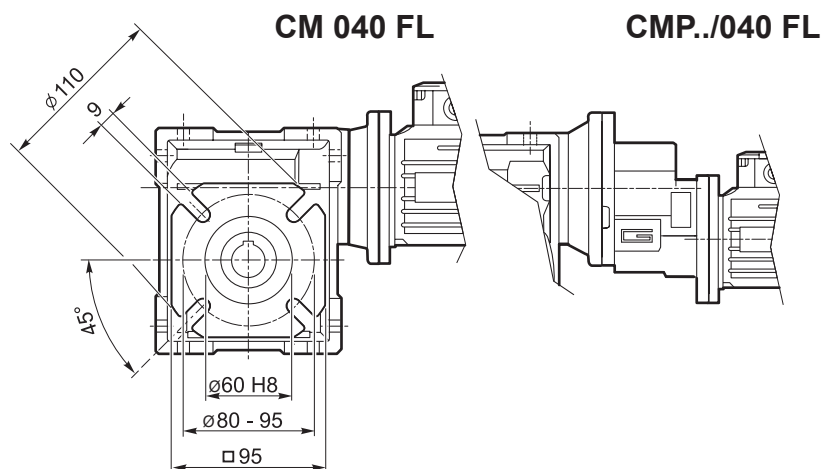
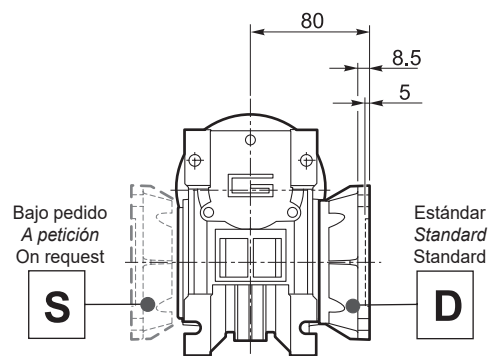
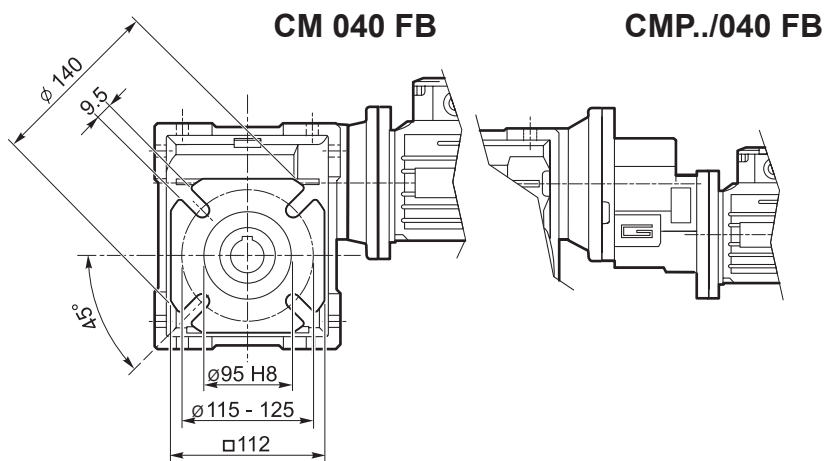
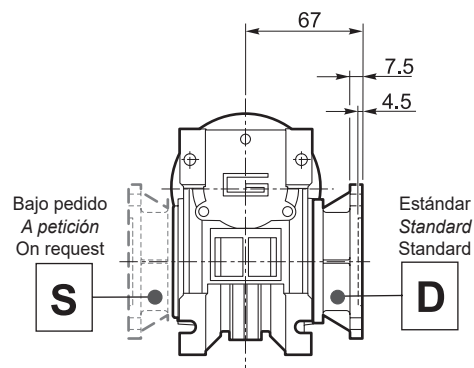
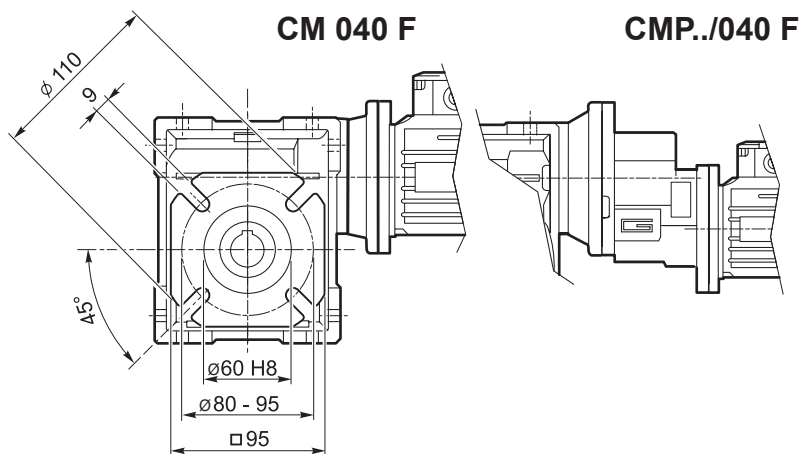

CM/CMP

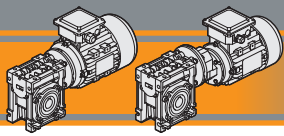

Dimensiones

Dimensões

Dimensions

CM 050 U

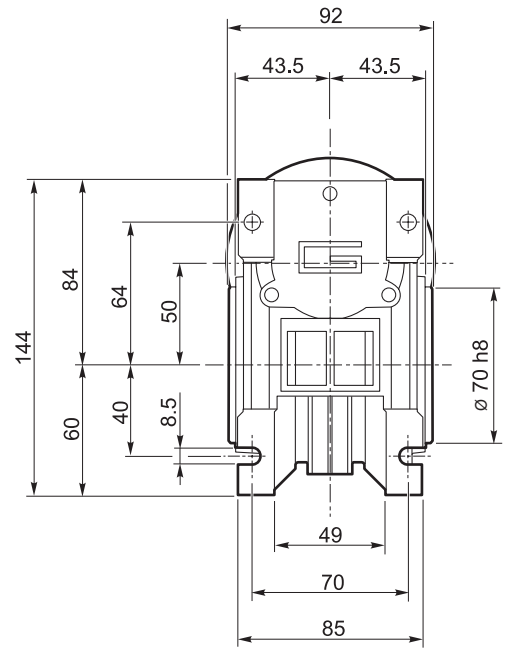
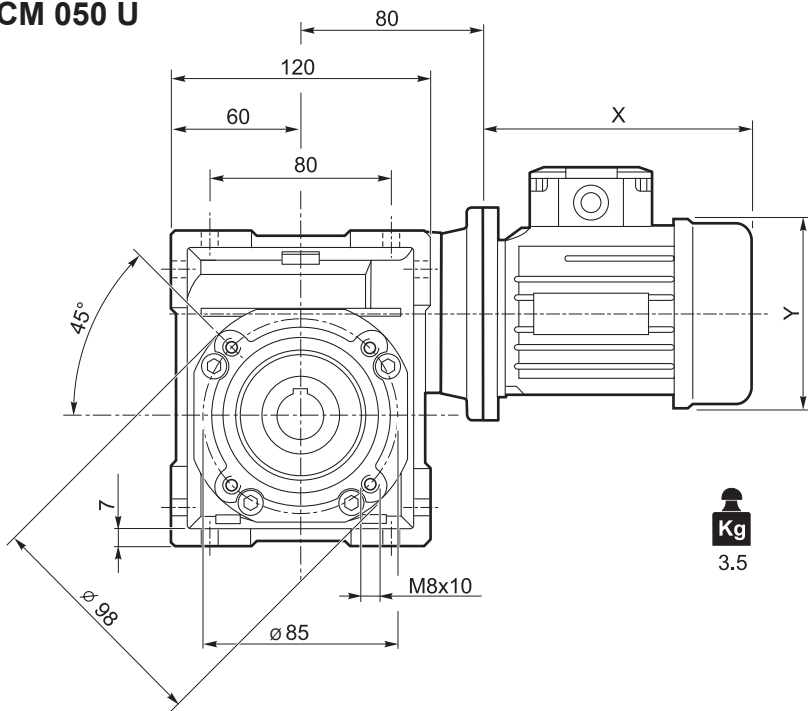

CMIS 050 ..

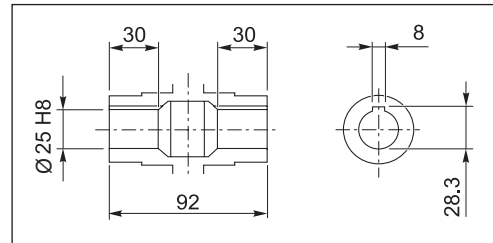
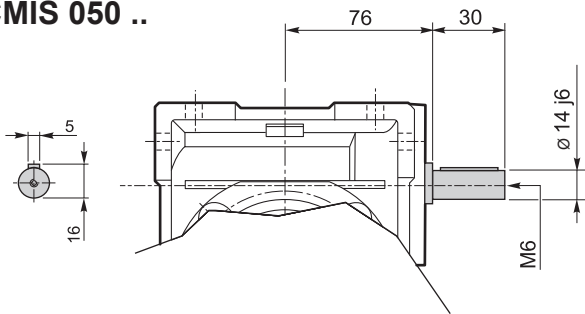

Eje de salida hueco
 Eixo saída vazado
 Hollow output shaft

CMP ..

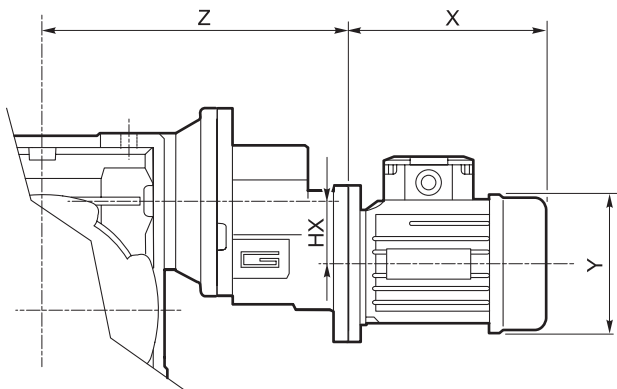

	HX	Z	Kg
063/050	30.5	152	4.5
071/050	41	169	5.5

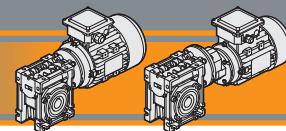

Dimensiones

Dimensões

Dimensions

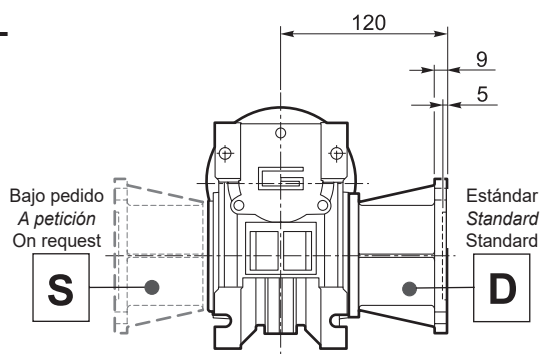
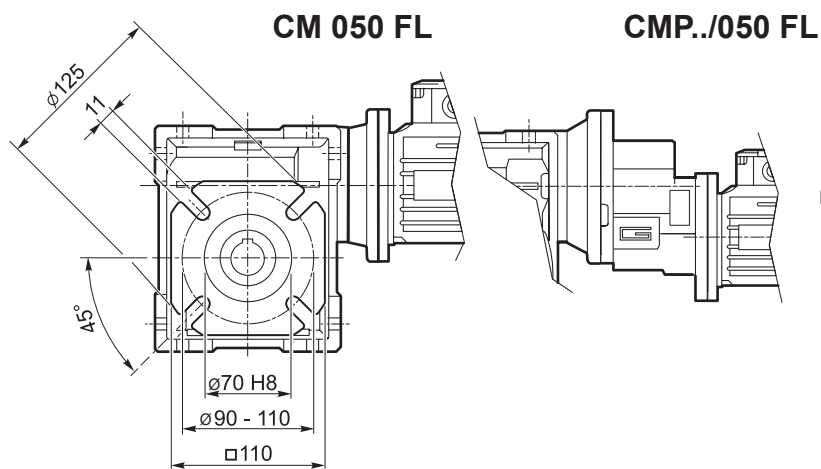
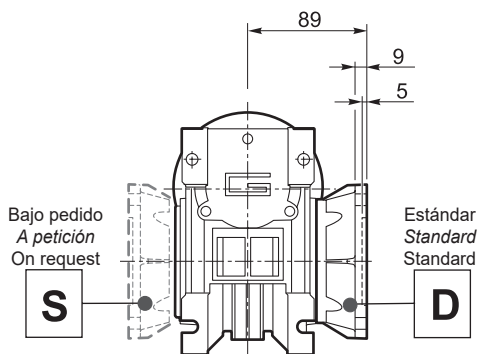
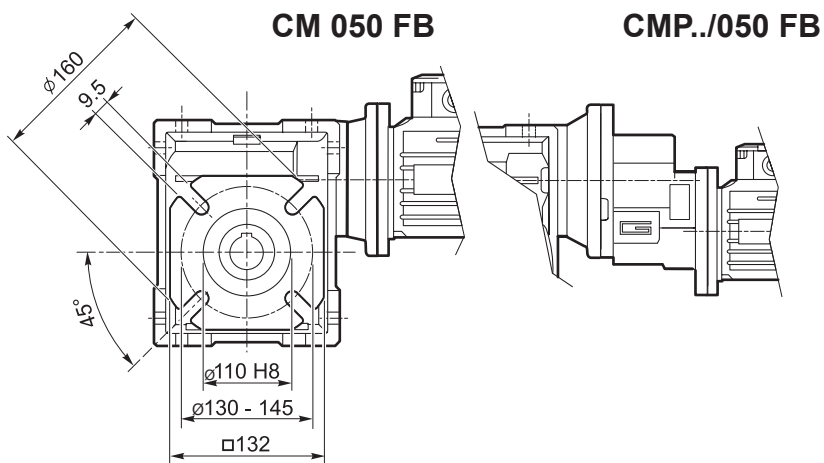
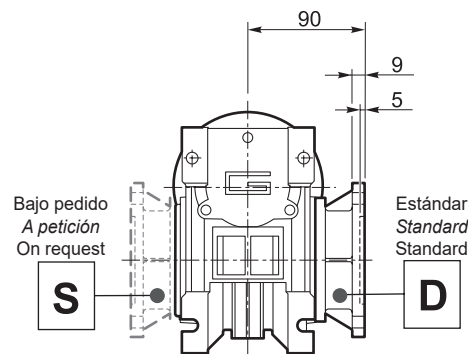
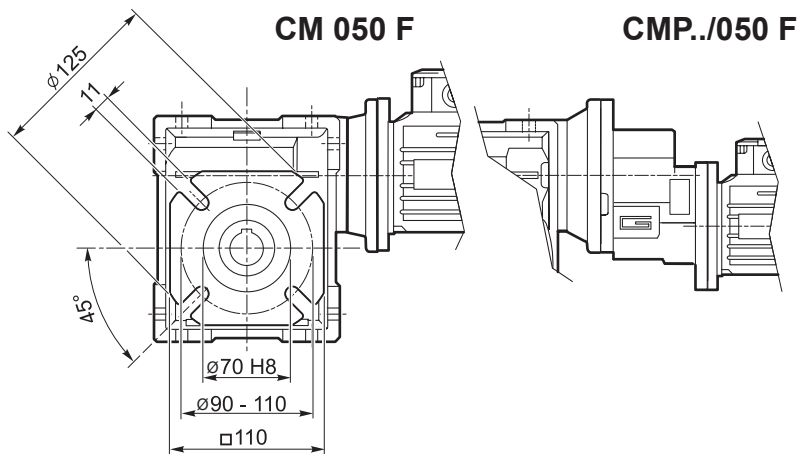

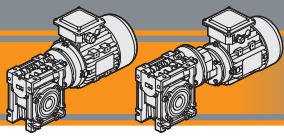

Dimensiones

Dimensões

Dimensions

CM 063 U

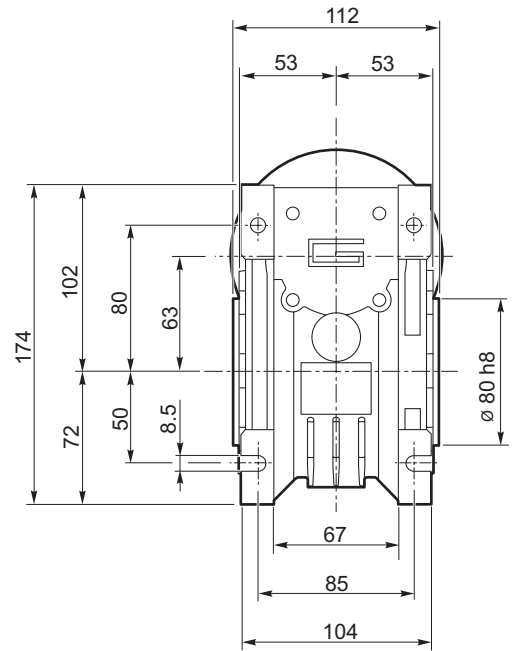
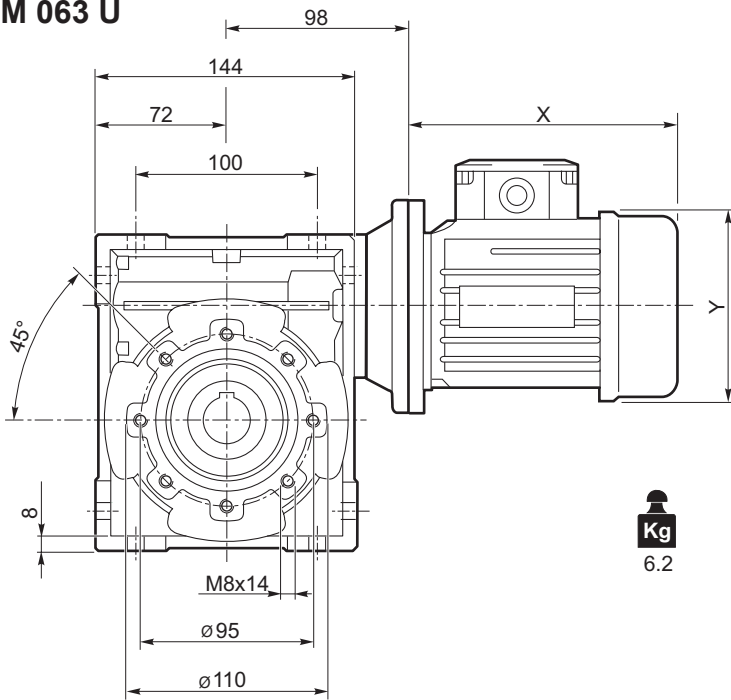

CMIS 063 ..

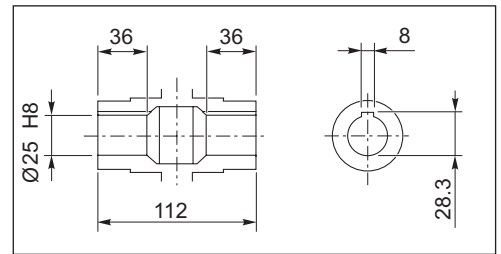
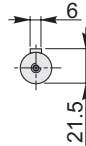
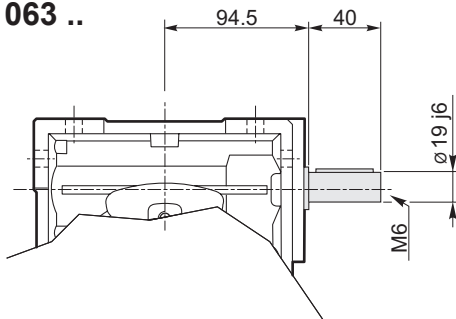

Eje de salida hueco
 Eixo saída vazado
 Hollow output shaft

CMP ..

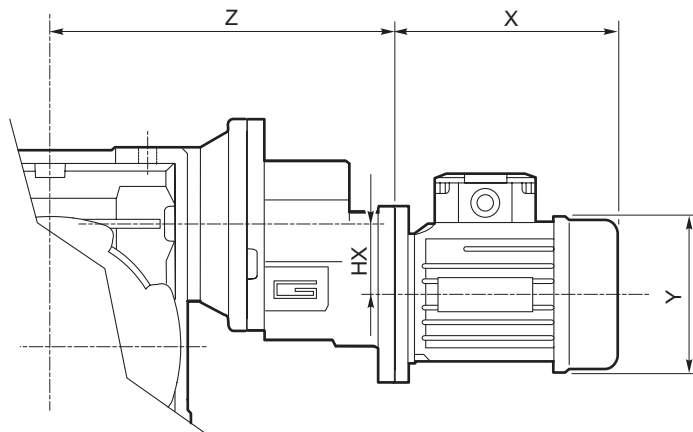

	HX	Z	Kg
063/063	30.5	170	7.2
071/063	41	187	8.2
080/063	41	198	9.0

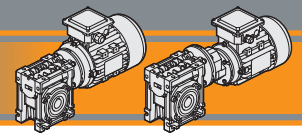

Dimensiones

Dimensões

Dimensions

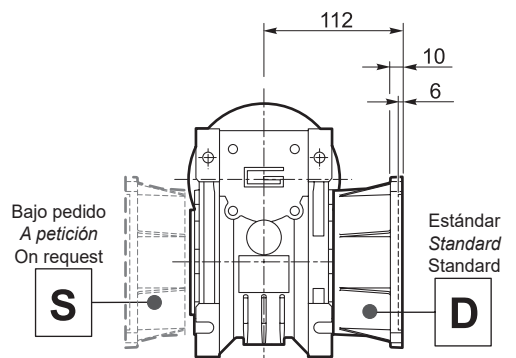
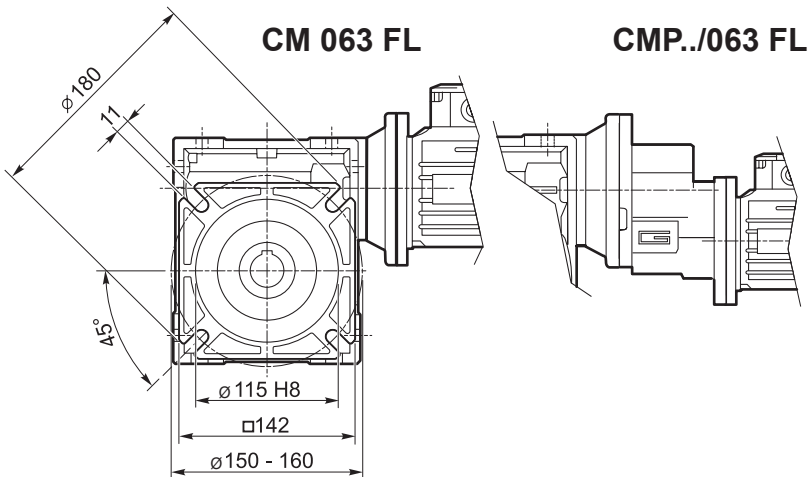
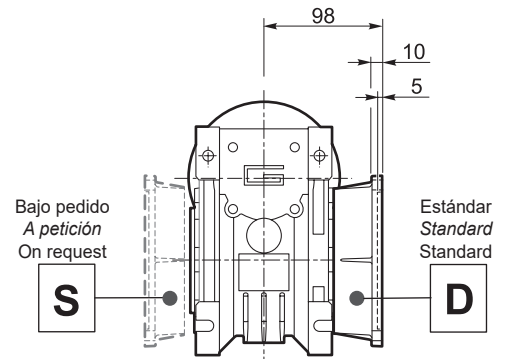
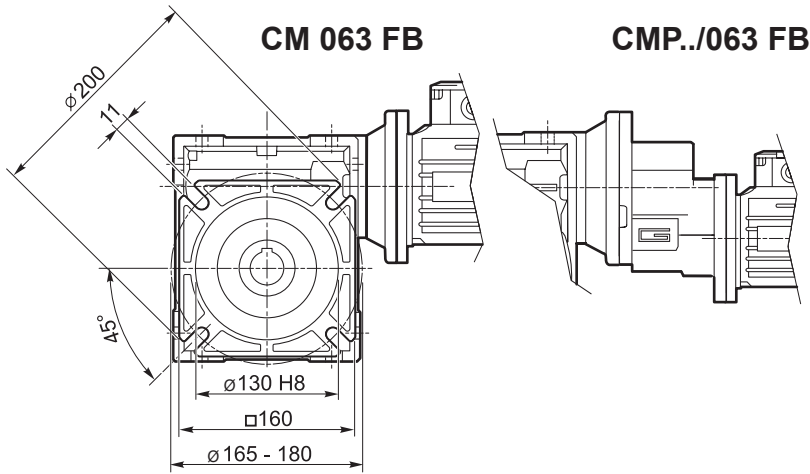
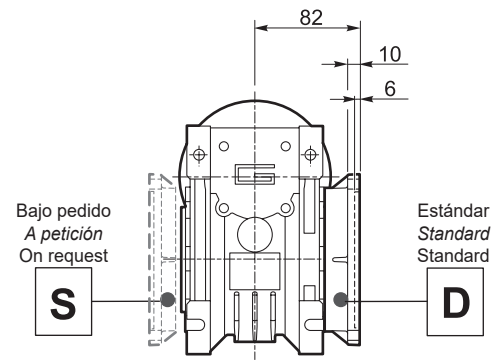
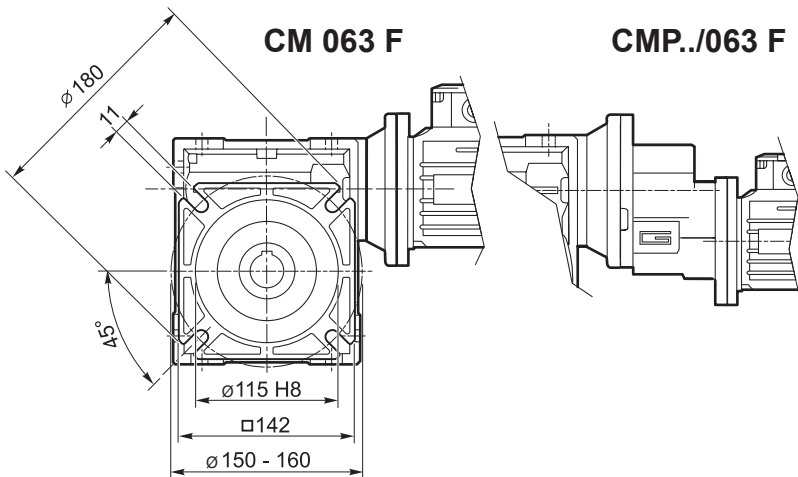

CM/CMP

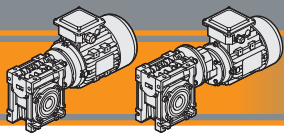

Dimensiones

Dimensões

Dimensions

CM 070 U

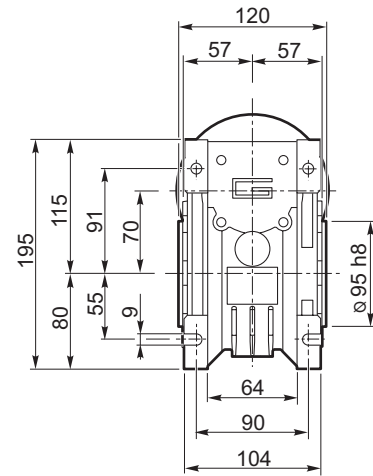
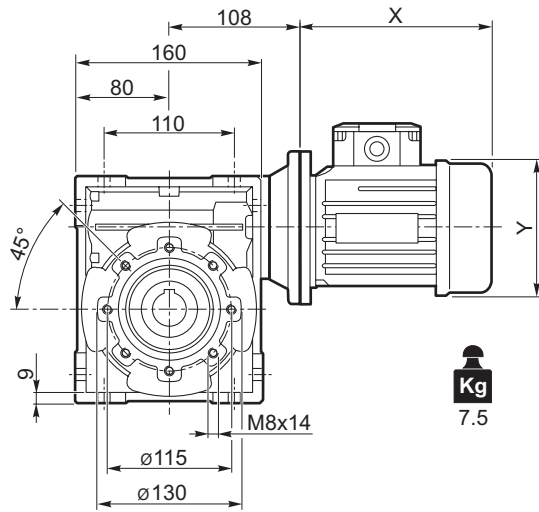

CM 070 F

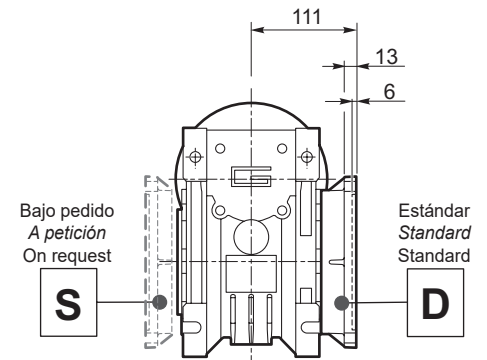
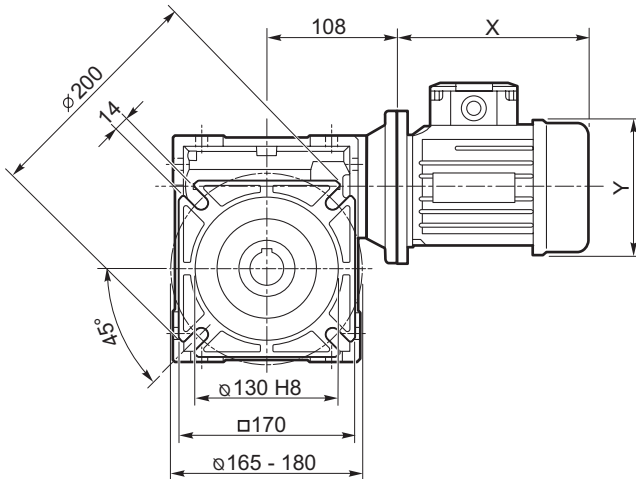

CMIS 070 ..

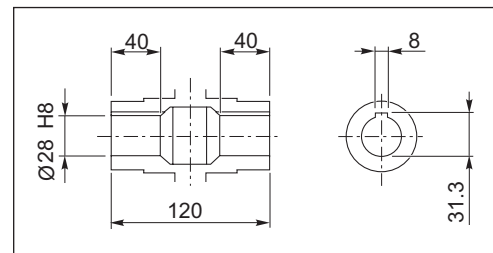
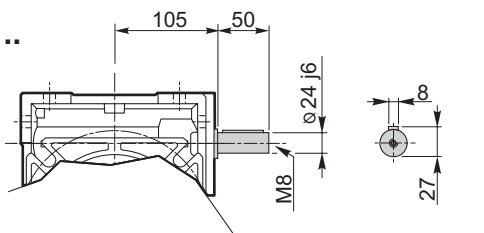

Eje de salida hueco
 Eixo saída vazado
 Hollow output shaft

CMP ..

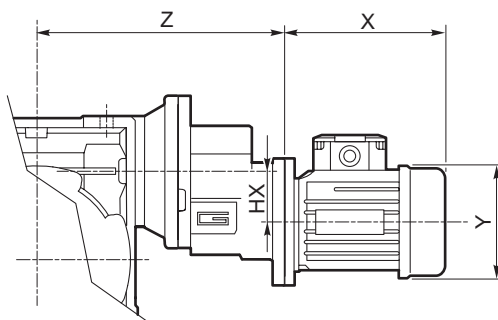

	HX	Z	Kg
071/070	41	197	9
080/070	41	208	9.8
090/070	36.5	262	10.5

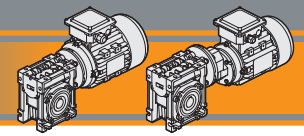

Dimensiones

Dimensões

Dimensions

CM 075 U

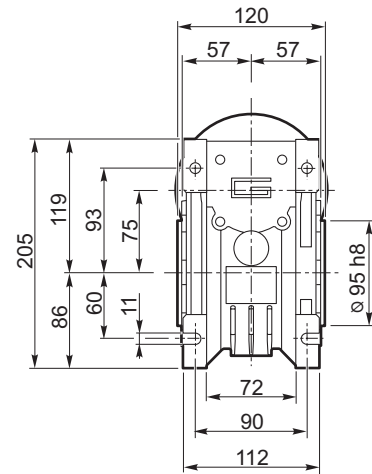
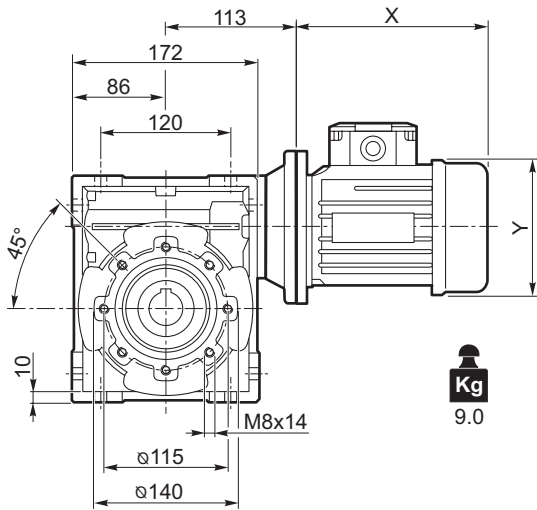

CM 075 F

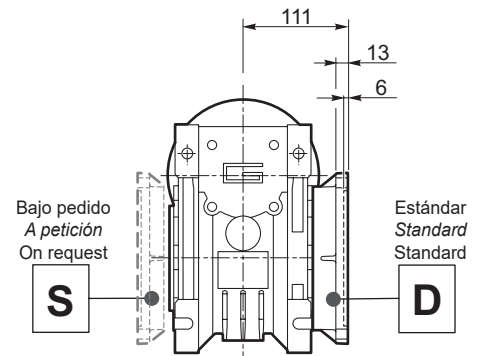
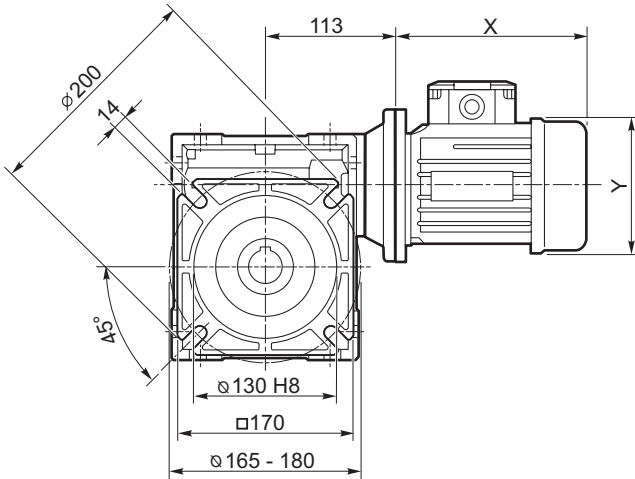

CM/CMP

CMIS 075 ..

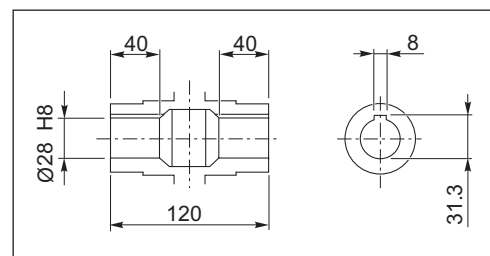
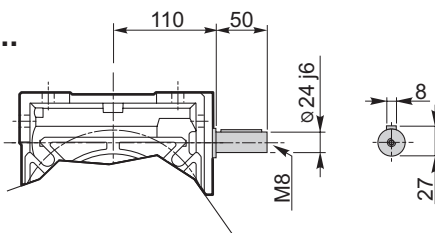

Eje de salida hueco
 Eixo saída vazado
 Hollow output shaft

CMP ..

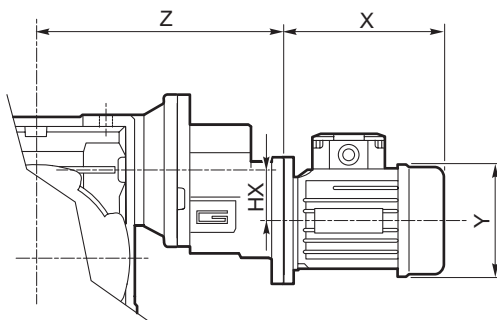

	HX	Z	Kg
071/075	41	202	11.0
080/075	41	213	11.8
090/075	36.5	267	12.5

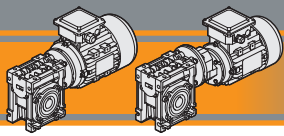

Dimensiones

Dimensões

Dimensions

CM 090 U

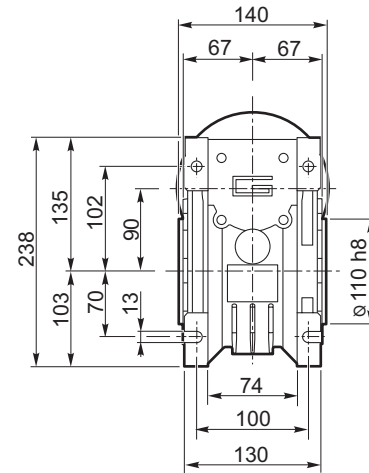
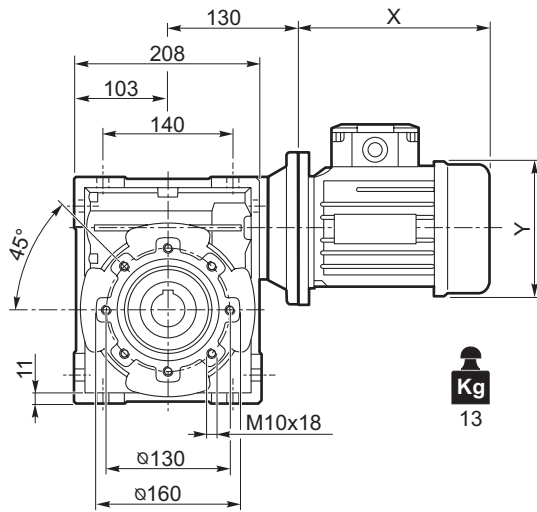

CM 090 F

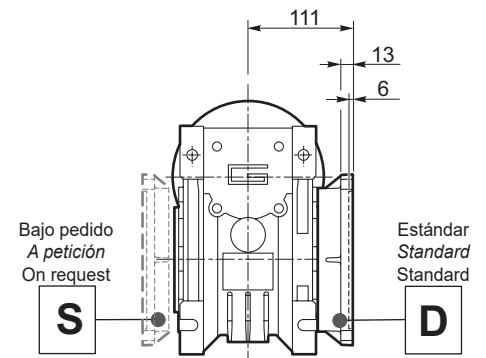
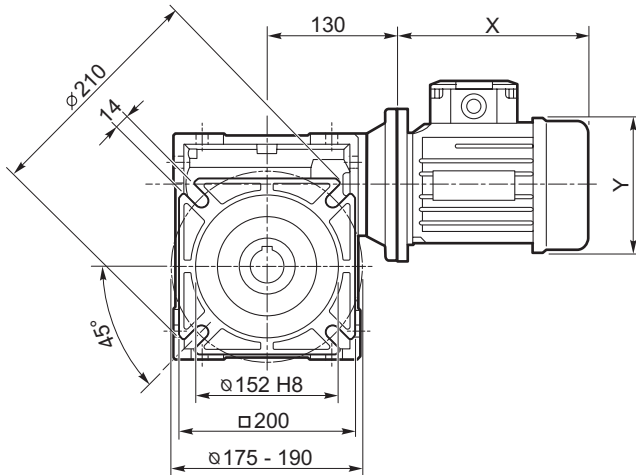

CMIS 090 ..

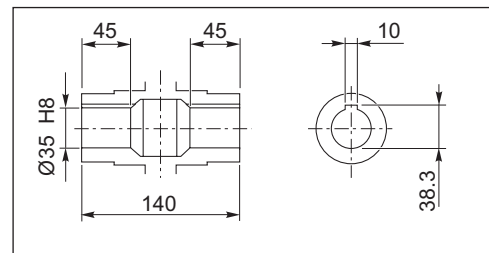
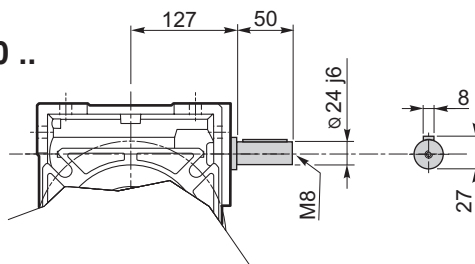

Eje de salida hueco
 Eixo saída vazado
 Hollow output shaft

CMP ..

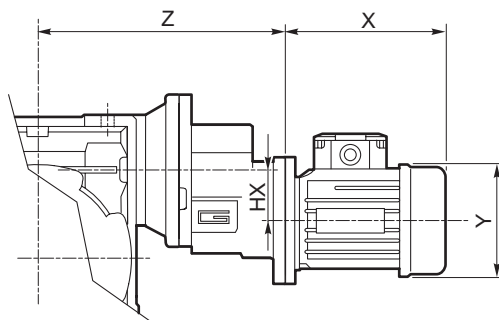

	HX	Z	Kg
071/090	41	219	15.0
080/090	41	230	15.8
090/090	36.5	284	16.5

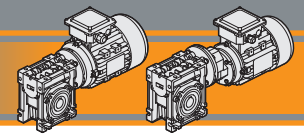

Dimensiones

Dimensões

Dimensions

CM 110 U

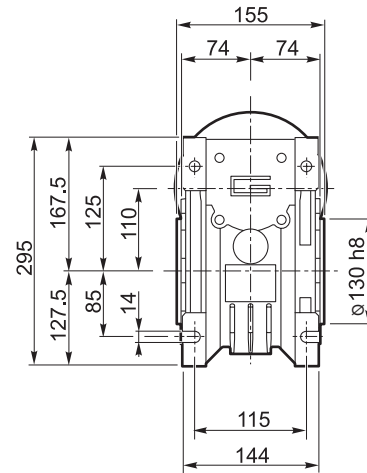
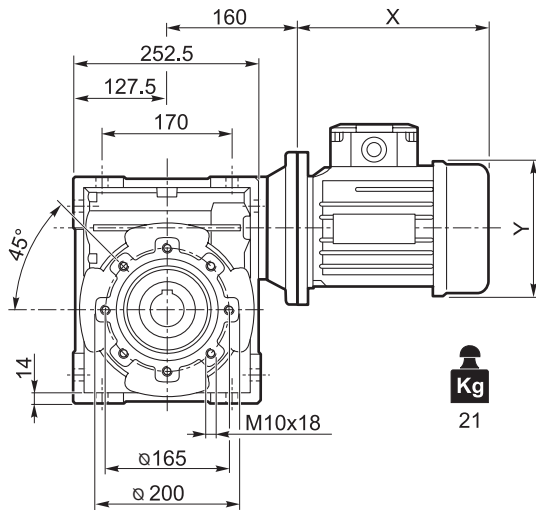

CM 110 F

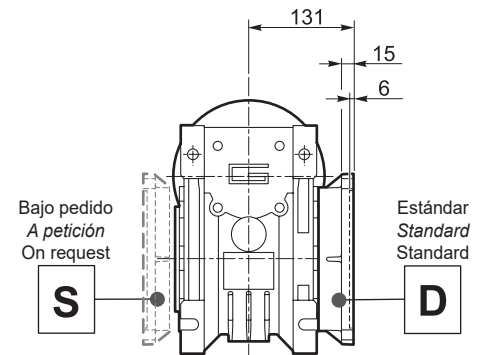
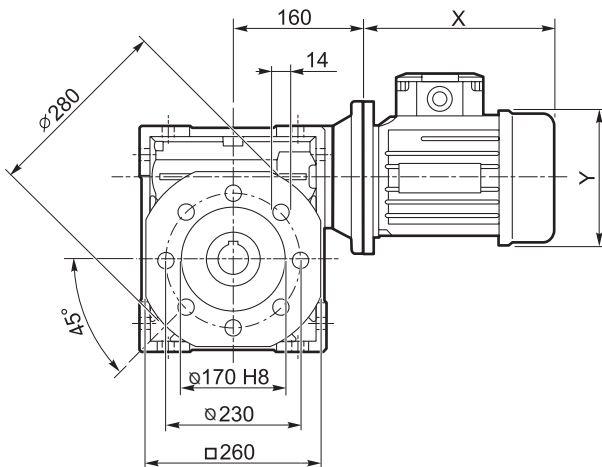

CMIS 110 ..

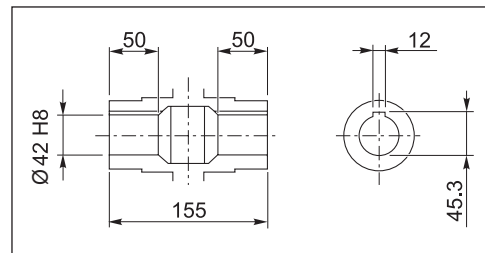
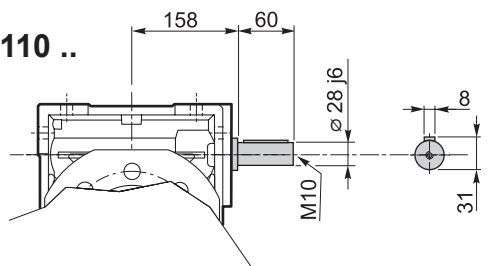

Eje de salida hueco
 Eixo saída vazado
 Hollow output shaft

CMP ..

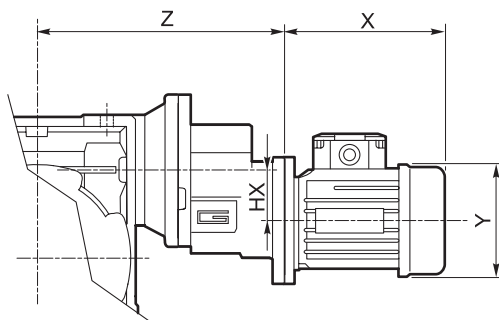

	HX	Z	Kg
080/110	41	260	23.8
090/110	36.5	314	24.5

CM/CMP

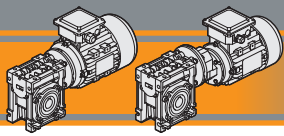

Dimensiones

Dimensões

Dimensions

CM 130 U

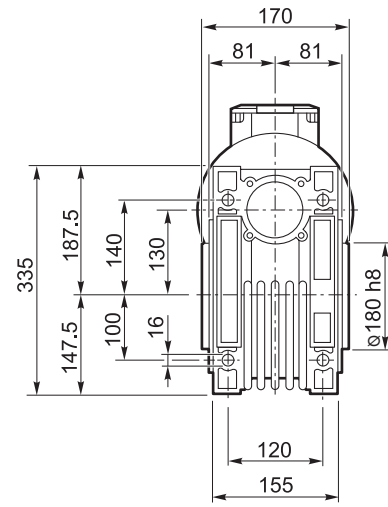
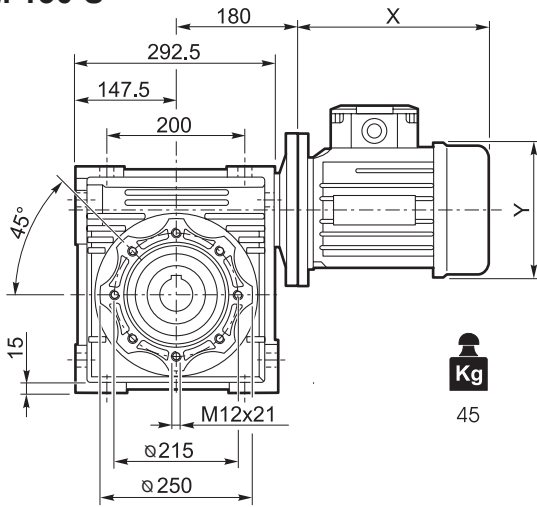

CM 130 F

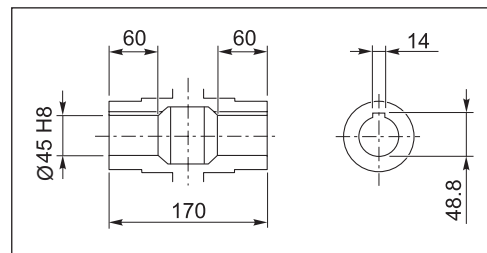
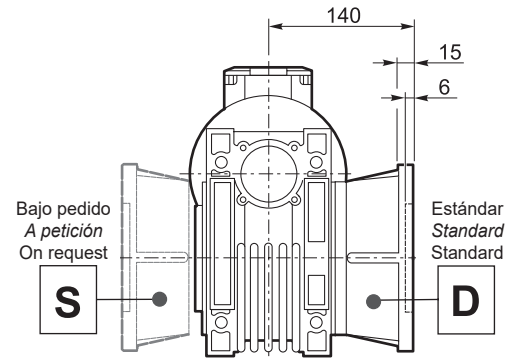
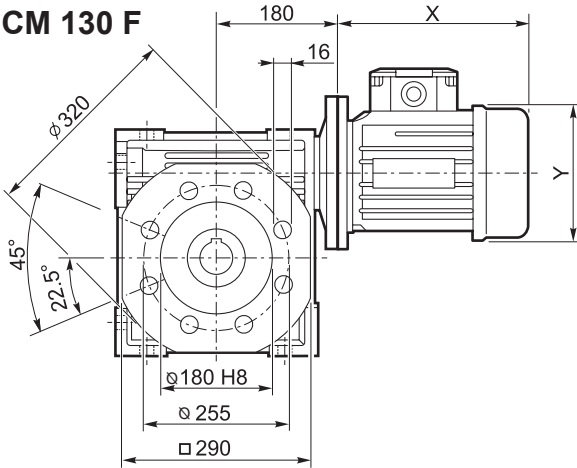

Eje de salida hueco
 Eixo saída vazado
 Hollow output shaft

CMP ..

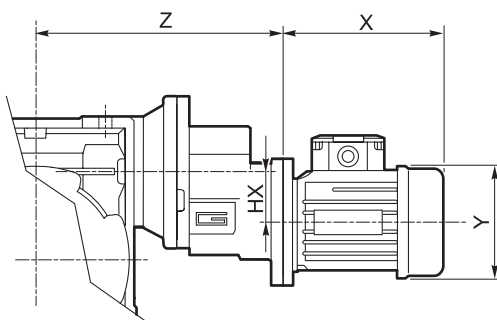

	HX	Z	Kg
080/130	41	280	47.8
090/130	36.5	334	48.5

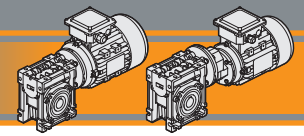

Dimensiones

Dimensões

Dimensions

CM 150 U

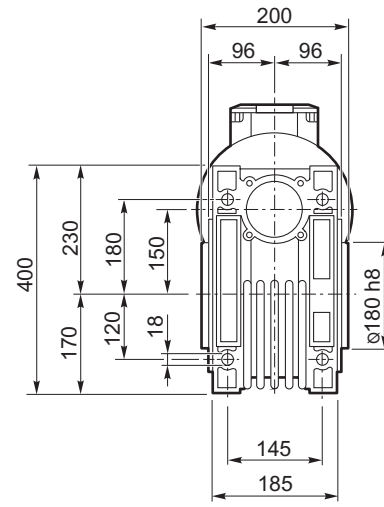
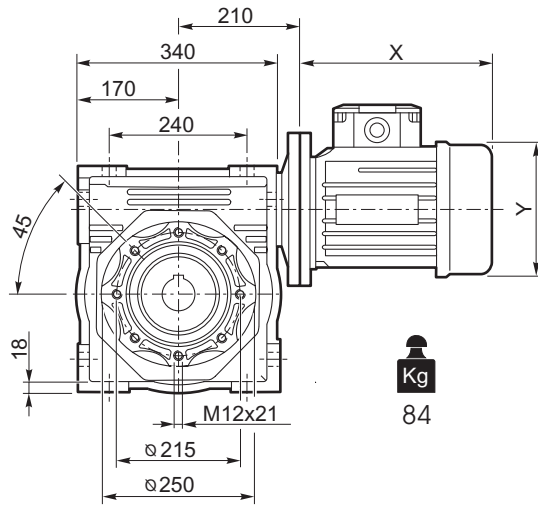

CM 150 F

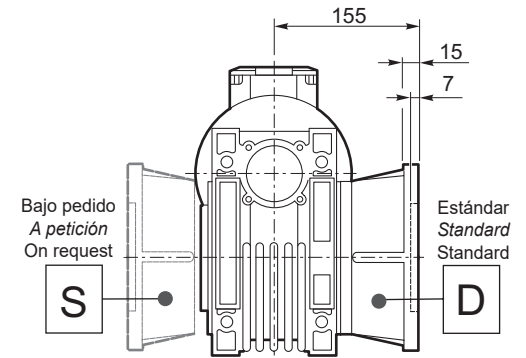
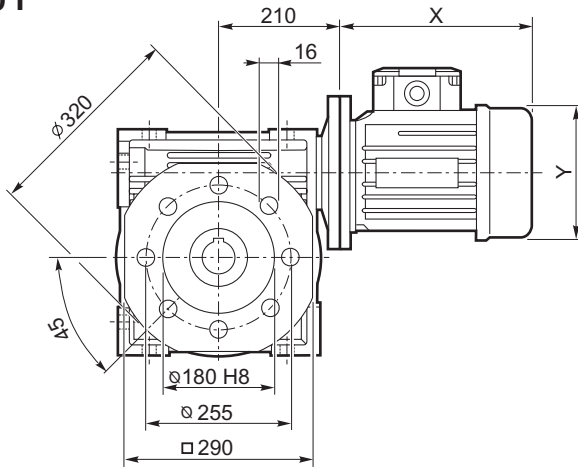

Note: Pedido especial
Nota: Item sob pedido especial
Note: Special order item

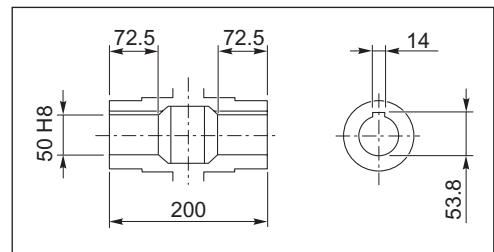

Eje de salida hueco
 Eixo saída vazado
 Hollow output shaft

CM/CMP

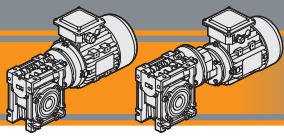

Accesorios

Acessórios

Accessories

Eje de salida simple y doble

Eixo lenta simples e dupla

Single and double output shaft

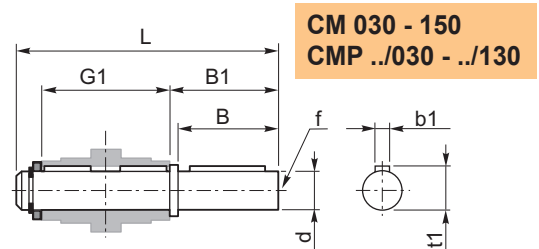
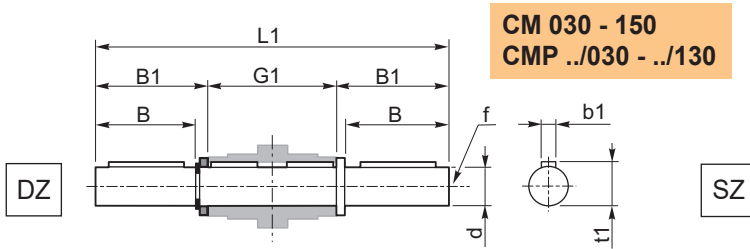

CM	CMP	d _{h7}	B	B1	G1	L	L1	f	b1	t1
030	056/030	14	30	32.5	63	102	128	M6	5	16
040	056/040 063/040	18	40	43	78	128	164	M6	6	20.5
050	063/050 071/050	25	50	53.5	92	153	199	M10	8	28
063	063/063 071/063 080/063	25	50	53.5	112	173	219	M10	8	28
075	071/075 080/075 090/075	28	60	63.5	120	192	247	M10	8	31
090	071/090 080/090 090/090	35	80	84.5	140	234	309	M12	10	38
110	080/110 090/110	42	80	84.5	155	249	324	M16	12	45
130	080/130 090/130	45	80	85	170	265	340	M16	14	48.5
150	—	50	82	87	200	297	374	M16	14	53.5

CM 026 (*)

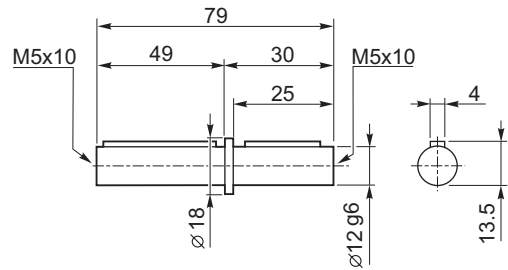

(*)
Nota: disponible solo para eje de salida hueco Ø12
Note: disponível somente para eixo de saída oco de Ø12
Note: available for output hollow shaft Ø12 only

Brazo de reacción

Braço de reação

Torque arm

CM	CMP	K1	G	KG	KH	R
030	056/030	85	14	23	8	15
040	056/040 063/040	100	14	31	10	18
050	063/050 071/050	100	14	38	10	18
063	063/063 071/063 080/063	150	14	47.5	10	18
075	071/075 080/075 090/075	200	25	46.5	20	30
090	071/090 080/090 090/090	200	25	56.5	20	30
110	080/110 090/110	250	30	62	25	35
130	080/130 090/130	250	30	69	25	35
150	—	250	30	84	25	35

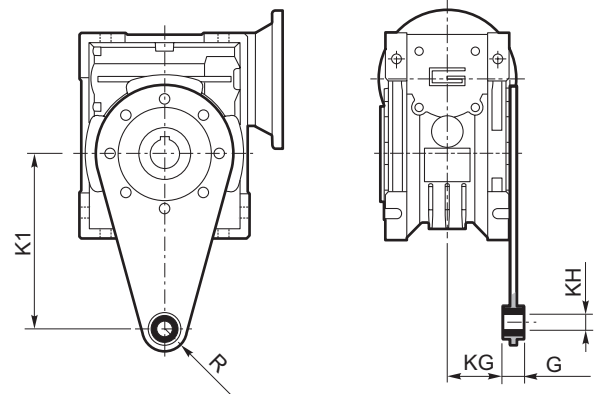

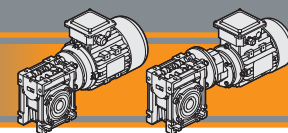

SC - Cubierta de seguridad / Tampa de proteção / Safety cover

CM	CMP	M
030	056/030	47
040	056/040 063/040	54.5
050	063/050 071/050	62.5
063	063/063 071/063 080/063	73
075	071/075 080/075 090/075	79
090	071/090 080/090 090/090	94
110	080/110 090/110	102
130	080/130 090/130	117
150	—	113

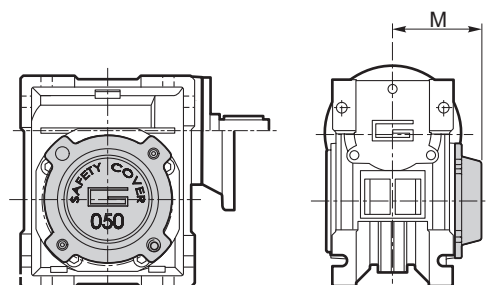

Opciones

Opções

Options

VS - Tornillo sinfín sobresaliente / Parafuso saliente / Extended input shaft

CM	CMP	A	B	D ₁ j6	E	F	G
030	056/030	45	20	9	M4	3	10.2
040	056/040 063/040	53	23	11	M5	4	12.5
050	063/050 071/050	64	30	14	M6	5	16
063	063/063 071/063 080/063	75	40	19	M6	6	21.5
070	071/070 080/070 090/070	84	40	19	M6	6	21.5
075	071/075 080/075 090/075	90	50	24	M8	8	27
090	071/090 080/090 090/090	108	50	24	M8	8	27
110	080/110 090/110	135	60	28	M10	8	31
130	080/130 090/130	—	—	—	—	—	—
150	—	—	—	—	—	—	—

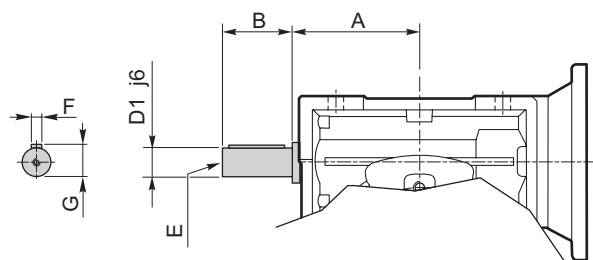

Construido bajo pedido / Fabricado sob encomenda / Built on request

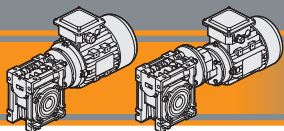

CM/CMP

Motorreductores sinfín corona
Motoredutores de rosca sem fim
Wormgearmotors

60 Hz

Note/Notes