

TRANSTECNO[®]
the modular gearmotor

NDCM

NDCM



Neodymium

Motoriduttori CC a vite senza fine
DC wormgearmotors

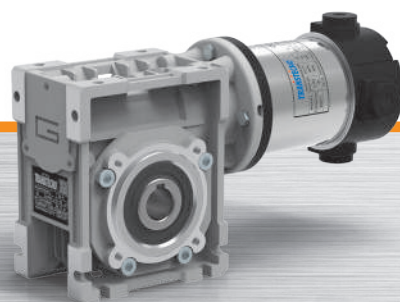

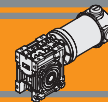

Indice	Index	Pag. Page
Caratteristiche tecniche	<i>Technical features</i>	F2
Designazione	<i>Classification</i>	F2
Simbologia	<i>Symbols</i>	F2
Lubrificazione	<i>Lubrication</i>	F3
Carichi radiali	<i>Radial loads</i>	F3
Dati di dentatura	<i>Toothing data</i>	F4
Rendimento	<i>Efficiency</i>	F4
Dati tecnici	<i>Technical data</i>	F5
Motori applicabili	<i>IEC Motor adapters</i>	F5
Dimensioni	<i>Dimensions</i>	F6
Opzioni	<i>Options</i>	F10
Accessori	<i>Accessories</i>	F11

Questa sezione annulla e sostituisce ogni precedente edizione o revisione. Qualora questa sezione non Vi sia giunta in distribuzione controllata, l'aggiornamento dei dati ivi contenuto non è assicurato. **In tal caso la versione più aggiornata è disponibile sul nostro sito internet www.transtecno.com**

This section replaces any previous edition and revision. If you obtained this catalogue other than through controlled distribution channels, the most up to date content is not guaranteed. In this case the latest version is available on our web site www.transtecno.com



Caratteristiche tecniche

Technical features

Le caratteristiche principali dei motoriduttori CC a vite senza fine a magneti permanenti in neodimio NDCM sono:

The main features of NDCM neodymium permanent magnets DC wormgearmotors range are:

- Alimentazione in bassa tensione 12/24 Vcc
- Possibilità di montaggio encoder e freno
- Potenze motore disponibili da 160 a 250 W S2
- Magneti in Neodimio
- Carcasse dei riduttori a vite senza fine in pressofusione di alluminio
- Lubrificazione permanente con olio sintetico
- Low voltage power supply 12/24 Vdc
- Suitable for encoder and brake assembly
- Motor power ratings available from 160 to 250 W S2
- Neodymium magnets
- Die-cast aluminum housing on wormgearboxes
- Permanent synthetic oil long-life lubrication

Designazione

Classification

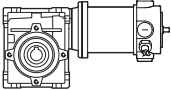
MOTORIDUTTORE / GEARMOTOR									
NDCM	120/030		U	10	SZDX	BRSX	90	240	VS
Tipo Type	Grandezza Size		Versione Riduttore Gearbox Version	Rapporto Ratio	Albero di uscita Output shaft	Braccio di reazione Torque arm	Angolo Angle	Versione Motore Motor Version	Opzioni Options
	120/026	180/026	U F...	Vedere tabella See tables	SZDX SZSX DZ	BRDX BRSX	0° 90° 180° 270°	120 — 240	VS
	120/026 (D11)	180/026 (D11)							
	120/026 (D14)	180/026 (D14)							
	120/030	180/030							
	120/040	180/040							

Versione Riduttore
Gearbox Version

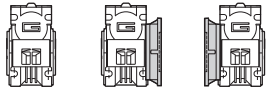

U F...D F...S

Albero di uscita
Output shaft

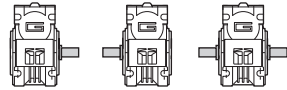

SZDX SZSX DZ

Braccio di reazione
Torque arm *

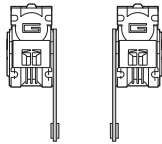

BRDX BRSX

Angolo
Angle

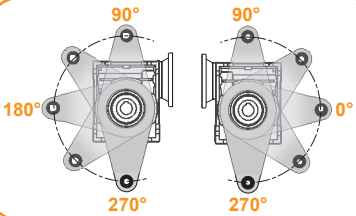

90° 90°
180° 0°
270° 270°

* NOTA: il braccio di reazione viene fornito smontato.
NOTE: the torque arm will be supplied not assembled.

Simbologia

Symbols

n_1	[min ⁻¹]	Velocità in ingresso / Input speed	R_d	%	Rendimento dinamico / Dynamic efficiency
n_2	[min ⁻¹]	Velocità in uscita / Output speed	A_2	[N]	Carico assiale ammissibile in uscita / Permitted output axial load
i		Rapporto di riduzione / Ratio	R_s	%	Rendimento statico / Static efficiency
P_1	[kW]	Potenza in entrata / Input power	R_2	[N]	Carico radiale ammissibile in uscita / Permitted output radial load
M_2	[Nm]	Coppia in uscita in funzione di P_1 / Output torque referred to P_1	Z		Numero di principi della vite / Worm starts
sf		Fattore di servizio / Service factor	β		Angolo d'elica / Helix angle



Lubrificazione

Lubrication

I riduttori a vite senza fine della serie CM sono lubrificati a vita con olio sintetico di viscosità 320 e possono essere installati in qualunque posizione di montaggio.

Permanent synthetic oil long-life lubrication allow to use CM wormgearbox range in all mounting position.

Carichi radiali

Radial loads

NDCM

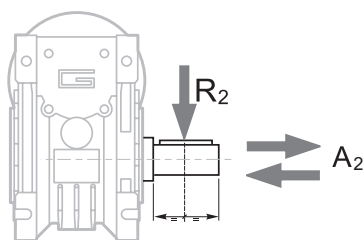

$$A_2 = R_2 \times 0.2$$

n ₂ [min ⁻¹]	R ₂ [N]		
	CM026	CM030	CM040
600	271	457	857
400	310	523	981
300	342	576	1080
200	391	659	1236
150	479	726	1361
120	514	782	1466
100	547	831	1558
75	609	914	1715
60	610	985	1847
50	-	1047	1963
38	-	1147	2151
30	-	1241	2327

Quando il carico radiale risultante non è applicato sulla mezzeria dell'albero occorre calcolare quello effettivo con la seguente formula:

When the resulting radial load is not applied on the centre line of the shaft it is necessary to calculate the effective load with the following formula:

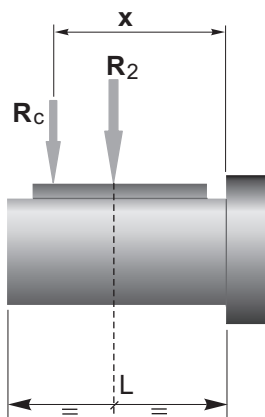

$$R_c = \frac{R_2 \cdot a}{(b+x)} \leq R_{2MAX}$$

$$R \leq R_c$$

a, b = valori riportati nella tabella
a, b = values given in the table

	CM		
	026	030	040
a	56	65	84
b	43	50	64
R _{2MAX}	610	1600	3000

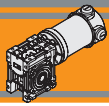

Dati di dentatura

Toothing data

	Dati della coppia vite-corona Worm wheel data	Rapporto / Ratio											
		5	7.5	10	15	20	25	30	40	50	60	80	100
CM026	Z	6	4	3	2	2		1	1	1	1		
	β	34° 35'	24° 41'	19° 1'	12° 57'	10° 30'		6° 33'	5° 17'	4° 26'	3° 49'		
CM030	Z	6	4	3	2	2	2	1	1	1	1	1	1
	β	27° 4'	24° 28'	18° 50'	12° 49'	10° 23'	8° 43'	6° 29'	5° 14'	4° 23'	3° 46'	2° 57'	2° 25'
CM040	Z	6	4	3	2	2	2	1	1	1	1	1	1
	β	34° 19'	24° 28'	18° 50'	12° 49'	10° 23'	8° 43'	6° 29'	5° 14'	4° 23'	3° 46'	2° 57'	2° 25'

Rendimento

Efficiency

	n_1 [min ⁻¹]	Rendimento Efficiency	Rapporto / Ratio											
			5	7.5	10	15	20	25	30	40	50	60	80	100
CM026	2800	Rd	89	87	85	83	80		73	68	64	60		
	1400		87	84	83	78	74		66	61	57	53		
	900		84	83	80	75	71		61	57	52	48		
		Rs	72	71	68	61	56		46	41	36	34		
CM030	2800	Rd	89	88	86	84	81	78	74	70	65	62	57	52
	1400		86	85	84	79	75	72	67	62	58	55	48	43
	900		84	83	81	75	71	68	62	58	53	49	43	39
		Rs	72	67	63	55	50	43	39	35	31	27	23	21
CM040	2800	Rd	90	89	87	84	83	80	77	73	69	66	60	56
	1400		88	86	84	81	78	74	70	65	60	58	52	46
	900		86	84	82	77	74	70	66	60	57	53	46	41
		Rs	74	71	67	60	55	51	45	40	36	32	28	24



Rendimento teorico del riduttore dopo il rodaggio
Theoretical efficiency of the gearbox after the first running period



Dati tecnici per servizio S2

Technical data for S2 duty

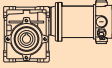
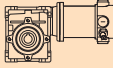
P_1 [W]	n_2 [min ⁻¹]	M_2 [Nm]	sf	i		Versione motore Motor version	P_1 [W]	n_2 [min ⁻¹]	M_2 [Nm]	sf	i		Versione motore Motor version
160							250						
(3000 min ⁻¹)	600	2	4.4	5	120/026	120/240	(3000 min ⁻¹)	600	4	2.8	5	180/026	120/240
	400	3	3.3	7.5	120/026			400	5	2.1	7.5	180/026	
	300	4	2.5	10	120/026			300	7	1.6	10	180/026	
	200	6	1.7	15	120/026			200	10	1.1	15	180/026	
	150	8	1.3	20	120/026			150	13	0.9	20	180/026	
	100	11	1.1	30	120/026			100	17	0.7	30	180/026	
	75	14	0.8	40	120/026			75	16	0.7	40	180/026	
	60	14	0.7	50	120/026			60	14	0.7	50	180/026	
	50	13	0.7	60	120/026			50	13	0.7	60	180/026	
	600	2	5.7	5	120/030	120/240		600	4	3.7	5	180/030	120/240
	400	3	4.5	7.5	120/030			400	5	2.9	7.5	180/030	
	300	4	3.7	10	120/030			300	7	2.3	10	180/030	
	200	6	2.5	15	120/030			200	10	1.6	15	180/030	
	150	8	1.7	20	120/030			150	13	1.1	20	180/030	
	120	10	1.5	25	120/030			120	16	1.0	25	180/030	
	100	11	1.6	30	120/030			100	18	1.0	30	180/030	
	75	14	1.1	40	120/030			75	22	0.7	40	180/030	
	60	17	0.9	50	120/030			60	21	0.7	50	180/030	
	50	20	0.7	60	120/030			50	20	0.7	60	180/030	
	38	17	0.7	80	120/030			38	17	0.7	80	180/030	
	30	16	0.7	100	120/030			30	16	0.7	100	180/030	
	150	8	3.7	20	120/040	120/240		600	4	8.1	5	180/040	120/240
	120	10	2.7	25	120/040			400	5	5.8	7.5	180/040	
	100	12	3.2	30	120/040			300	7	4.8	10	180/040	
	75	15	2.3	40	120/040			200	10	3.5	15	180/040	
	60	18	1.8	50	120/040			150	13	2.3	20	180/040	
	50	20	1.4	60	120/040			120	16	1.8	25	180/040	
	38	24	1.1	80	120/040			100	18	2.1	30	180/040	
	30	29	0.8	100	120/040			75	23	1.5	40	180/040	
								60	27	1.2	50	180/040	
								50	32	0.9	60	180/040	
								38	38	0.7	80	180/040	
								30	34	0.7	100	180/040	

N.B.
Verificare sempre che la coppia M_2 utilizzata non ecceda il valore indicato nelle caselle in grigio

N.B.
Please check that the output torque M_2 does not exceed the value in the grey areas

NOTA: per servizio continuo o altamente intermittente, contattare il servizio tecnico

NOTE: for continuous or highly intermittent duty, please contact our technical service

Motori applicabili

IEC Motor adapters

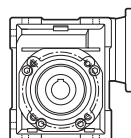
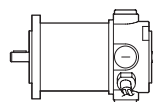

		ND	
		120.120 120.240	180.120 180.240
CM	026	5 - 60	5 - 60
	030	5 - 100	5 - 100
	040	5 - 100	5 - 100

5-100

Rapporti di riduzione i
Ratio i

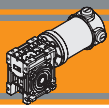

Dimensioni

Dimensions

NDCM120/026 U

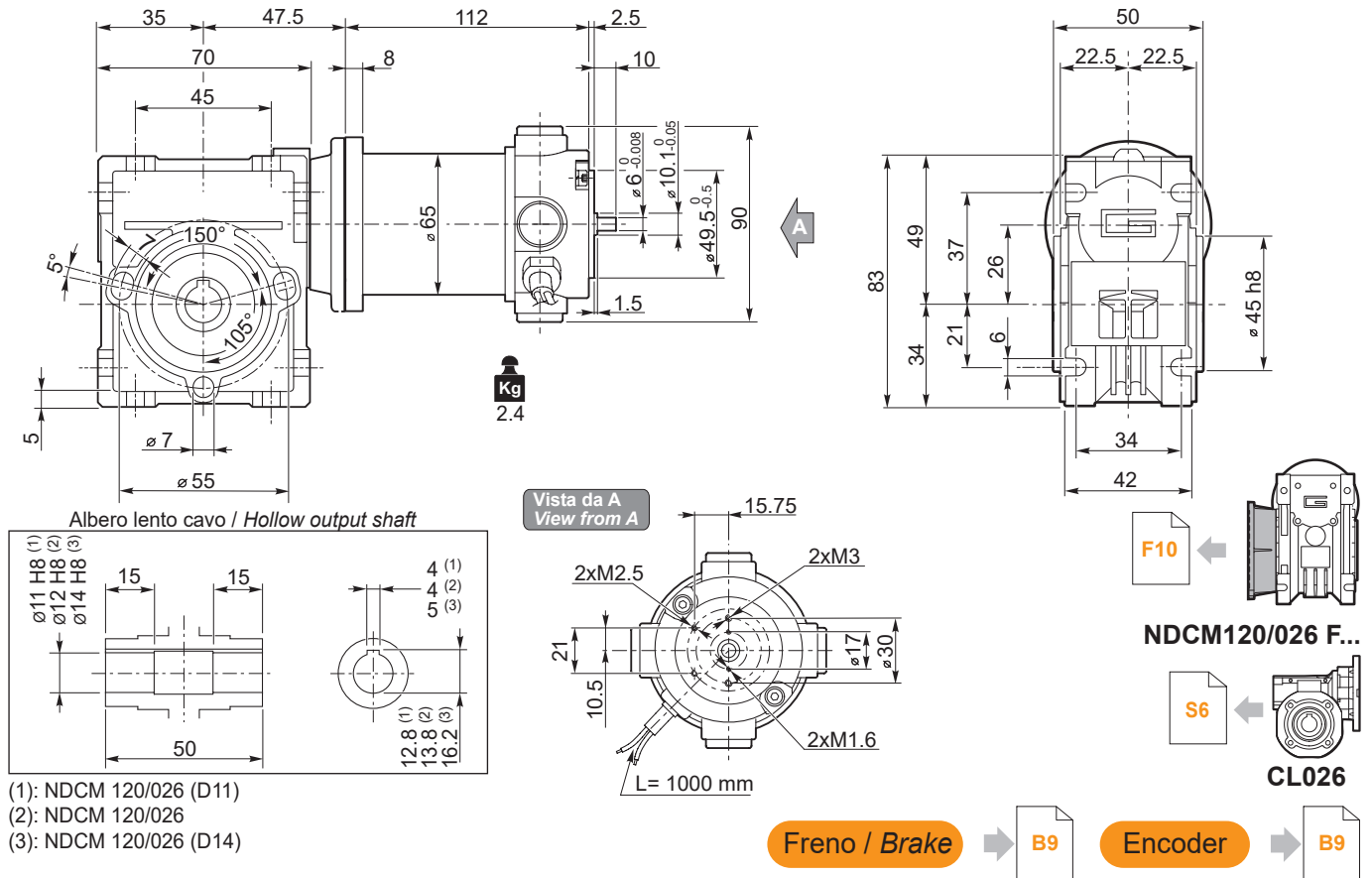

NDCM120/030 U

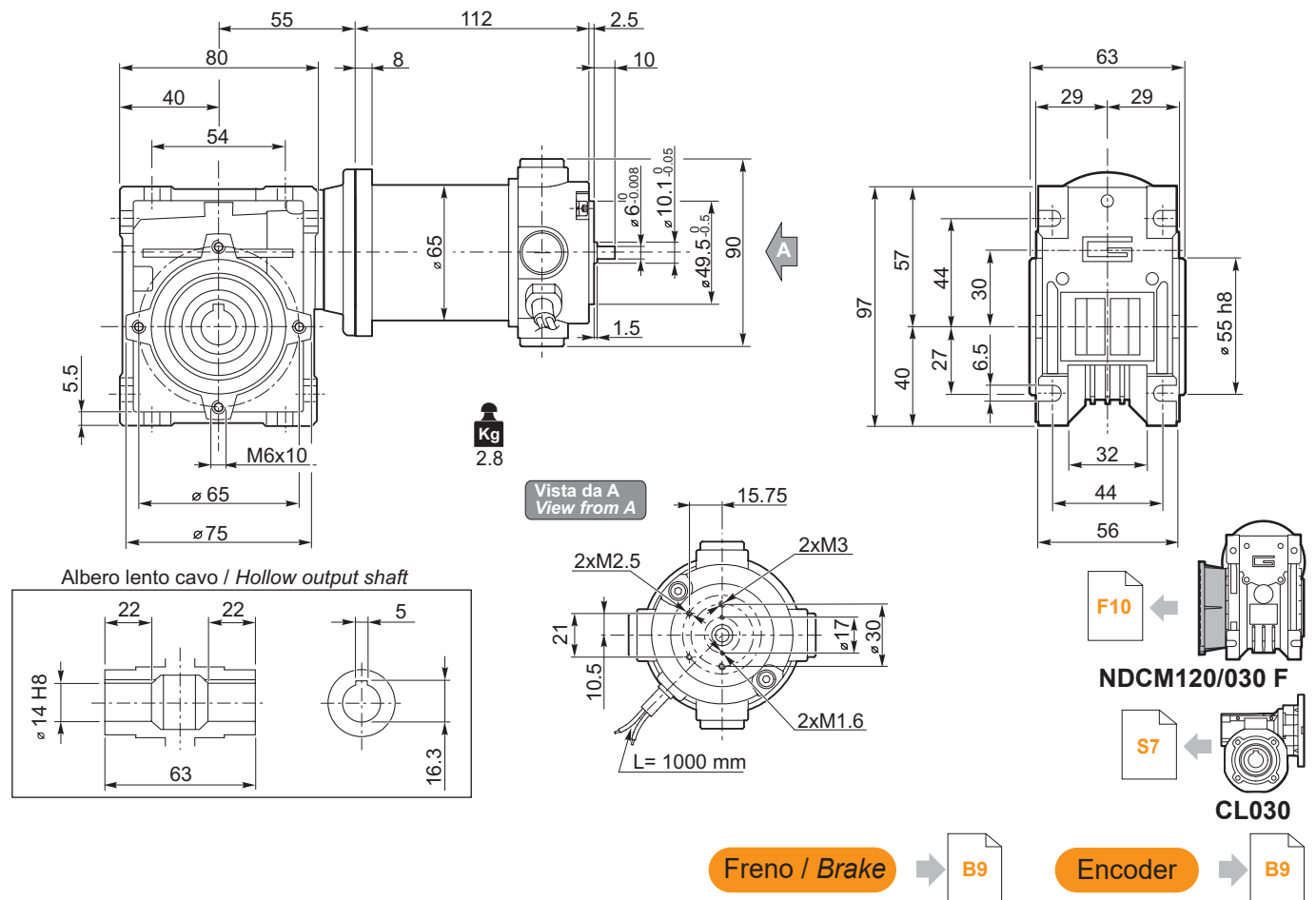

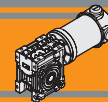

Dimensioni

Dimensions

NDCM120/040 U

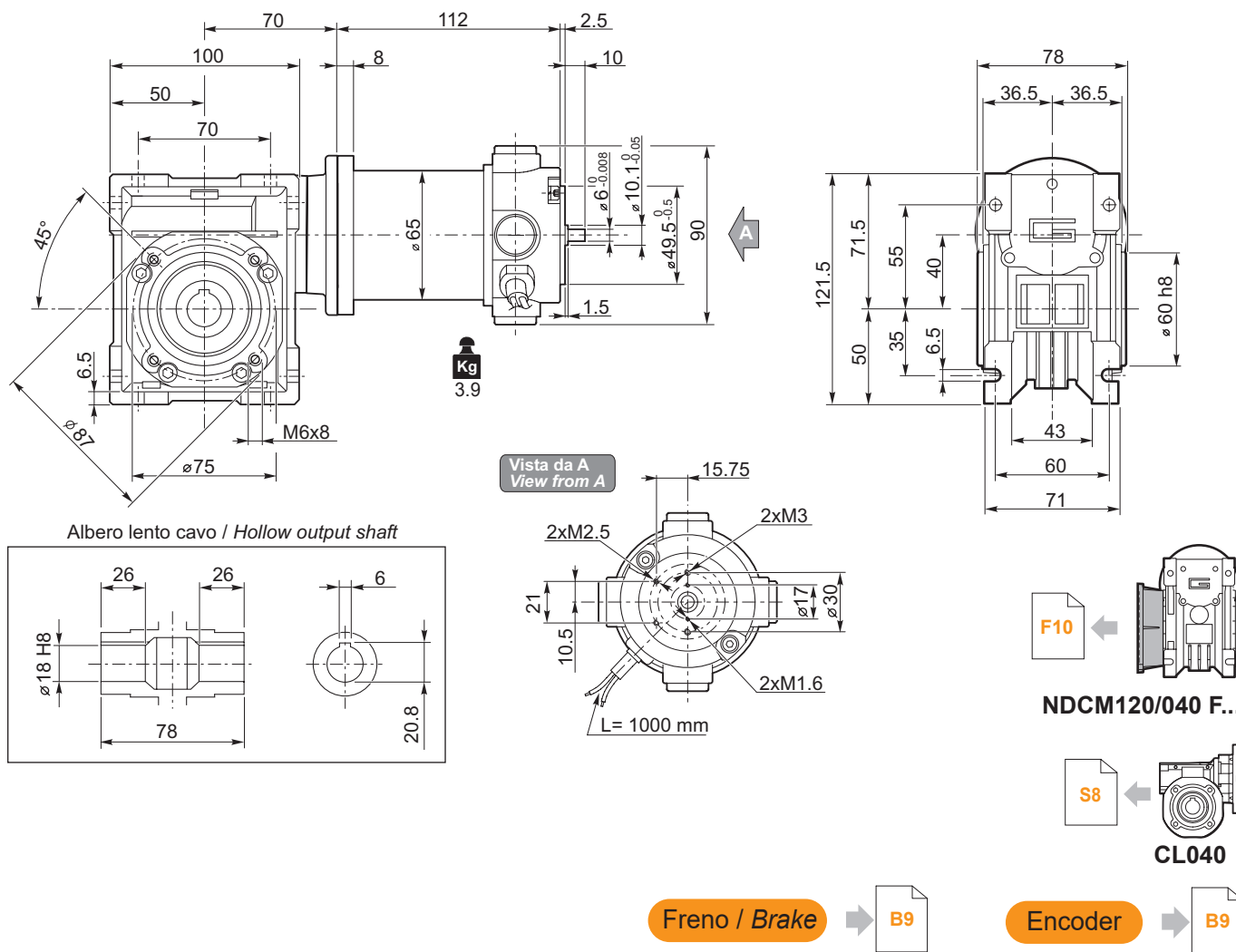

NDCM

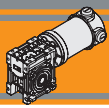

Dimensioni

Dimensions

NDCM180/026 U

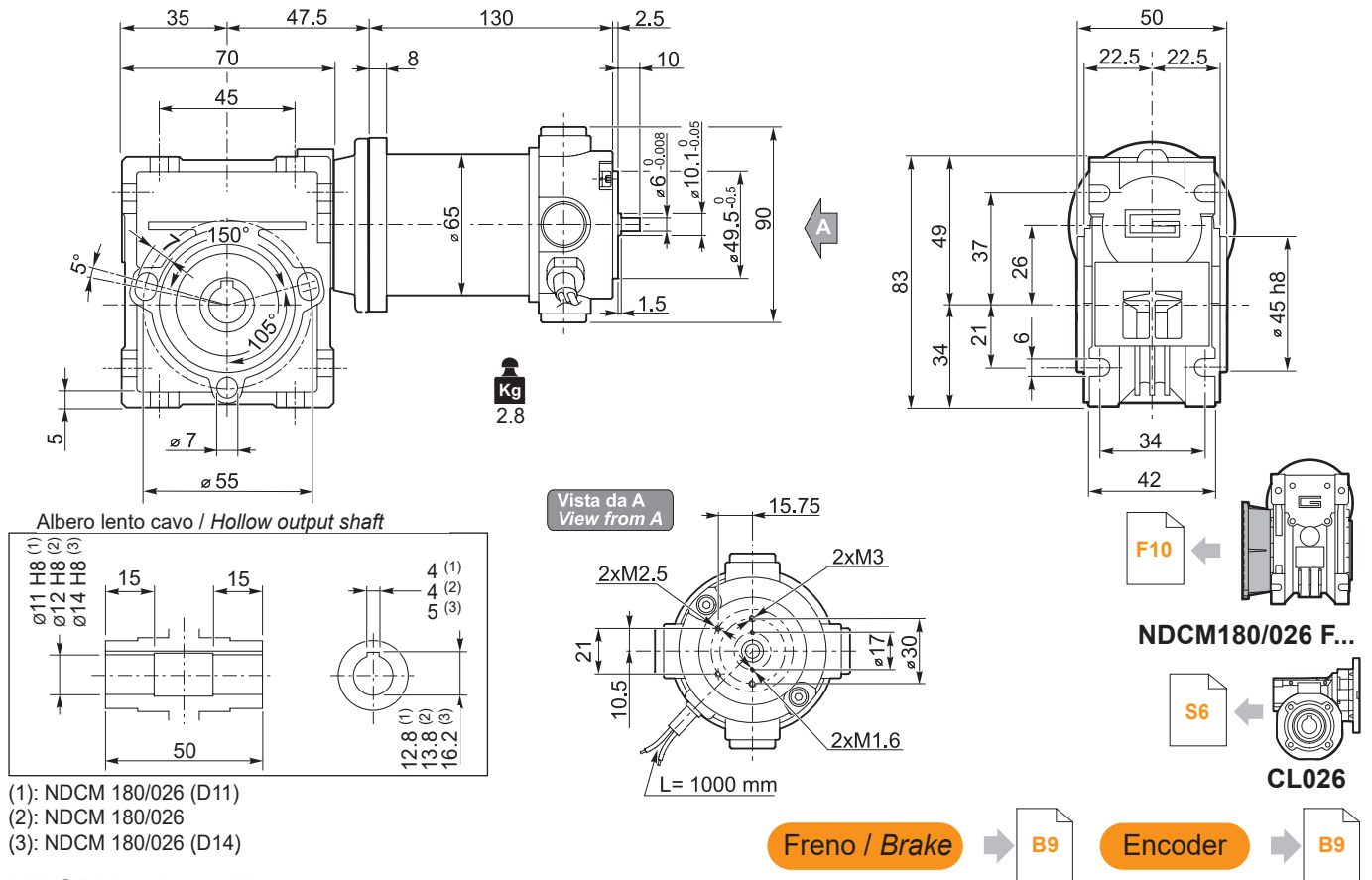

NDCM180/030 U

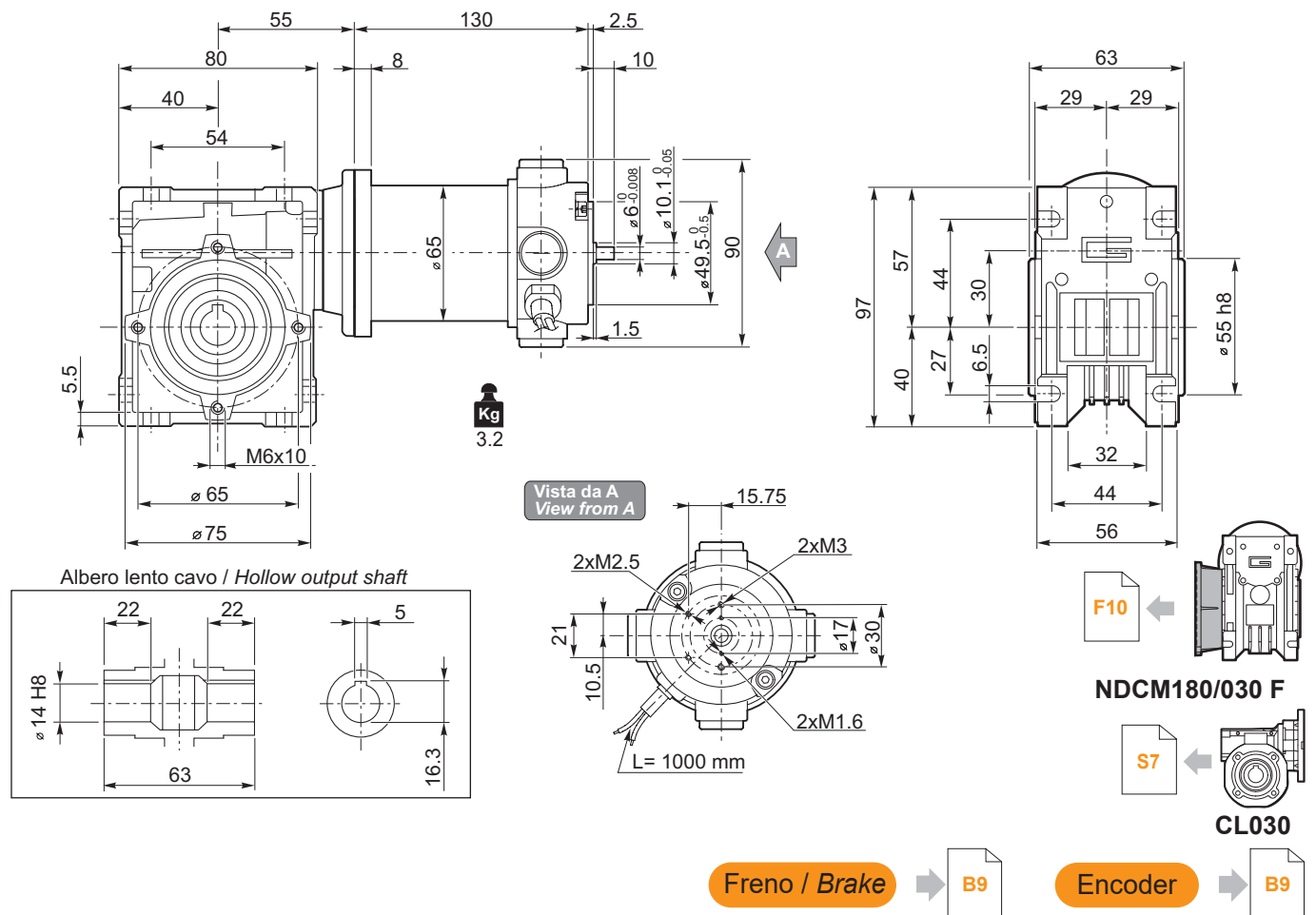



Dimensioni

Dimensions

NDCM180/040 U

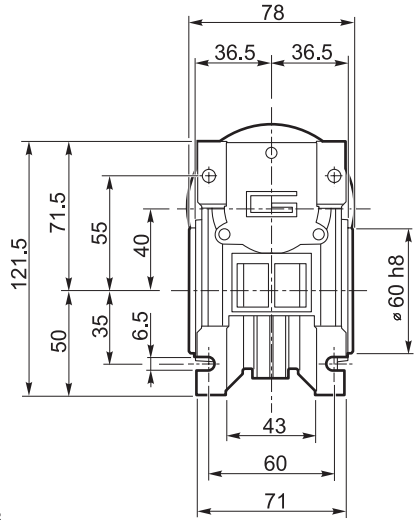
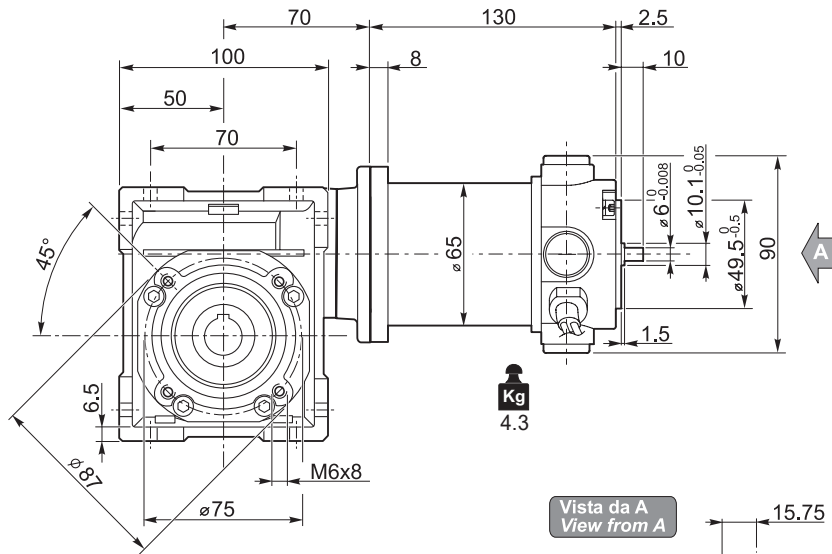

Albero lento cavo / Hollow output shaft

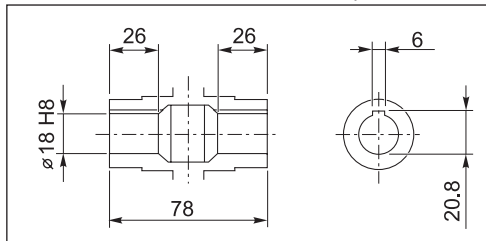

Vista da A
View from A

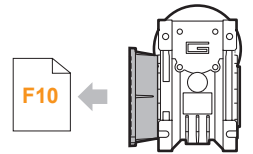
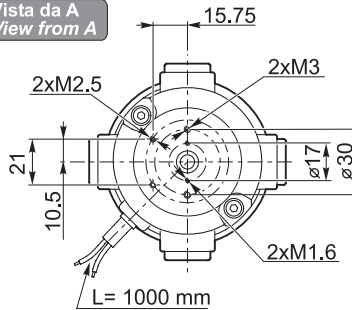

NDCM180/040 F...

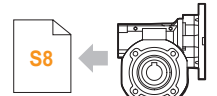

CL040

Freno / Brake



Encoder



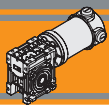

Dimensioni

Dimensions

NDCM.../... F... Flange uscita / Output flanges

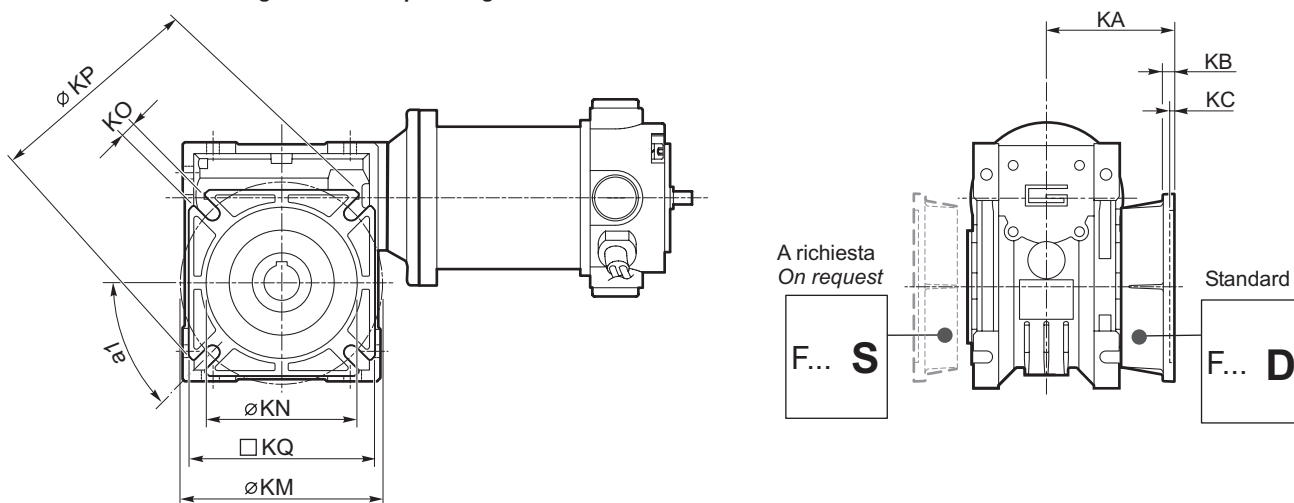

	CM..F							CM..F28							CM..F30											
	a1	KA	KB	KC	KM	KN _{H8}	KO	KP	KQ	KA	KB	KC	KM	KN _{H8}	KO	KP	KQ	KA	KB	KC	KM	KN _{H8}	KO	KP	KQ	
026 (D11)																										
026	45°	45	6	4.5	55-69	40	6.5(n.4)	75	70	44	6.5	5	56-64	40	6.5	70	60	48	6.5	5	68	50	6.5	80	70	
026 (D14)																										

	CM..F							CM..FB							CM..FL										
	a1	KA	KB	KC	KM	KN _{H8}	KO	KP	KQ	KA	KB	KC	KM	KN _{H8}	KO	KP	KQ	KA	KB	KC	KM	KN _{H8}	KO	KP	KQ
030	45°	54.5	6	4	68	50	6.5(n.4)	80	70	—	—	—	—	—	—	—	—	—	—	—	—	—	—	—	—
040	45°	67	7.5	4.5	80-95	60	9(n.4)	110	95	80	8.5	5	115-125	95	9.5(n.4)	140	112	97	7.5	4.5	80-95	60	10(n.4)	110	95

Opzioni

Options

VS - Vite sporgente / Extended input shaft

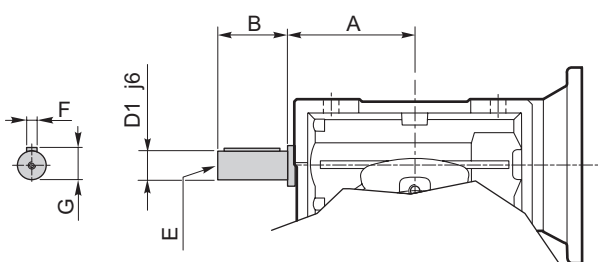

	A	B	D ₁ j6	E	F	G
CM 030	45	20	9	M4	3	10.2
CM 040	53	23	11	M5	4	12.5

Costruito su richiesta
Built on request

SC - Safety cover

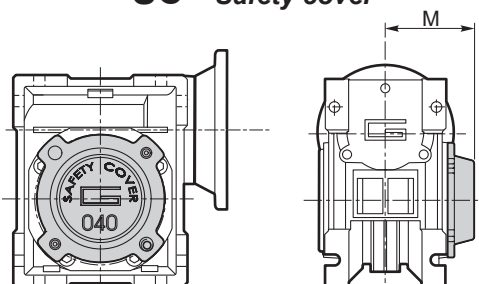

	M
CM 030	47
CM 040	54.5

WD - Washdown cover

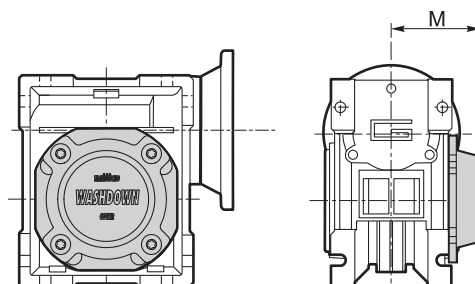

CM	M
030	48
040	55.5



Accessori

Accessories

Albero lento

Output shaft

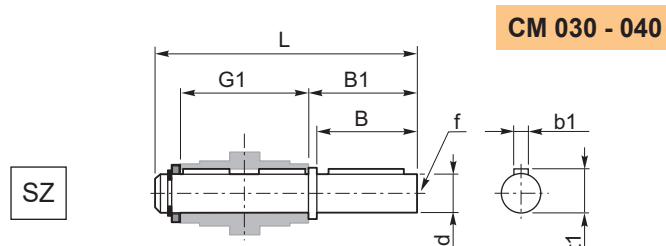
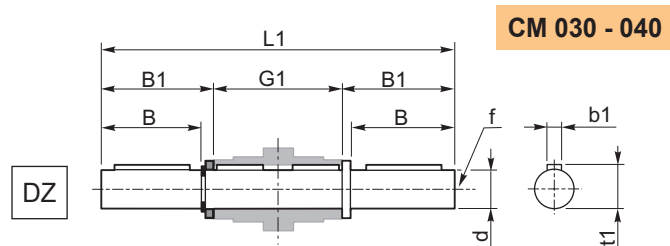

	d h7	B	B1	G1	L	L1	f	b1	t1
CM 030	14	30	32.5	63	102	128	M6	5	16
CM 040	18	40	43	78	128	164	M6	6	20.5

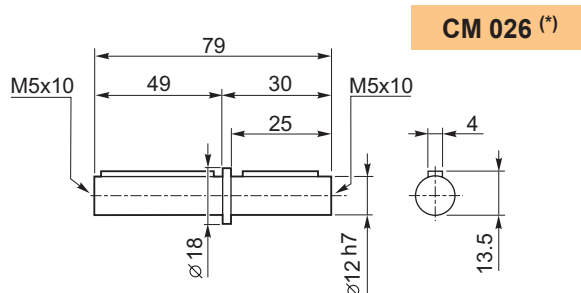

(*)
Nota: disponibile solo per cavo uscita Ø12
Note: available for output hollow shaft Ø12 only

Braccio di reazione

Torque arm

	K1	G	KG	KH	R
CM 030	85	14	23	8	15
CM 040	100	14	31	10	18

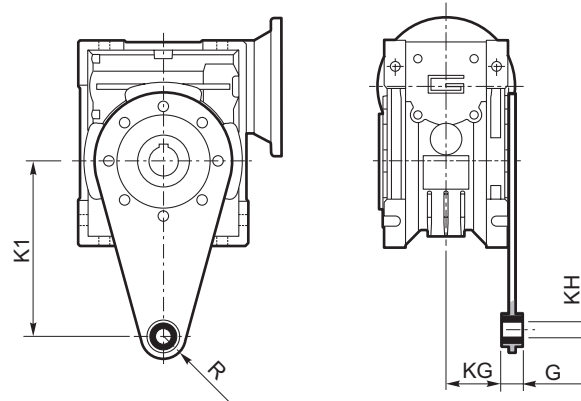

NDCM

 **TRANSTECNO SRL
HEADQUARTERS**

Company subject to the management
and coordination of INTERPUMP GROUP SPA
Via Caduti di Sabbiano, 11/D-E
40011 Anzola dell'Emilia (BO)
ITALY
T+39 051 64 25 811
F +39 051 73 49 43
sales@transtecno.com
www.transtecno.com

**TRANSTECNO**[®]
the modular gearmotor

CATDCALU0624

MEMBER OF INTERPUMP GROUP



 **HANGZHOU INTERPUMP
POWER TRANSMISSIONS CO LTD**
No.4 Xiuyan Road Fengdu Industry Zone
Pingyao Town Yuhang District
Hangzhou City, Zhejiang Province
311115 – CHINA
T +86 571 86 92 02 60
info-china@transtecno.cn
www.transtecno.cn

 **TRANSTECNO IBÉRICA
THE MODULAR GEARMOTOR, S.A.**
Carrer de la Ciència, 45
08840 Viladecans (Barcelona) - SPAIN
T +34 931 598 950
info@transtecno.es
www.transtecno.es

 **TRANSTECNO B.V.**
Siliciumweg 32
3812 SX Amersfoort – NETHERLANDS
T +31(0) 33 45 19 505
info@transtecno.nl
www.transtecno.nl

 **TRANSTECNO AANDRIJFTECHNIEK B.V.**
Siliciumweg 32
3812 SX Amersfoort – NETHERLANDS
T +31 (0) 33 20 4 7 006
info@transtecnoaandrijftechnik.nl
www.transtecnoaandrijftechnik.nl

 **MA TRANSTECNO S.A.P.I. DE C.V.**
Av. Mundial # 176, Parque Industrial
JM Apodaca, Nuevo León,
C.P. 66633 - MÉXICO
T +52 8113340920
info@transtecno.com.mx
www.transtecno.com.mx

 **TRANSTECNO USA**
8 Creek Parkway,
Boothwyn PA 19061-8136 - UNITED STATES
T +1 (610) 4970154

TRANSTECNO USA – WEST COAST BRANCH
14561 Frylands Blvd SE
Monroe, WA 98272 - UNITED STATES
T +1 360-863-1300
usaoffice@transtecno.com
www.transtecno.com

 **TRANSTECNO CANADA**
51 B Caldari Road Unit 10
Vaughan, ON L4K 4G3 - CANADA
T +1 905 761 0762
canadaoffice@transtecno.com
www.transtecno.com

 **TRANSTECNO INDIA**
#6A, Sipcot Industrial complex, Phase-1,Elasagiri Road
Hosur – 635126 Tamilnadu - INDIA
T +91 4344 274434
M +91 81443 88800

TRANSTECNO INDIA – NORTH BRANCH
Plot No: 3 A, Sector 2, IIE, Sidcul, Pantnagar
U.S. Nagar, Uttarakhand – 263153 - INDIA
indiaoffice@transtecno.com
www.transtecno.com

 **TRANSTECNO BRAZIL**
Rua Gilberto de Zorzi, 525 Forqueta - CEP. 95115-730
CX Postal 3544 Caxias do Sul RS – BRAZIL

TRANSTECNO BRAZIL – SÃO PAULO BRANCH
R. Mafalda Barnabe Soliane, 314 – CEP. 13347-610
Indaiatuba, São Paulo - BRAZIL
T +55 19 3437 2520

TRANSTECNO BRAZIL – PORTO ALEGRE BRANCH
Rua Dr. Freire Alemão 155 / 402 - CEP. 90450-060
Auxiliadora Porto Alegre RS - BRAZIL
T +55 51 3251 5447
M +55 51 811 45 962
braziloffice@transtecno.com
www.transtecno.com.br

 **INTERPUMP ANTRIEBSTECHNIK GMBH**
Büro Stuttgart - GERMANY
T +49 (0)171 4781909
germanoffice@transtecno.com
www.transtecno.com

 **SALES OFFICE OCEANIA**
Unit 5, 12 Nyholt Drive, Yatala 4207
Queensland - AUSTRALIA
T +61 07 3800 0103
M +61 04 38060997

 **UNIT 9, 94 Boundary Rd, Sunshine West 3020
Victoria - AUSTRALIA
T +61 9312 4722
oceaniaoffice@transtecno.com
www.transtecno.com.au**