

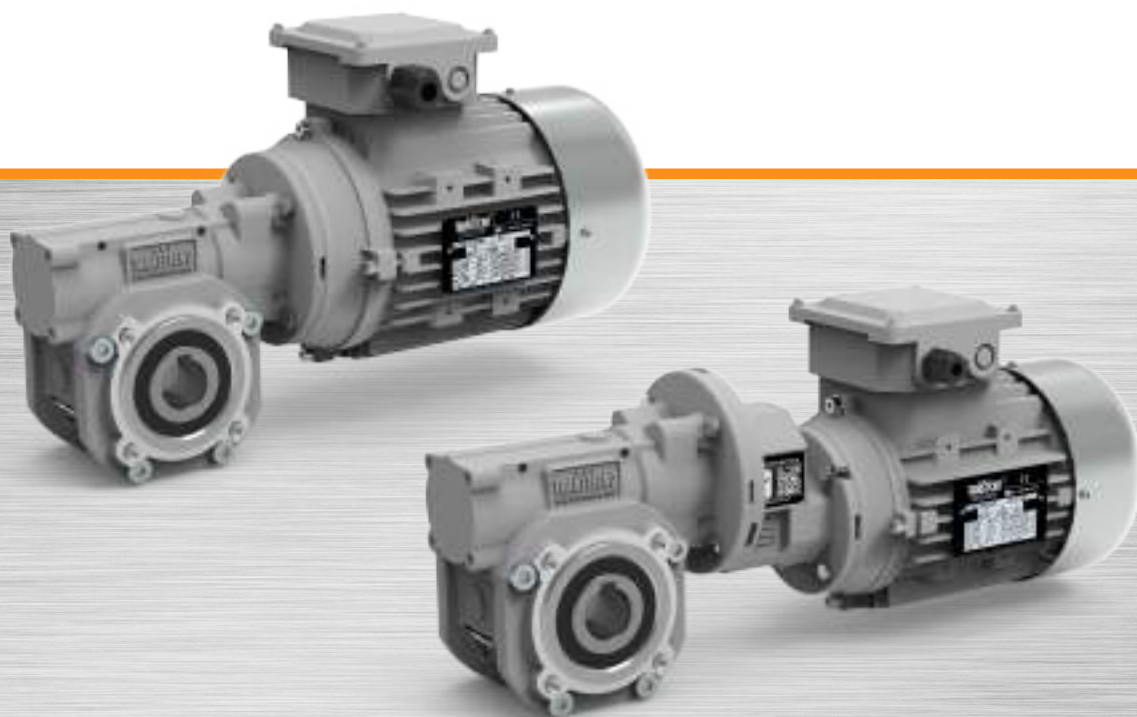

蜗轮蜗杆减速电机 Wormgearmotors

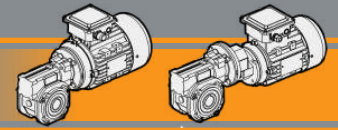



索引	<i>Index</i>	页码 <i>Page</i>
技术特征	<i>Technical features</i>	G2
选型	<i>Classification</i>	G2
安装位置	<i>Direction of rotation</i>	G4
代号说明	<i>Symbols</i>	G4
润滑油	<i>Lubrication</i>	G4
径向负荷	<i>Radial loads</i>	G5
齿面数据	<i>Toothing data</i>	G5
效率	<i>Efficiency</i>	G6
技术参数	<i>Technical data</i>	G6
IEC电机适配法兰	<i>IEC Motor adapters</i>	G12
尺寸参数	<i>Dimensions</i>	G14
附件	<i>Accessories</i>	G21
可选项	<i>Options</i>	G22

该目录为最新版本，可替代以往的任何版本及修订。如果您是通过非正式渠道取得，不能保证是最新内容，可在本公司网站上查阅 www.transtecno.com

This section replaces any previous edition and revision. If you obtained this catalogue other than through controlled distribution channels, the most up to date content is not guaranteed. In this case the latest version is available on our web site www.transtecno.com

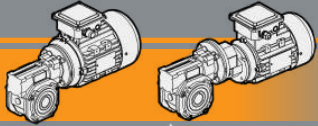

CL / CLP 蜗轮蜗杆减速电机 Wormgearmotors

技术特征

Technical features

高度模块化是CL和CLP蜗轮蜗杆减速电机系列的设计特点，这得益于输入和输出套件的广泛选择。

The high degree of modularity is a design feature of CL and CLP wormgearmotors range thanks to a wide selection of input and output kits.

CL和CLP系列的主要特点是：

Main features of CL and CLP range are:

- 026, 030, 040, 050, 070 型号均使用压铸铝合金箱体；
- 前置级使用压铸铝合金箱体；

- Die-cast aluminium housing on sizes 026, 030, 040, 050, and 070;
- Die-cast aluminium housing on pre-stage units;

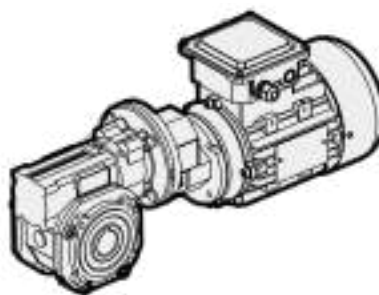
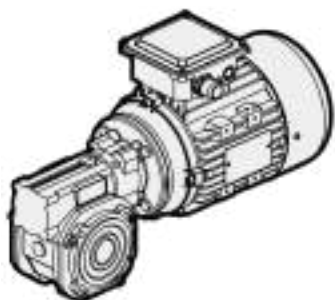

选型

Classification

蜗轮蜗杆减速机 / WORMGEARBOXES

减速机 / GEARBOX									
CL	030	U	10	63	B14	SZDX	BRSX	90	VS
类型 Type	型号 Size	底座/输出法兰型号 Gearbox Version	速比 Ratio	IEC 	法兰型号 Version	输出轴 Output shaft	扭力臂 Torque arm	角度 Angle	可选项 Options
CL 	026 030 040 050 070	U F...	Vedere tabella See tables	56.. — 112..	B5 B14	SZDX SZSX DZ	BRDX BRSX *	0° 90° 180° 270°	VS
CLIS 									

前置蜗轮蜗杆减速机组合 / PRE-STAGE WORMGEARBOXES

减速机 / GEARBOX											
CLP	063/050	U	90	63	B14	SZDX	BRSX	90	P4	M1	VS
类型 Type	型号 Size	底座/输出法兰型号 Gearbox Version	速比 Ratio	IEC 	法兰型号 Version	输出轴 Output shaft	扭力臂 Torque arm	角度 Angle	前置级 安装位置 Pre stage mounting position	安装位置 Mounting position	可选项 Options
CLP 	056/030 056/040 063/040 063/050 071/050 071/070 080/070 090/070	U F...	见表格 See tables	56.. — 90..	B5 B14	SZDX SZSX DZ	BRDX BRSX *	0° 90° 180° 270°	P1 P2 P3 (标准) P4	M1 (B3) M2 (V6) M3 (B8) M4 (V5) M6 (B6) M5 (B7)	VS

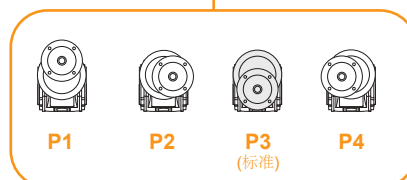

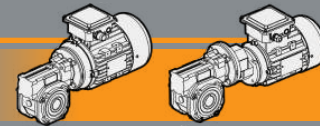

选型

Classification

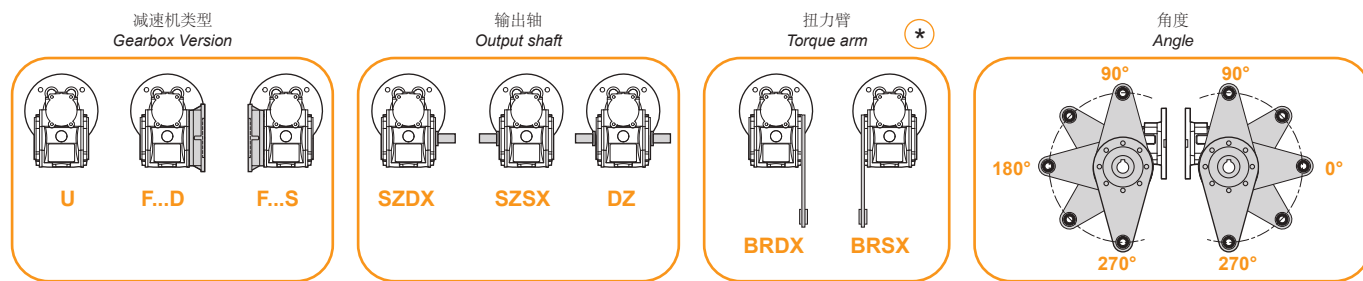

* 注释：扭力臂将不组装。
NOTE: the torque arm will be supplied not assembled.

三相电机 / THREE PHASE MOTOR

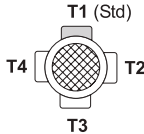
TS	63	2	4	0.18 kW	B5	3 ph	230-400 V	50 Hz	T1
类型 Type	型号 Size	功率系数 Power coefficient	极 Poles	功率 Power	法兰型号 Version	相 Phases	电压 Voltage	频率 Frequency	接线盒位置 Terminal box pos.
TS	 K1 页	1-2-3-S L1-L2	4	0.09 kW ... 2.2 kW	B5 B14	3 ph	230-400 V 275-480 V	50Hz 60Hz	

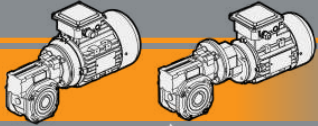

CL / CLP 蜗轮蜗杆减速电机 Wormgearmotors

运转方向

Direction of rotation

CL

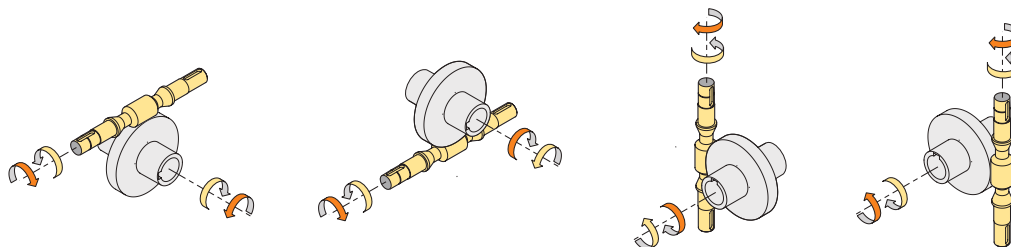

CLP

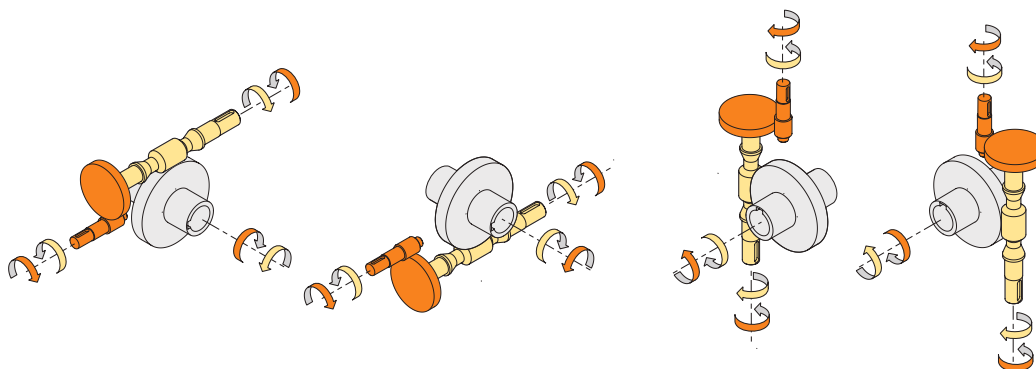

代号说明

Symbols

n_1	[min ⁻¹]	输入转速 / <i>Input speed</i>	sf	服务系数 / <i>Service factor</i>
n_2	[min ⁻¹]	输出转速 / <i>Output speed</i>	Rd	动态效率 / <i>Dynamic efficiency</i>
i		速比 / <i>Ratio</i>	Rs	静态效率 / <i>Static efficiency</i>
P_1	[kW]	输入功率 / <i>Input power</i>	R_2	输出端许用径向负荷 / <i>Permitted output radial load</i>
M_2	[Nm]	输出扭矩参照 P_1 / <i>Output torque referred to P_1</i>	A_2	输出端许用轴向负荷 / <i>Permitted output axial load</i>
P_{n1}	[kW]	额定输入功率 / <i>Nominal input power</i>	Z	蜗杆头数 / <i>Worm starts</i>
M_{n2}	[Nm]	额定输出扭矩参照 P_{n1} / <i>Nominal output torque referred to P_{n1}</i>	β	螺旋角 / <i>Helix angle</i>
 kg	[kg]	减速机重量 / <i>Weight of the gearbox only</i>		

润滑油

Lubrication

减速机使用长寿命人工合成润滑油（粘度320），因为这个原因可以在任意位置安装，并免维护。

Permanent synthetic oil long-life lubrication (viscosity grade 320) makes it possible to use the gearmotors in all mounting positions; for this reason they can be installed in any assembly position and do not require maintenance.

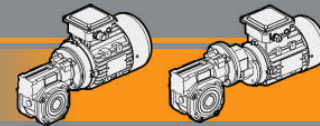

径向负荷

Radial loads

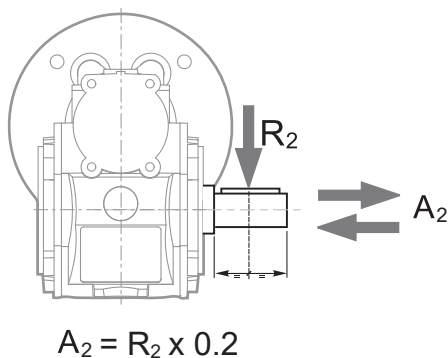

n_2 [min ⁻¹]	R_2 [N]				
	CL026	CL030	CL040	CL050	CL070
187	400	674	1264	1770	2613
140	490	743	1392	1949	2878
93	580	851	1596	2234	3298
70	610	936	1754	2456	3626
56	610	1008	1890	2646	3906
47	610	1069	2004	2805	4141
35	610	1179	2210	3095	4568
28	610	1270	2381	3334	4921
23	610	1356	2542	3559	5254
18	610	1471	2759	3862	5702
14	610	1600	3000	4200	6200
	CLP... /030	CLP... /040	CLP... /050	CLP... /070	

当产生的径向负荷不是作用在传动轴伸出长度的中间位置，必须用以下公式来计算有效负荷：

When the resulting radial load is not applied on the centre line of the shaft it is necessary to calculate the effective load with the following formula:

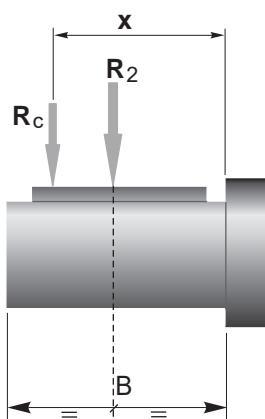

	CL	CL / CLP			
	026	030	040	050	070
a	56	65	84	101	122
b	43	50	64	76	92
R_{2MAX}	610	1600	3000	4200	6200

$$R_c = \frac{R_2 \cdot a}{(b+x)} \leq R_{2MAX}$$

$$R \leq R_c$$

a, b = 图表中给出的值
a, b = values given in the table

CL/CLP

齿面参数

Toothing data

	蜗杆参数 Worm wheel data	速比 / Ratio											
		5	7.5	10	15	20	25	30	40	50	60	80	100
CL026	Z	6	4	3	2	2		1	1	1	1		
	β	34° 35'	24° 41'	19° 1'	12° 57'	10° 30'		6° 33'	5° 17'	4° 26'	3° 49'		
CL030	Z	6	4	3	2	2	2	1	1	1	1	1	1
	β	27° 4'	24° 28'	18° 50'	12° 49'	10° 23'	8° 43'	6° 29'	5° 14'	4° 23'	3° 46'	2° 57'	2° 25'
CL040	Z	6	4	3	2	2	2	1	1	1	1	1	1
	β	34° 19'	24° 28'	18° 50'	12° 49'	10° 23'	8° 43'	6° 29'	5° 14'	4° 23'	3° 46'	2° 57'	2° 25'
CL050	Z	6	4	3	2	2	2	1	1	1	1	1	1
	β	33° 37'	23° 54'	18° 23'	12° 29'	10° 6'	8° 28'	6° 19'	5° 5'	4° 15'	3° 39'	2° 51'	2° 20'
CL070	Z		4	3	2	2	2	1	1	1	1	1	1
	β		26° 12'	20° 15'	13° 49'	11° 15'	9° 29'	7° 0'	5° 41'	4° 46'	4° 7'	3° 13'	2° 39'

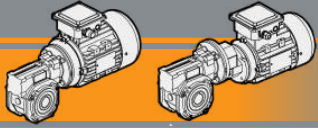

CL / CLP 蜗轮蜗杆减速电机

Wormgearmotors

效率

Efficiency

	n ₁ [min ⁻¹]	效率 Efficiency	速比 / Ratio											
			5	7.5	10	15	20	25	30	40	50	60	80	100
CL026	2800	Rd	89	87	85	83	80		73	68	64	60		
	1400		87	84	83	78	74		66	61	57	53		
	900		84	83	80	75	71		61	57	52	48		
		Rs	72	71	68	61	56	46	41	36	34			
CL030	2800	Rd	89	88	86	84	81	78	74	70	65	62	57	52
	1400		86	85	84	79	75	72	67	62	58	55	48	43
	900		84	83	81	75	71	68	62	58	53	49	43	39
		Rs	72	67	63	55	50	43	39	35	31	27	23	21
CL040	2800	Rd	90	89	87	84	83	80	77	73	69	66	60	56
	1400		88	86	84	81	78	74	70	65	60	58	52	46
	900		86	84	82	77	74	70	66	60	57	53	46	41
		Rs	74	71	67	60	55	51	45	40	36	32	28	24
CL050	2800	Rd	91	90	88	86	84	82	78	74	71	68	62	58
	1400		89	87	85	82	79	76	72	67	63	60	54	49
	900		87	85	84	79	75	72	68	62	59	55	48	43
		Rs	73	70	66	59	55	51	44	39	35	32	27	23
CL070	2800	Rd		90	89	87	85	84	80	77	74	72	67	62
	1400			89	87	84	82	80	76	72	68	65	60	53
	900			87	85	82	79	77	72	67	63	60	54	49
		Rs		72	69	62	60	55	48	43	38	36	31	26



减速机的理论效率是在第一个运转周期之后

Theoretical efficiency of the gearbox after the first running period

技术参数

n₁ 1400 min⁻¹

Technical data

	n ₂ [min ⁻¹]	Mn ₂ [Nm]	Pn ₁ [kW]	i
---	--	-------------------------	-------------------------	---

	n ₂ [min ⁻¹]	Mn ₂ [Nm]	Pn ₁ [kW]	i
---	--	-------------------------	-------------------------	---

CLIS026

280	13	0.44	5
187	14	0.33	7.5
140	14	0.25	10
93	14	0.18	15
70	14	0.14	20
47	15	0.11	30
35	14	0.08	40
28	13	0.07	50
23	12	0.06	60

CLIS050

280	75	2.5	5
187	79	1.8	7.5
140	82	1.4	10
93	82	0.98	15
70	72	0.67	20
56	70	0.54	25
47	88	0.60	30
35	76	0.42	40
28	72	0.34	50
23	69	0.28	60
18	60	0.20	80
14	56	0.17	100

CLIS030

280	18	0.61	5
187	20	0.46	7.5
140	21	0.37	10
93	21	0.26	15
70	19	0.19	20
56	20	0.16	25
47	22	0.16	30
35	20	0.12	40
28	19	0.10	50
23	17	0.08	60
18	15	0.06	80
14	14	0.05	100

CLIS070

187	200	4.4	7.5
140	218	3.7	10
93	221	2.6	15
70	202	1.8	20
56	180	1.3	25
47	241	1.6	30
35	210	1.1	40
28	190	0.82	50
23	181	0.68	60
18	159	0.49	80
14	154	0.43	100

CLIS040

280	41	1.37	5
187	44	1.00	7.5
140	45	0.79	10
93	45	0.54	15
70	40	0.38	20
56	38	0.30	25
47	48	0.34	30
35	42	0.24	40
28	39	0.19	50
23	36	0.15	60
18	33	0.12	80
14	31	0.10	100

注释: Pn₁ 表示机械的输入功率, 由于温度等因素会有所减低。更多详情请联系我们的技术部。

Note:

Pn₁ is an input mechanical power which must be reduced by the heating factor in order to get the relevant one. For more details please contact our Technical Service.

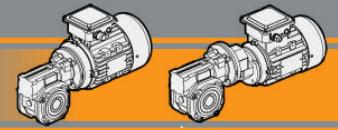

技术参数

Technical data

P_1 [kW]	n_2 [min ⁻¹]	M_2 [Nm]	sf	i					P_1 [kW]	n_2 [min ⁻¹]	M_2 [Nm]	sf	i				
0.06 - IEC 56									0.09 - IEC 56								
TS5614									TS5624 (1400 min ⁻¹)								
280	1.8	7.3	5	CL026				B14	280	2.7	4.9	5	CL026				B14
187	2.6	5.4	7.5	CL026				B14	187	3.9	3.6	7.5	CL026				B14
140	3.4	4.1	10	CL026				B14	140	5.1	2.7	10	CL026				B14
93	4.8	2.9	15	CL026				B14	93	7.2	1.9	15	CL026				B14
70	6.1	2.3	20	CL026				B14	70	9.1	1.5	20	CL026				B14
47	8.1	1.9	30	CL026				B14	47	12	1.2	30	CL026				B14
35	10	1.4	40	CL026				B14	35	15	0.9	40	CL026				B14
28	12	1.1	50	CL026				B14									
23	13	0.9	60	CL026				B14	280	2.6	6.8	5	CL030				B5/B14
									187	3.9	5.1	7.5	CL030				B5/B14
280	1.8	10.2	5	CL030				B14	140	5.2	4.1	10	CL030				B5/B14
187	2.6	7.7	7.5	CL030				B14	93	7.3	2.9	15	CL030				B5/B14
140	3.4	6.1	10	CL030				B14	70	9.2	2.1	20	CL030				B5/B14
93	4.9	4.3	15	CL030				B14	56	11	1.8	25	CL030				B5/B14
70	6.1	3.1	20	CL030				B14	47	12	1.8	30	CL030				B5/B14
56	7.4	2.7	25	CL030				B14	35	15	1.3	40	CL030				B5/B14
47	8.2	2.7	30	CL030				B14	28	18	1.1	50	CL030				B5/B14
35	10	2.0	40	CL030				B14	23	20	0.8	60	CL030				B5/B14
28	12	1.6	50	CL030				B14									
23	14	1.3	60	CL030				B14	23	24	1.1	60		CLP056/030			B14
23	16	1.6	60		CLP056/030			B14	19	29	0.9	75		CLP056/030			B14
19	19	1.4	75		CLP056/030			B14	16	32	1.0	90		CLP056/030			B14
18	16	1.0	80	CL030				B14	12	38	0.8	120		CLP056/030			B14
16	21	1.6	90		CLP056/030			B14									
14	18	0.8	100	CL030				B14	35	16	2.6	40	CL040				B5/B14
12	25	1.1	120		CLP056/030			B14	28	18	2.1	50	CL040				B5/B14
9	29	0.9	150		CLP056/030			B14	23	21	1.7	60	CL040				B5/B14
									23	25	2.3	60		CLP056/040			B14
28	12	3.2	50	CL040				B14	19	30	1.7	75		CLP056/040			B14
23	14	2.5	60	CL040				B14	18	26	1.3	80	CL040				B5/B14
23	17	3.4	60		CLP056/040			B14	16	34	2.1	90		CLP056/040			B14
19	20	2.6	75		CLP056/040			B14	14	28	1.1	100	CL040				B5/B14
18	17	1.9	80	CL040				B14	12	42	1.5	120		CLP056/040			B14
16	23	3.1	90		CLP056/040			B14	9	48	1.2	150		CLP056/040			B14
14	19	1.6	100	CL040				B14	8	53	1.0	180		CLP056/040			B14
12	28	2.2	120		CLP056/040			B14	5.8	62	0.8	240		CLP056/040			B14
9	32	1.8	150		CLP056/040			B14									
8	35	1.5	180		CLP056/040			B14									
6	41	1.1	240		CLP056/040			B14									
5	46	0.9	300		CLP056/040			B14									

CL/CLP



电机 Motors	TS
	5614 5624
IEC	56 B5 / B14

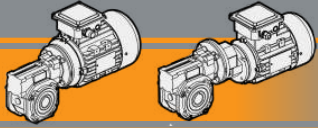

CL / CLP 蜗轮蜗杆减速电机 Wormgearmotors

技术参数

Technical data

P_1 [kW]	n_2 [min ⁻¹]	M_2 [Nm]	sf	i			P_1 [kW]	n_2 [min ⁻¹]	M_2 [Nm]	sf	i			P_1 [kW]	n_2 [min ⁻¹]	M_2 [Nm]	sf	i		
---------------	-------------------------------	---------------	----	---	--	--	---------------	-------------------------------	---------------	----	---	--	--	---------------	-------------------------------	---------------	----	---	--	--

0.12 - IEC 63

TS6314 (1400 min ⁻¹)	280	4	5.1	5	CL030		B5-B14
	187	5	3.8	7.5	CL030		B5-B14
	140	7	3.1	10	CL030		B5-B14
	93	10	2.2	15	CL030		B5-B14
	70	12	1.5	20	CL030		B5-B14
	56	15	1.4	25	CL030		B5-B14
	47	16	1.3	30	CL030		B5-B14
	35	20	1.0	40	CL030		B5-B14
	28	24	0.8	50	CL030		B5-B14
	280	4	11.4	5	CL040		B5-B14
	187	5	8.3	7.5	CL040		B5-B14
	140	7	6.5	10	CL040		B5-B14
93	10	4.5	15	CL040		B5-B14	
70	13	3.1	20	CL040		B5-B14	
56	15	2.5	25	CL040		B5-B14	
47	17	2.8	30	CL040		B5-B14	
35	21	2.0	40	CL040		B5-B14	
28	25	1.6	50	CL040		B5-B14	
23	28	1.3	60	CL040		B5-B14	
23	34	1.7	60		CLP063/040	B14	
19	40	1.3	75		CLP063/040	B14	
18	34	1.0	80	CL040		B5-B14	
16	45	1.6	90		CLP063/040	B14	
14	38	0.8	100	CL040		B5-B14	
12	56	1.1	120		CLP063/040	B14	
35	22	3.5	40	CL050		B5-B14	
28	26	2.8	50	CL050		B5-B14	
23	29	2.3	60	CL050		B5-B14	
23	34	3.0	60		CLP063/050	B14	
19	40	2.3	75		CLP063/050	B14	
18	35	1.7	80	CL050		B5-B14	
16	47	2.7	90		CLP063/050	B14	
14	40	1.4	100	CL050		B5-B14	
12	57	1.9	120		CLP063/050	B14	
9.3	66	1.6	150		CLP063/050	B14	
7.8	74	1.3	180		CLP063/050	B14	
5.8	85	1.0	240		CLP063/050	B14	

0.18 - IEC 63

TS6324 (1400 min ⁻¹)	280	5.4	7.6	5	CL040		B5/B14
	187	7.9	5.6	7.5	CL040		B5/B14
	140	10	4.4	10	CL040		B5/B14
	93	15	3.0	15	CL040		B5/B14
	70	19	2.1	20	CL040		B5/B14
	56	23	1.7	25	CL040		B5/B14
	47	26	1.9	30	CL040		B5/B14
	35	32	1.3	40	CL040		B5/B14
	28	37	1.1	50	CL040		B5/B14
	23	43	0.8	60	CL040		B5/B14
	23	51	1.1	60		CLP063/040	B14
	19	60	0.9	75		CLP063/040	B14
16	68	1.0	90		CLP063/040	B14	
35	33	2.3	40	CL050		B5/B14	
28	39	1.9	50	CL050		B5/B14	
23	44	1.6	60	CL050		B5/B14	
23	51	2.0	60		CLP063/050	B14	
19	60	1.5	75		CLP063/050	B14	
18	53	1.1	80	CL050		B5/B14	
16	70	1.8	90		CLP063/050	B14	
14	60	0.9	100	CL050		B5/B14	
12	85	1.3	120		CLP063/050	B14	
9.3	99	1.0	150		CLP063/050	B14	
7.8	110	0.9	180		CLP063/050	B14	

0.25 - IEC 63

TS6334 (1400 min ⁻¹)	280	7.3	2.5	5	CL030		B5/B14
	187	11	1.8	7.5	CL030		B5/B14
	140	14	1.5	10	CL030		B5/B14
	93	20	1.0	15	CL030		B5/B14
	280	7.5	5.5	5	CL040		B5/B14
	187	11	4.0	7.5	CL040		B5/B14
140	14	3.1	10	CL040		B5/B14	
93	21	2.2	15	CL040		B5/B14	
70	27	1.5	20	CL040		B5/B14	
56	32	1.2	25	CL040		B5/B14	
47	36	1.3	30	CL040		B5/B14	
35	44	0.9	40	CL040		B5/B14	
28	51	0.8	50	CL040		B5/B14	
56	32	2.2	25	CL050		B5/B14	
47	37	2.4	30	CL050		B5/B14	
35	46	1.7	40	CL050		B5/B14	
28	54	1.3	50	CL050		B5/B14	
23	61	1.1	60	CL050		B5/B14	
23	71	1.4	60		CLP063/050	B14	
19	84	1.1	75		CLP063/050	B14	
18	74	0.8	80	CL050		B5/B14	
16	98	1.3	90		CLP063/050	B14	

0.18 - IEC 63

TS6324 (1400 min ⁻¹)	280	5.3	3.4	5	CL030		B5/B14
	187	7.8	2.6	7.5	CL030		B5/B14
	140	10	2.0	10	CL030		B5/B14
	93	15	1.4	15	CL030		B5/B14
	70	18	1.0	20	CL030		B5/B14
	56	22	0.9	25	CL030		B5/B14
	47	25	0.9	30	CL030		B5/B14



电机 Motors	TS
	6314 6324 6334
IEC	63 B5 / B14

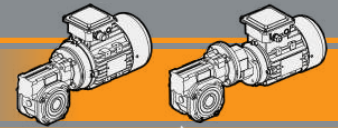

技术参数

Technical data

P_1 [kW]	n_2 [min ⁻¹]	M_2 [Nm]	sf	i					
0.25 - IEC 71									
TS7114 (1400 min ⁻¹)	280	8	5.5	5	CL040			B5-B14	
	187	11	4.0	7.5	CL040			B5-B14	
	140	14	3.1	10	CL040			B5-B14	
	93	21	2.2	15	CL040			B5-B14	
	70	27	1.5	20	CL040			B5-B14	
	56	32	1.2	25	CL040			B5-B14	
	47	36	1.3	30	CL040			B5-B14	
	35	44	0.9	40	CL040			B5-B14	
	70	27	2.7	20	CL050			B5-B14	
	56	32	2.2	25	CL050			B5-B14	
	47	37	2.4	30	CL050			B5-B14	
	35	46	1.7	40	CL050			B5-B14	
	28	54	1.3	50	CL050			B5-B14	
	23	61	1.1	60	CL050			B5-B14	
	23	71	1.4	60	CLP071/050			B14	
	19	84	1.1	75				CLP071/050	B14
	18	74	0.8	80				CL050	B5-B14
	16	98	1.3	90	CLP071/050			B14	
	28	58	3.3	50	CL070			B5	
	23	67	2.7	60	CL070			B5	
	18	82	1.9	80	CL070	B5			
	16	99	3.1	90	CLP071/070	B14			
	14	90	1.7	100		CL070	B5		
	12	122	2.2	120	CLP071/070	B14			
	9.3	143	1.8	150	CLP071/070	B14			
	7.8	159	1.4	180	CLP071/070	B14			
	5.8	189	1.1	240	CLP071/070	B14			
	4.7	211	1.0	300	CLP071/070	B14			

P_1 [kW]	n_2 [min ⁻¹]	M_2 [Nm]	sf	i				
0.37 - IEC 71								
TS7124 (1400 min ⁻¹)	47	58	4.2	30	CL070			B5
	35	73	2.9	40	CL070			B5
	28	86	2.2	50	CL070			B5
	23	98	1.8	60	CL070			B5
	23	110	2.6	60	CLP071/070			B14
	19	132	1.9	75				CLP071/070
	18	121	1.3	80	CL070			B5
	16	147	2.3	90	CLP071/070			B14
	14	134	1.2	100				CL070
	12	181	1.7	120	CLP071/070			B14
	9.3	211	1.3	150	CLP071/070			B14
	7.8	236	1.1	180	CLP071/070			B14

P_1 [kW]	n_2 [min ⁻¹]	M_2 [Nm]	sf	i				
0.55 - IEC 71								
TS7134 (1400 min ⁻¹)	280	17	2.5	5	CL040			B5/B14
	187	24	1.8	7.5	CL040			B5/B14
	140	32	1.4	10	CL040			B5/B14
	93	46	1.0	15	CL040			B5/B14
	140	32	2.6	10	CL050			B5/B14
	93	46	1.8	15				CL050
	70	59	1.2	20	CL050			B5/B14
	56	71	1.0	25	CL050			B5/B14
	47	81	1.1	30	CL050			B5/B14
	35	101	0.8	40	CL050			B5/B14
	56	75	2.4	25	CL070			B5
	35	108	1.9	40	CL070			B5
	28	128	1.5	50	CL070			B5
	23	146	1.2	60	CL070			B5
	23	163	1.7	60	CLP071/070			B14
	19	196	1.3	75				CLP071/070
	18	180	0.9	80	CL070			B5
	16	218	1.6	90	CLP071/070			B14
	12	269	1.1	120	CLP071/070			B5
9.3	314	0.9	150	CLP071/070	B14			

P_1 [kW]	n_2 [min ⁻¹]	M_2 [Nm]	sf	i				
0.37 - IEC 71								
TS7124 (1400 min ⁻¹)	280	11	3.7	5	CL040			B5/B14
	187	16	2.7	7.5	CL040			B5/B14
	140	21	2.1	10	CL040			B5/B14
	93	31	1.5	15	CL040			B5/B14
	70	39	1.0	20	CL040			B5/B14
	56	47	0.8	25	CL040			B5/B14
	47	53	0.9	30	CL040			B5/B14
	93	31	2.6	15	CL050			B5/B14
	70	40	1.8	20				CL050
	56	48	1.5	25	CL050			B5/B14
	47	55	1.6	30	CL050			B5/B14
	35	68	1.1	40	CL050			B5/B14
	28	80	0.9	50	CL050			B5/B14
	23	91	0.8	60	CL050			B5/B14
	23	105	1.0	60	CLP071/050			B14
	16	145	0.9	90				CLP071/050

P_1 [kW]	n_2 [min ⁻¹]	M_2 [Nm]	sf	i				
0.55 - IEC 80								
TS8014 (1400 min ⁻¹)	280	17	4.5	5	CL050			B5/B14
	187	24	3.2	7.5	CL050			B5/B14
	140	32	2.6	10	CL050			B5/B14
	93	46	1.8	15	CL050			B5/B14
	70	59	1.2	20	CL050			B5/B14
	56	71	1.0	25	CL050			B5/B14
	47	81	1.1	30	CL050			B5/B14
	70	62	3.3	20	CL070			B5/B14
	56	75	2.4	25				CL070
	35	108	1.9	40	CL070			B5/B14
	28	128	1.5	50	CL070			B5/B14
	23	146	1.2	60	CL070			B5/B14
	23	163	1.7	60	CLP080/070			B14
	19	196	1.3	75				CLP080/070
	18	180	0.9	80	CL070			B5/B14
	16	218	1.6	90	CLP080/070			B14
	12	269	1.1	120	CLP080/070			B14



电机 Motors	TS	
	7114 7124 7134	8014
IEC	71 B5 / B14	80 B5 / B14

CL/CLP

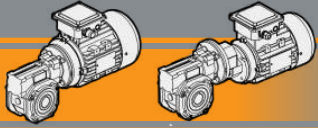

CL / CLP 蜗轮蜗杆减速电机 Wormgearmotors

技术参数

Technical data

P_1 [kW]	n_2 [min ⁻¹]	M_2 [Nm]	sf	i					P_1 [kW]	n_2 [min ⁻¹]	M_2 [Nm]	sf	i				
---------------	-------------------------------	---------------	----	---	--	--	--	--	---------------	-------------------------------	---------------	----	---	--	--	--	--

0.75 - IEC 71

TS7144 (1400 min ⁻¹)	280	23	1.8	5	CL040		B5/B14
	187	33	1.3	7.5	CL040		B5/B14
	140	43	1.0	10	CL040		B5/B14
	280	23	3.3	5	CL050		B5/B14
	187	33	2.4	7.5	CL050		B5/B14
	140	43	1.9	10	CL050		B5/B14
	93	63	1.3	15	CL050		B5/B14
	70	81	0.9	20	CL050		B5/B14
	47	111	0.8	30	CL050		B5/B14
	93	64	3.4	15	CL070		B5
	70	85	2.4	20	CL070		B5
	56	102	1.8	25	CL070		B5
	47	118	2.1	30	CL070		B5
	35	149	1.4	40	CL070		B5
	28	177	1.1	50	CL070		B5
	23	203	0.9	60	CL070		B5
	23	223	1.3	60		CLP071/070	B14
	19	267	0.9	75		CLP071/070	B14
	16	298	1.1	90		CLP071/070	B14

1.1 - IEC 80

TS8034 (1400 min ⁻¹)	280	33	2.2	5	CL050		B5/B14
	187	49	1.6	7.5	CL050		B5/B14
	140	64	1.3	10	CL050		B5/B14
	93	92	0.9	15	CL050		B5/B14
	187	50	4.0	7.5	CL070		B5/B14
	140	65	3.3	10	CL070		B5/B14
	93	95	2.3	15	CL070		B5/B14
	70	125	1.6	20	CL070		B5/B14
	56	150	1.2	25	CL070		B5/B14
	47	173	1.4	30	CL070		B5/B14
	35	219	1.0	40	CL070		B5/B14
	23	326	0.9	60		CLP080/070	B14

1.1 - IEC 90

TS90S4 (1400 min ⁻¹)	187	50	4.0	7.5	CL070		B5/B14
	140	65	3.3	10	CL070		B5/B14
	93	95	2.3	15	CL070		B5/B14
	70	125	1.6	20	CL070		B5/B14
	56	150	1.2	25	CL070		B5/B14
	47	173	1.4	30	CL070		B5/B14
	35	219	1.0	40	CL070		B5/B14
	23	326	0.9	60		CLP090/070	B5/B14

0.75 - IEC 80

TS8024 (1400 min ⁻¹)	280	23	3.3	5	CL050		B5/B14
	187	33	2.4	7.5	CL050		B5/B14
	140	43	1.9	10	CL050		B5/B14
	93	63	1.3	15	CL050		B5/B14
	70	81	0.9	20	CL050		B5/B14
	47	111	0.8	30	CL050		B5/B14
	93	64	3.4	15	CL070		B5/B14
	70	85	2.4	20	CL070		B5/B14
	56	102	1.8	25	CL070		B5/B14
	47	118	2.1	30	CL070		B5/B14
	35	149	1.4	40	CL070		B5/B14
	28	177	1.1	50	CL070		B5/B14
	23	203	0.9	60	CL070		B5/B14
	23	223	1.3	60		CLP080/070	B14
	19	267	0.9	75		CLP080/070	B14
	16	298	1.1	90		CLP080/070	B14

1.5 - IEC 90

TS90L14 (1400 min ⁻¹)	187	68	2.9	7.5	CL070		B5/B14
	140	89	2.4	10	CL070		B5/B14
	93	129	1.7	15	CL070		B5/B14
	70	170	1.2	20	CL070		B5/B14
	56	205	0.9	25	CL070		B5/B14
	47	236	1.0	30	CL070		B5/B14



电机 Motors	TS		
	7144	8024 8034	90S4 90L14
IEC	71 B5 / B14	80 B5 / B14	90 B5 / B14

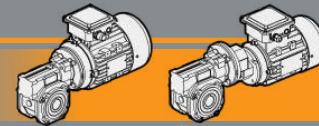

技术参数

Technical data

P_1 [kW]	n_2 [min ⁻¹]	M_2 [Nm]	sf	i				P_1 [kW]	n_2 [min ⁻¹]	M_2 [Nm]	sf	i			
---------------	-------------------------------	---------------	----	---	---	---	---	---------------	-------------------------------	---------------	----	---	---	---	---

2.2 - IEC 90

TS90L24	187	100	2.0	7.5	CL070		B5/B14
(1400 min ⁻¹)	140	131	1.7	10	CL070		B5/B14
	93	189	1.2	15	CL070		B5/B14
	70	249	0.8	20	CL070		B5/B14

3 - IEC 100

TS100L24	187	137	1.5	7.5	CL070		B5/B14
(1400 min ⁻¹)	140	178	1.2	10	CL070		B5/B14
	93	258	0.9	15	CL070		B5/B14

2.2 - IEC 100

TS100L14	187	100	2.0	7.5	CL070		B5/B14
(1400 min ⁻¹)	140	131	1.7	10	CL070		B5/B14
	93	189	1.2	15	CL070		B5/B14
	70	249	0.8	20	CL070		B5/B14

4 - IEC 112

TS112M4	187	182	1.1	7.5	CL070		B5/B14
(1400 min ⁻¹)	140	237	0.9	10	CL070		B5/B14



电机 Motors	TS		
	90L24	100L14 100L24	112M4
IEC	90 B5 / B14	100 B14 / B5	112 B14 / B5

电机技术参数

请参见专用页面:

Electrical technical data

Please see the dedicated paragraph:



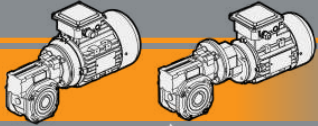

CL / CLP 蜗轮蜗杆减速电机 Wormgearmotors

IEC电机适配表

IEC Motor adapters

CL	TS					
	5624	6314 6324 6334	7114 7124 7134 7144	8024 8034	90S4 90L14 90L24	100L14
026						
030						
040						
050						
070						
CLP056/...						
CLP063/...						
CLP071/...						
CLP080/...						
CLP090/...						

备注：灰色部分指改型号有适合的电机输入。

N.B. Grey areas indicate motor inputs available on each size of unit.

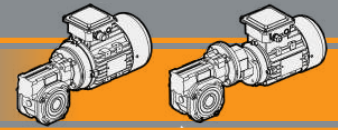

IEC电机适配表

IEC Motor adapters

	IEC	N	M	P	D	i																	
						5	7.5	10	15	20	25	30	40	50	60	80	100						
CL026	56B14	50	65	80	9																		
CL030	63B5	95	115	140	11																		
	63B14	60	75	90																			
	56B5	80	100	120	9	B	B	B	B	B	B	B	B	B	B								
	56B14	50	65	80																			
CL040	71B5	110	130	160	14																		
	71B14	70	85	105																			
	63B5	95	115	140	11	B	B	B	B	B	B	B	B										
	63B14	60	75	90																			
	56B5	80	100	120	9	BS	BS	BS	BS	BS	BS	BS	BS	BS	B	B	B	B					
	56B14	50	65	80																			
CL050	80B5	130	165	200	19																		
	80B14	80	100	120																			
	71B5	110	130	160	14	B	B	B	B	B	B	B											
	71B14	70	85	105																			
	63B5	95	115	140	11	BS	BS	BS	BS	BS	BS	BS	BS	B	B	B	B						
	63B14	60	75	90																			
CL070	100/112B5	180	215	250	28																		
	100/112B14	110	130	160																			
	90B5	130	165	200	24		B	B	B	B													
	90B14	95	115	140																			
	80B5	130	165	200	19		BS	BS	BS	BS	B	B	B										
	80B14	80	100	120																			
	71B5	110	130	160	14						BS	BS	BS	B	B	B	B						

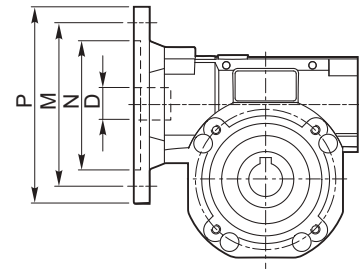

注释: Nema法兰可选
Note: Nema flange available on demand

CL/CLP

CMP	IEC	N	M	P	D	i (i ₁ x i ₂)								
						60 (3x20)	75 (3x25)	90 (3x30)	120 (3x40)	150 (3x50)	180 (3x60)	240 (3x80)	300 (3x100)	
056/030	56 B14	50	65	80	9									
056/040						B	B	B	B					
063/040	63 B14	60	75	90	11									
063/050						B	B	B						
071/050	71 B14	70	85	105	14									
071/070						BS	B	B	B					
080/070	80 B14	80	100	120	19	B								
090/070	90 B14 90 B5	95 130	115 165	140 200	24	B								

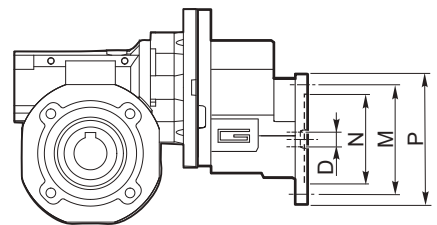

备注:

灰色部分指该型号有适合的电机输入。

N.B. Grey areas indicate motor inputs available on each size of unit.

B/BS = 金属轴套

B/BS = Metal shaft sleeve

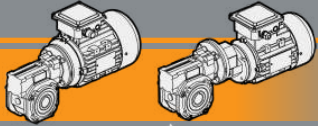

尺寸参数

Dimensions

CL 026 U

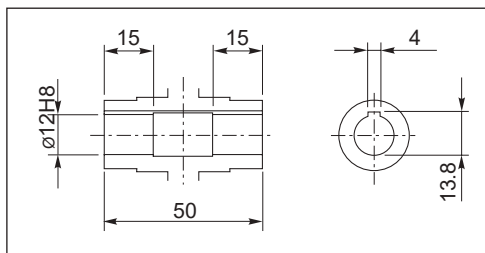
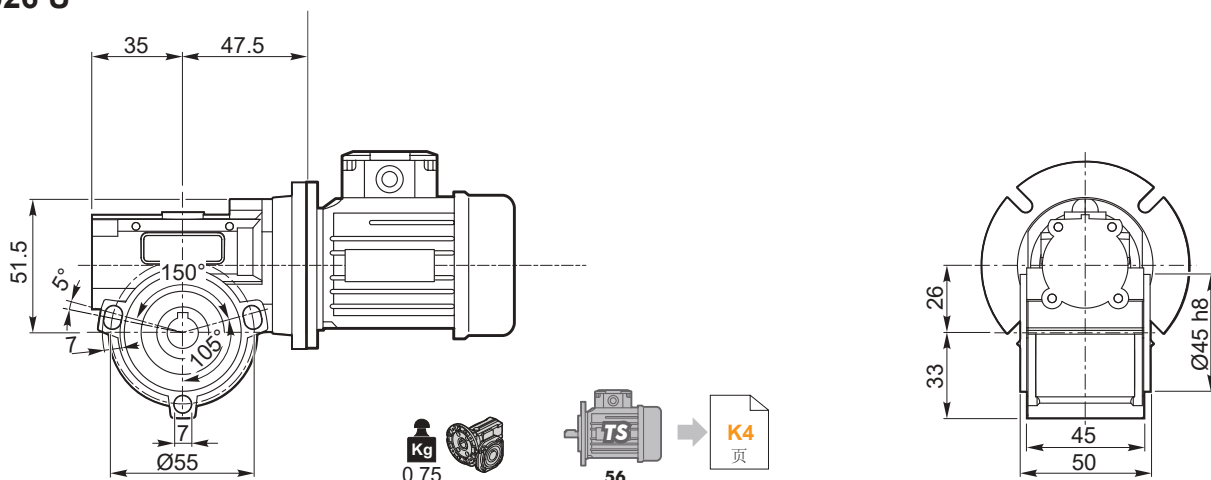

空心输出轴 / Hollow output shaft

CLIS 026 ..

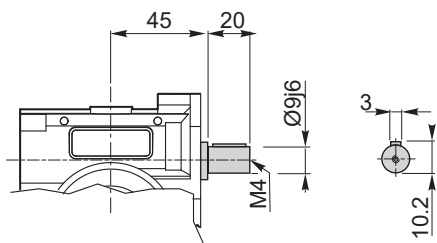

CL 026 F

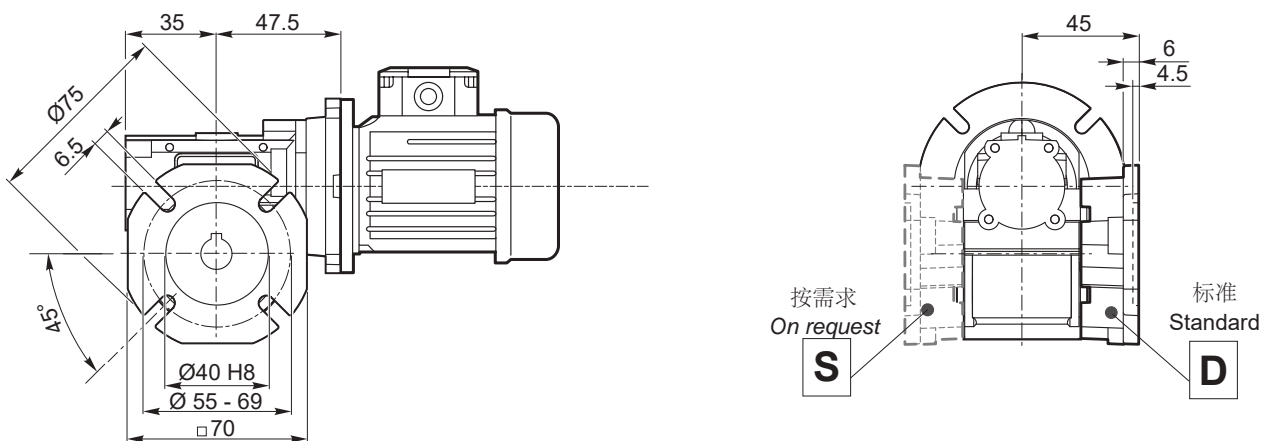

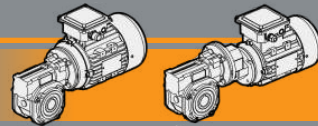

尺寸参数

Dimensions

CL 030 U

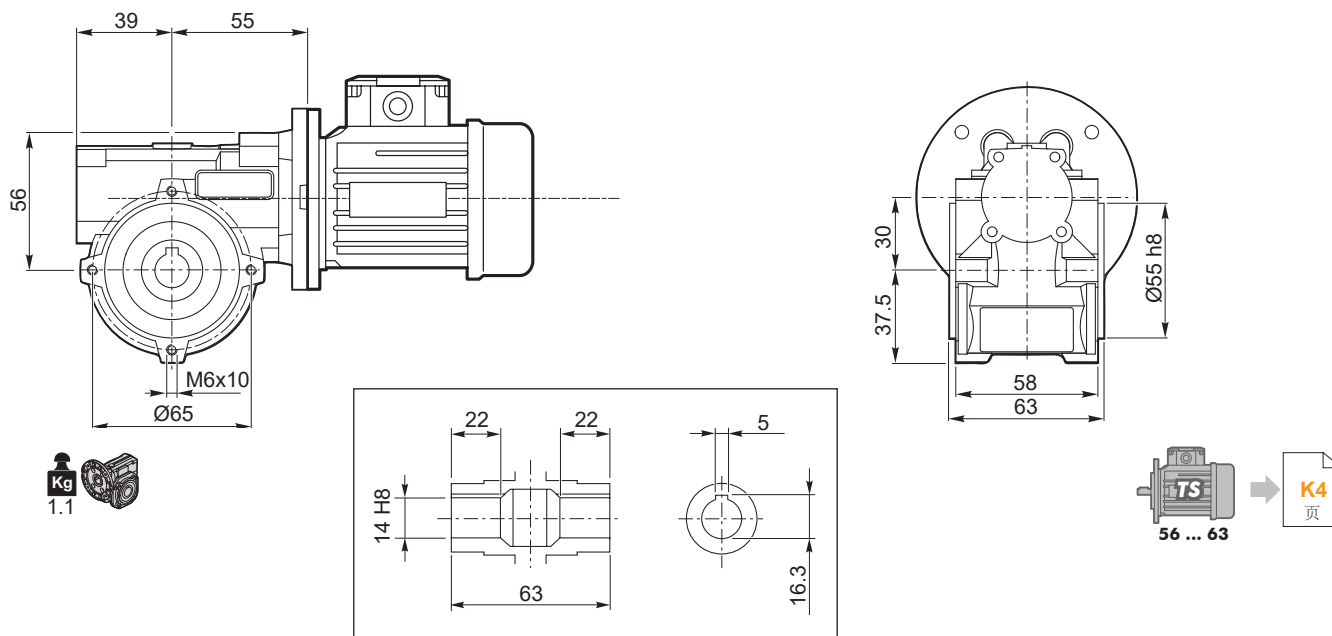

空心输出轴 / Hollow output shaft

CLIS 030 ..

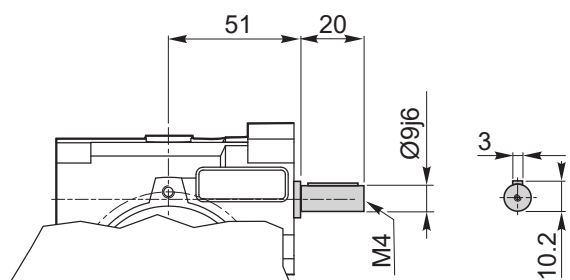

CLP 050/030...
CLP 056/030...

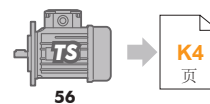
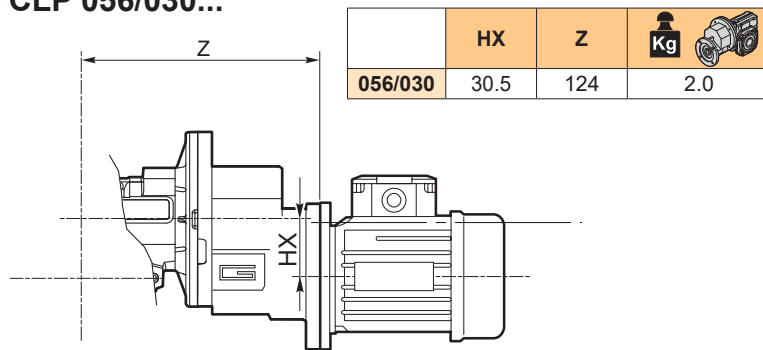

CL 030 F

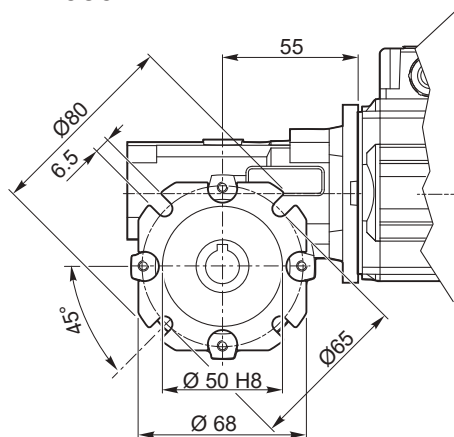

CLP../030 F

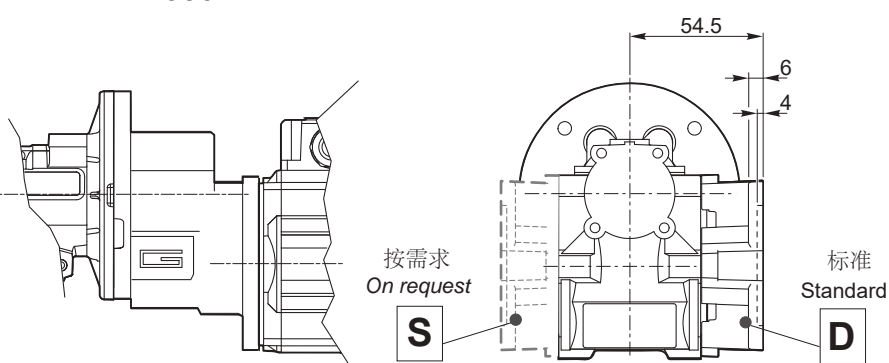

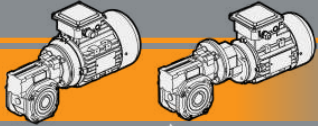

尺寸参数

Dimensions

CL 040 U

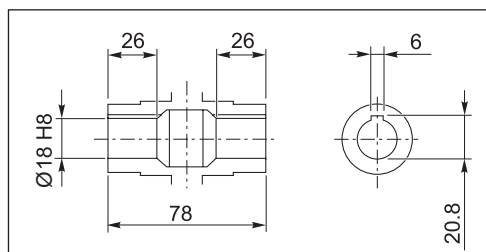
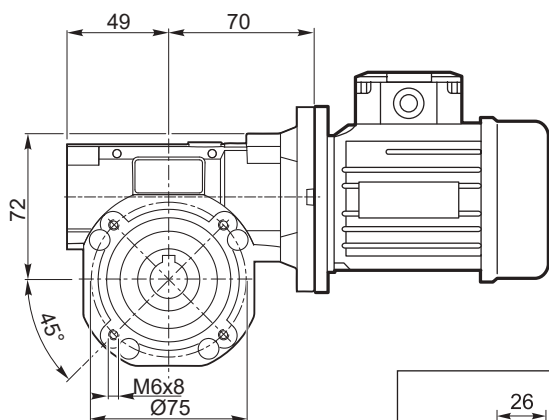

空心输出轴 / Hollow output shaft

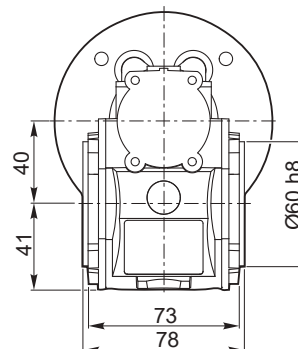

CLIS 040 ..

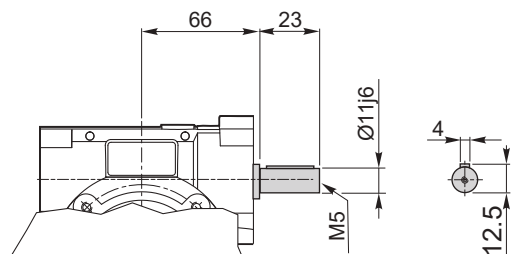

CLP .../040 ...U

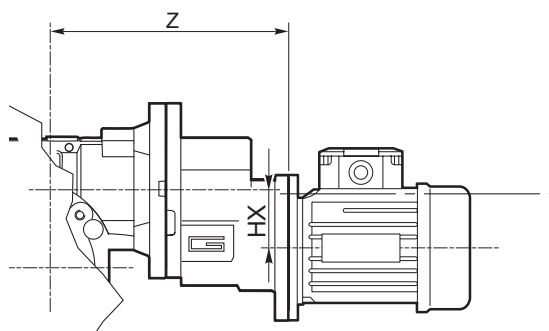

	HX	Z	Kg 
056/040	30.5	139	3.0
063/040	30.5	142	3.1



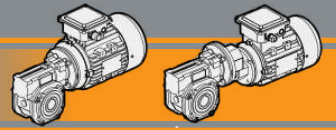

尺寸参数

Dimensions

CL 040 F

CLP../040 F

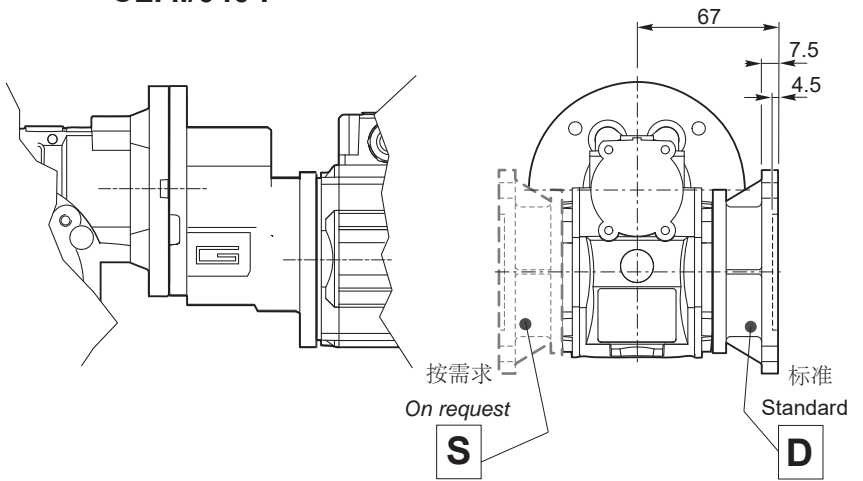
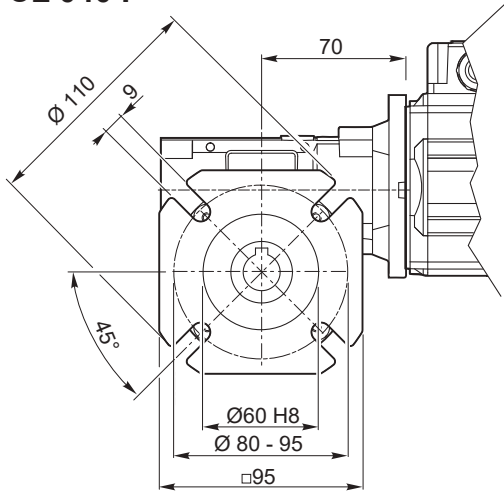

CL 040 FB

CLP../040 FB

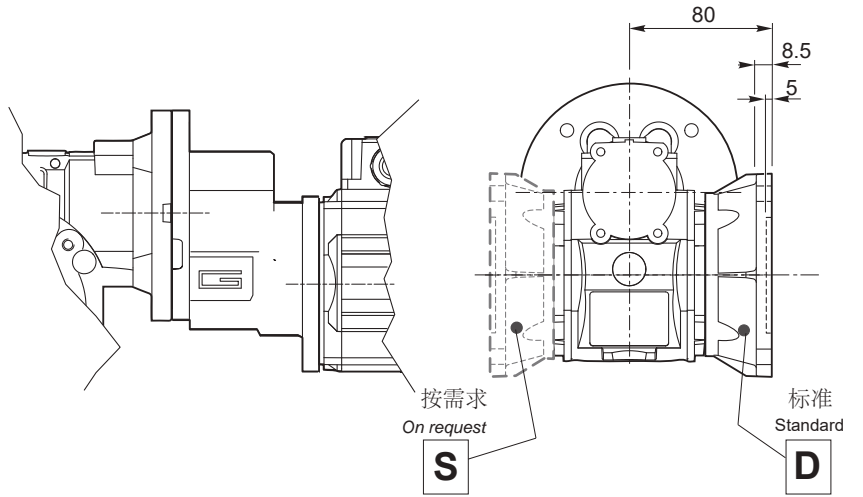
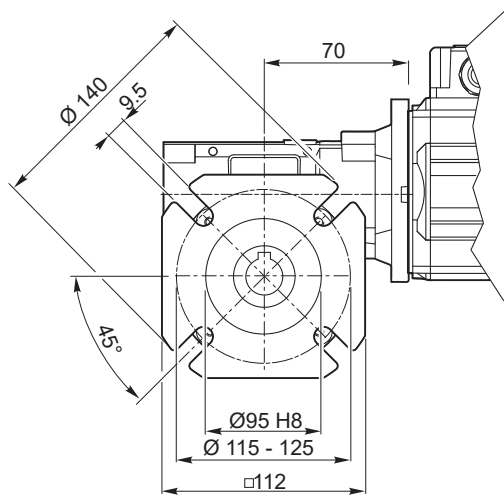

CL 040 FL

CLP../040 FL

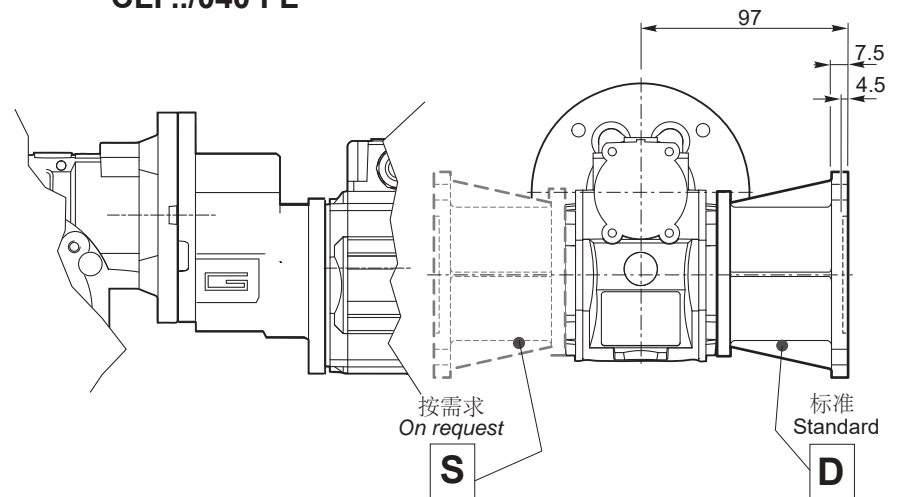
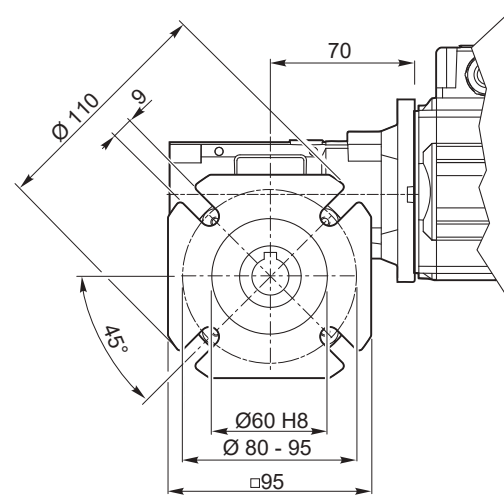

CL/CLP

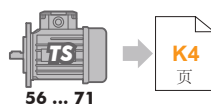

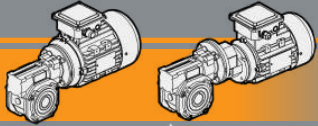

CL / CLP 蜗轮蜗杆减速电机 Wormgearmotors

尺寸参数

Dimensions

CL 050 U

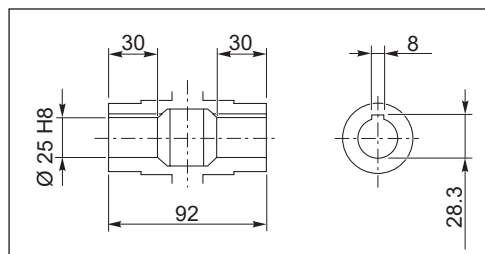
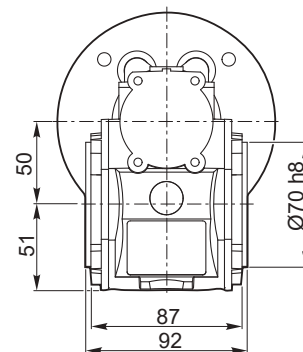
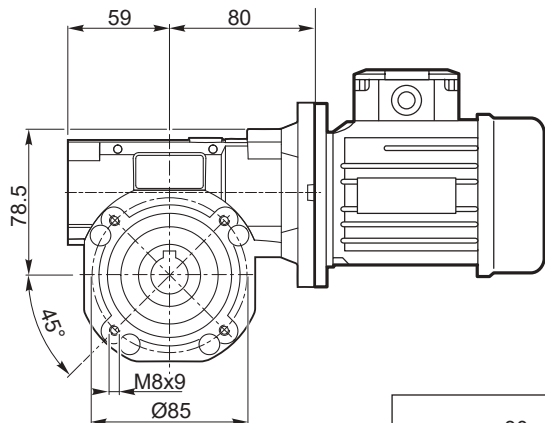

空心输出轴 / Hollow output shaft

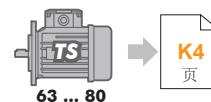

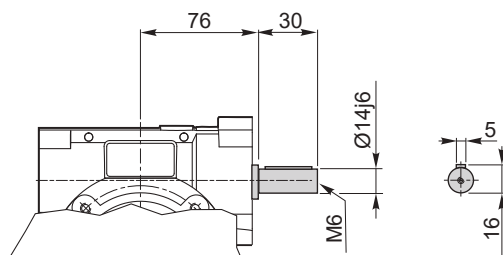

CLIS 050 ..

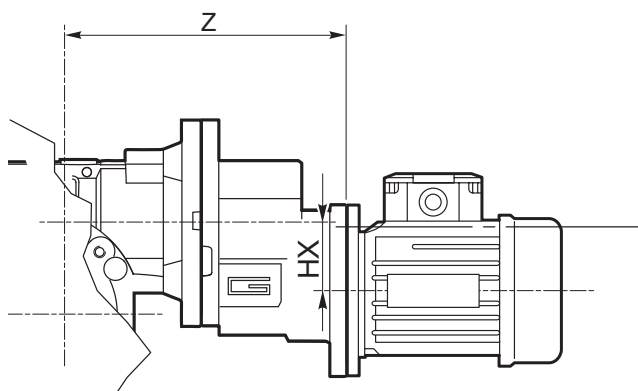

CLP .../050 ...U



	HX	Z	 Kg 
063/050	30.5	152	4.3
071/050	41	169	5.3

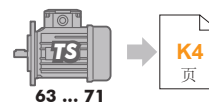

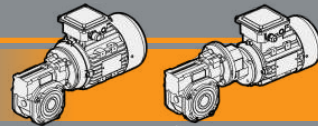

尺寸参数

Dimensions

CL 050 F

CLP../050 F

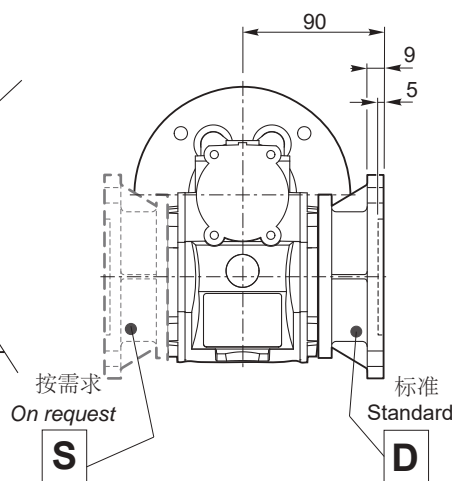
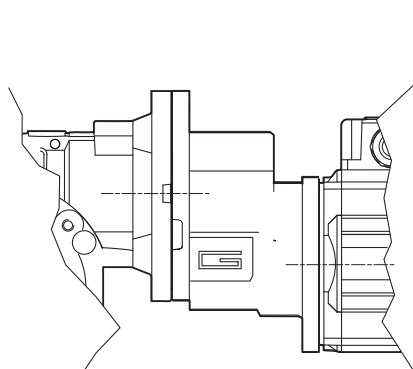
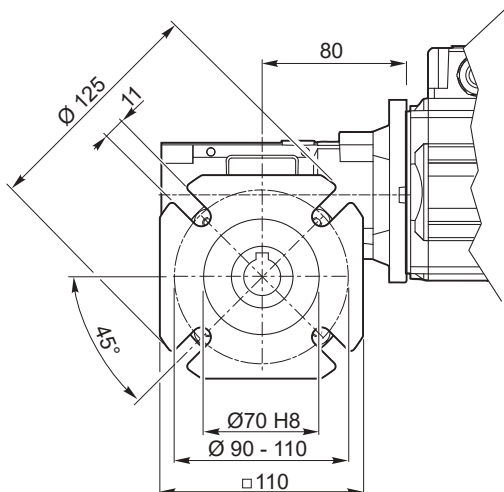

CL 050 FB

CLP../050 FB

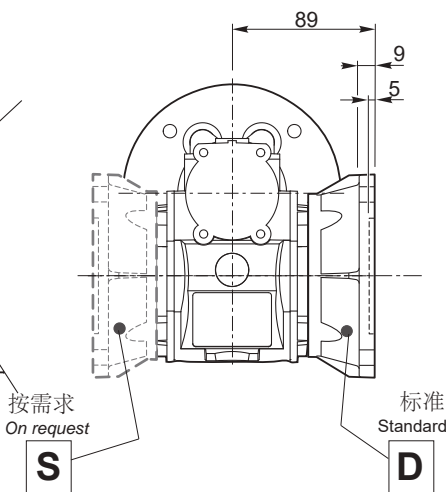
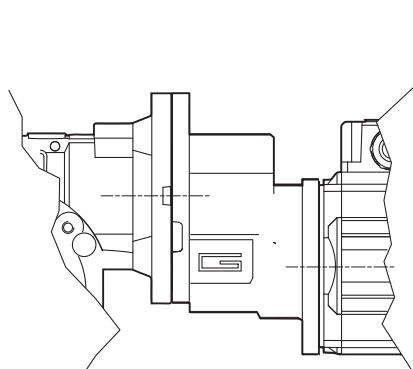
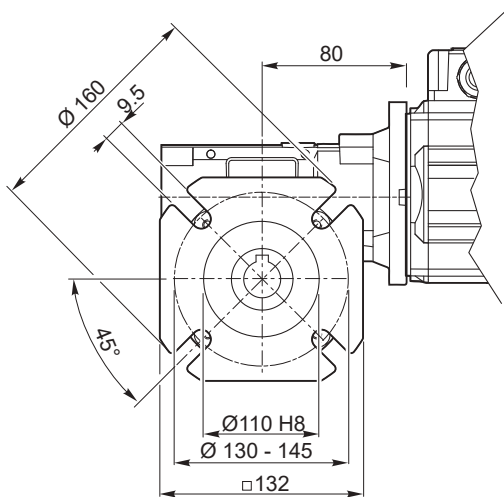

CL 050 FL

CLP../050 FL

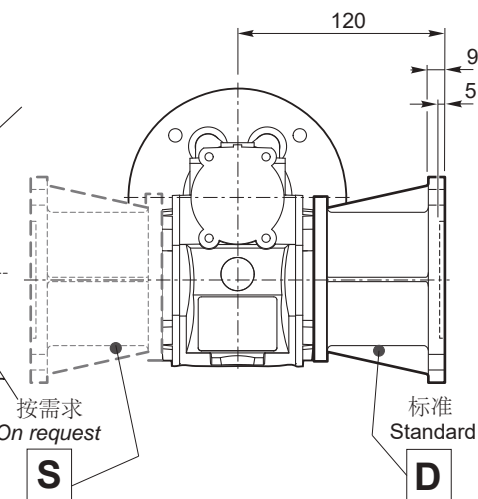
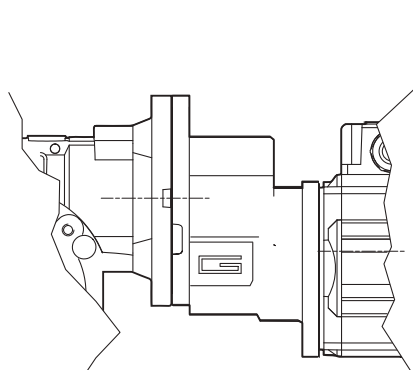
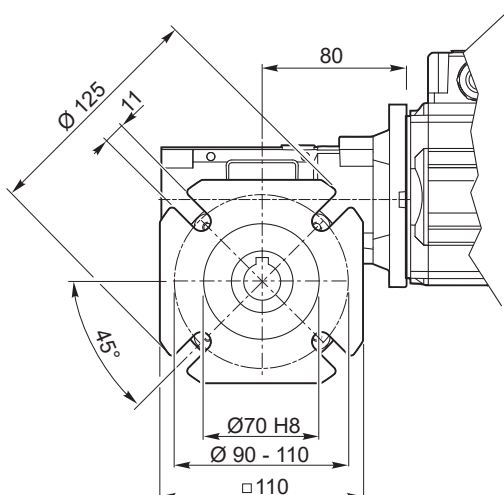

CL/CLP

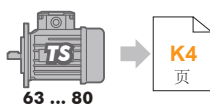

63 ... 80

K4
页

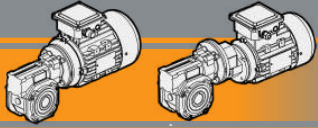

尺寸参数

Dimensions

CL 070 U

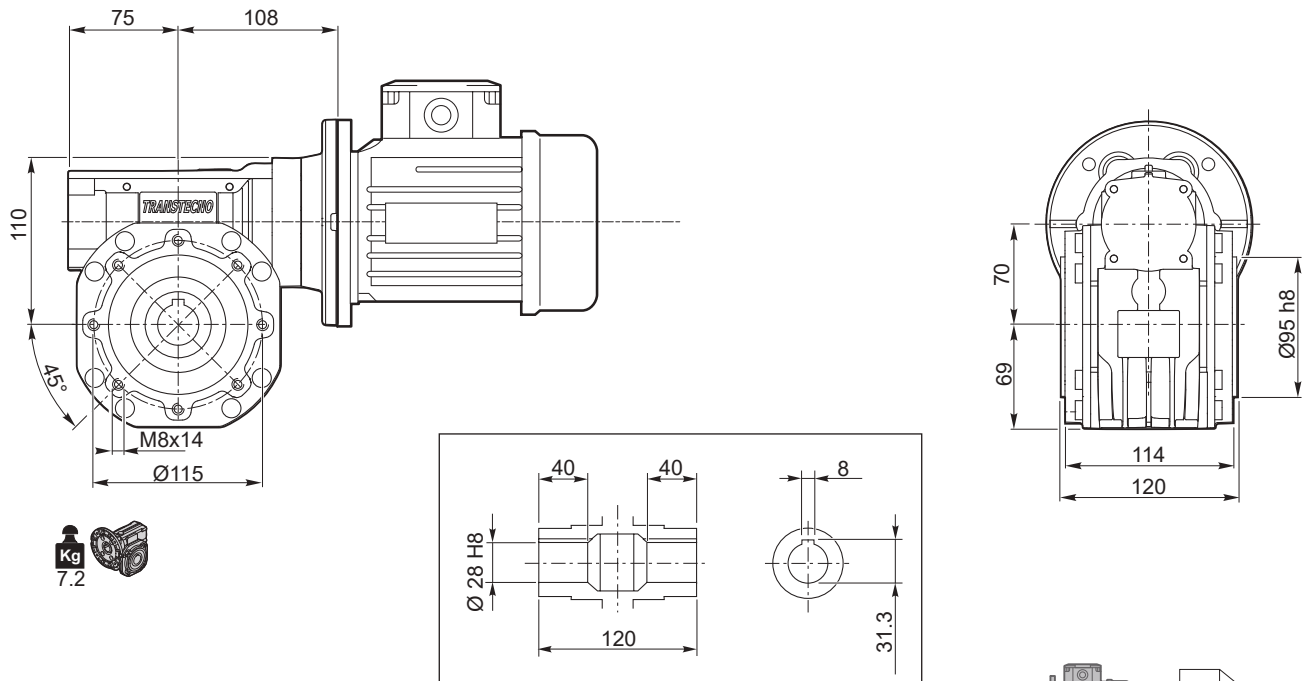

空心输出轴 / Hollow output shaft

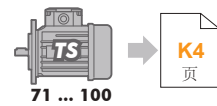

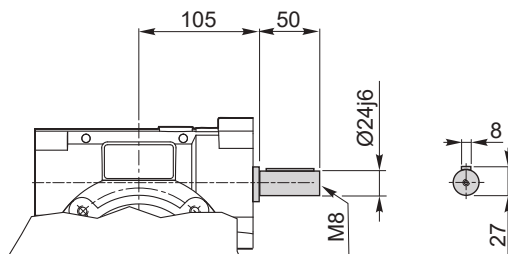

CLIS 070...

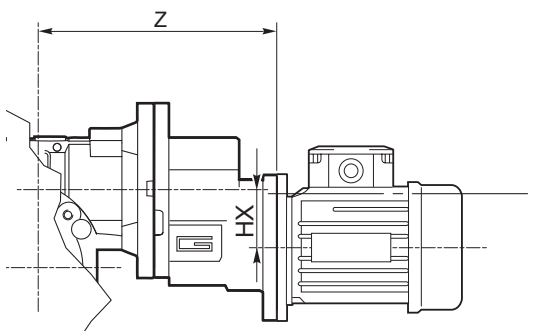

CLP .../070 ...U



	HX	Z	 Kg 
071/070	41	197	8.7
080/070	41	208	9.5
090/070	36.5	262	10.2

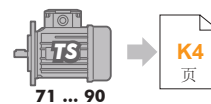

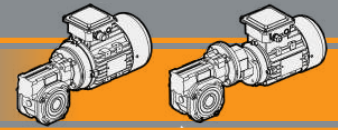

尺寸参数

Dimensions

CL 070 F

CLP../070 F

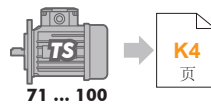
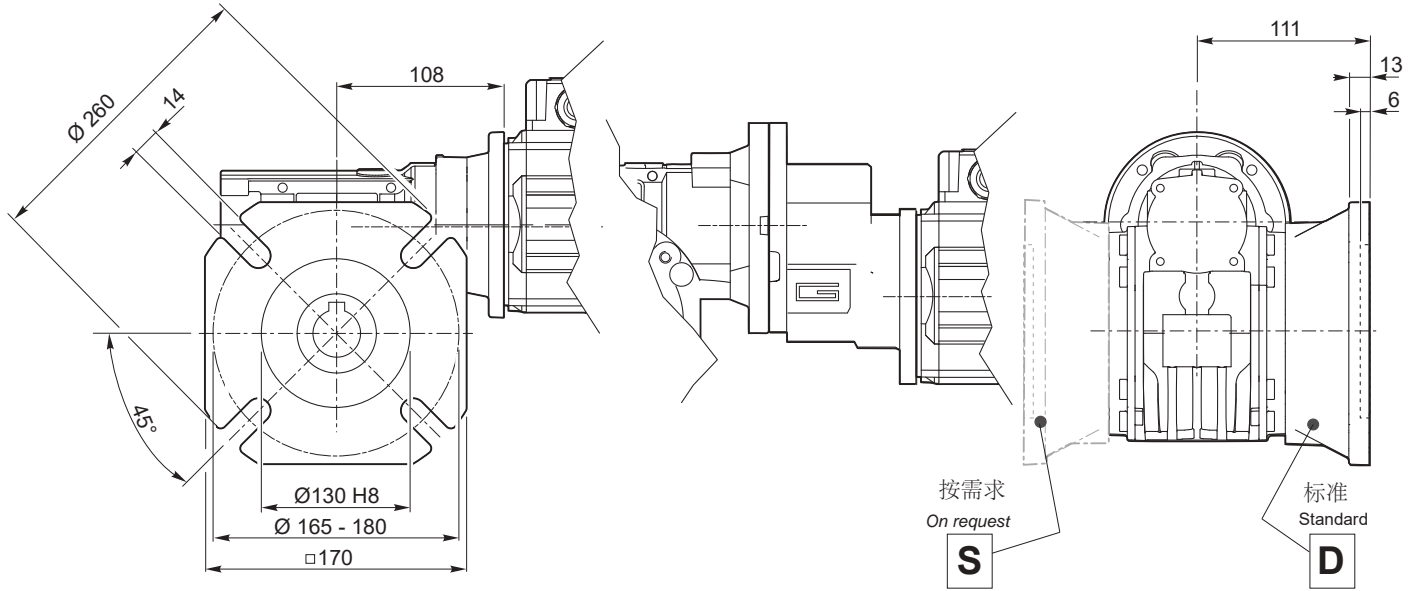

附件

Accessories

单向和双向输出轴

Single and double output shaft

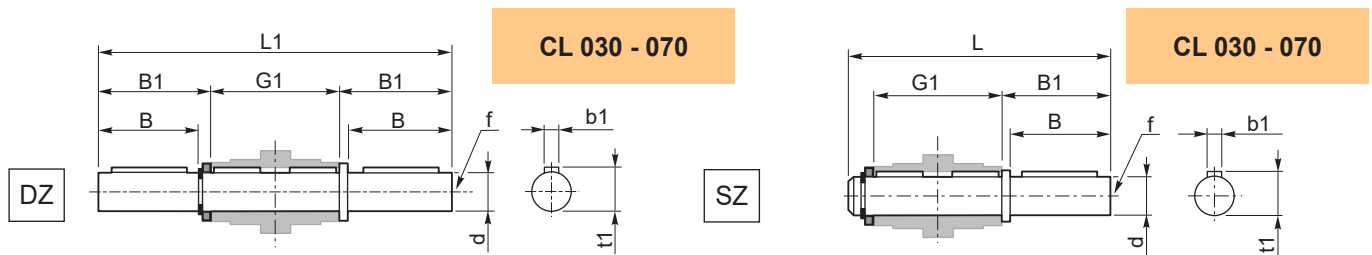

CL	CLP	d _{h7}	B	B1	G1	L	L1	f	b1	t1
030	056/030	14	30	32.5	63	102	128	M6	5	16
040	056/040 063/040	18	40	43	78	128	164	M6	6	20.5
050	063/050 071/050	25	50	53.5	92	153	199	M10	8	28
070	071/070 080/070 090/070	28	60	63.5	120	192	247	M10	8	31

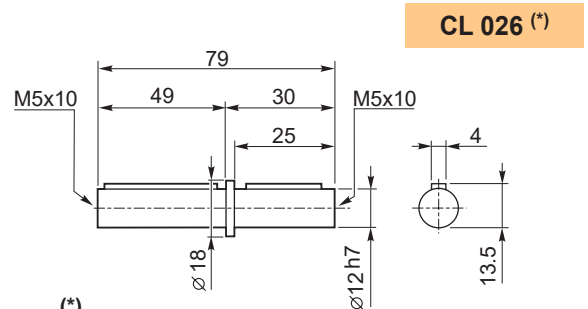

(*)
注释: 只适用于空心输出轴 Ø12
Note: available for output hollow shaft Ø12 only

CL/CLP

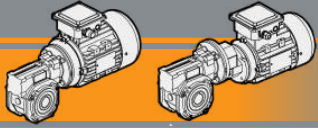

附件

Accessories

KIT - 扭力臂

KIT - Torque arm

CL	CLP	K1	G	KG	KH	R
030	056/030	85	14	23	8	15
040	056/040 063/040	100	14	31	10	18
050	063/050 071/050	100	14	38	10	18
070	071/070 080/070 090/070	200	25	46.5	20	30

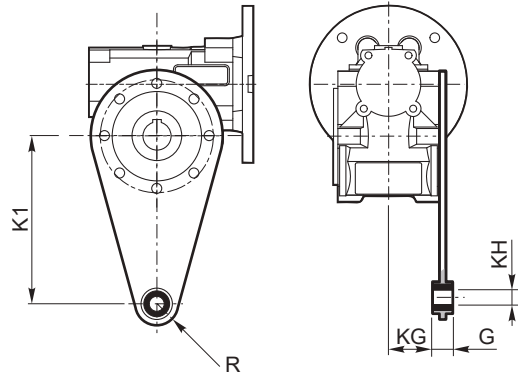

可选项

Options

VS - 加强输入轴 / Extended input shaft

CL	CLP	A	B	D ₁ j6	E	F	G
030	056/030	45	20	9	M4	3	10.2
040	056/040 063/040	53	23	11	M5	4	12.5
050	063/050 071/050	64	30	14	M6	5	16
070	071/070 080/070 090/070	84	40	19	M6	6	21.5

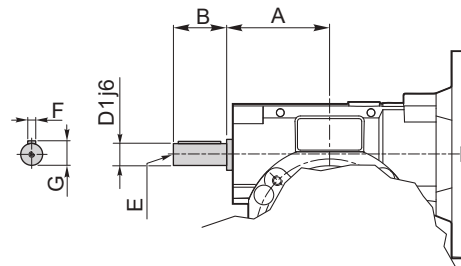

按要求定制
Built on request

SC - 防尘盖 / Safety Cover

CL	CLP	M
030	056/030	47
040	056/040 063/040	54.5
050	063/050 071/050	62.5
070	071/070 080/070 090/070	75

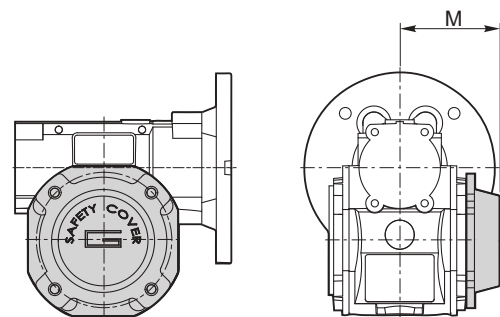



TRANSTECNO SRL HEADQUARTERS

Company subject to the management
and coordination of INTERPUMP GROUP SPA
Via Caduti di Sabbiuno, 11/D-E
40011 Anzola dell'Emilia (BO)
ITALY
T+39 051 64 25 811
F +39 051 73 49 43
sales@transtecno.com
www.transtecno.com

TRANSTECNO®

the modular gearmotor

MEMBER OF INTERPUMP GROUP

CATALUAC122 HTC



**HANGZHOU TRANSTECNO POWER
TRANSMISSIONS CO LTD**
No.4 Xiuyan Road Fengdu Industry Zone
Pingyao Town Yuhang District
Hangzhou City, Zhejiang Province
311115 – CHINA
T +86 571 86 92 02 60
info-china@transtecno.cn
www.transtecno.cn



MA TRANSTECNO S.A.P.I. DE C.V.
Av. Mundial # 176, Parque Industrial
JM Apodaca, Nuevo León,
C.P. 66600 - MÉXICO
T +52 8113340920
info@transtecno.com.mx
www.transtecno.com.mx



**TRANSTECNO IBÉRICA
THE MODULAR GEARMOTOR, S.A.**
Carrer de la Ciència, 45
08840 Viladecans (Barcelona) - SPAIN
T +34 931 598 950
info@transtecno.es
www.transtecno.es



TRANSTECNO B.V.
Siliciumweg 32
3812 SX Amersfoort - NETHERLANDS
T +31(0) 33 45 19 505
info@transtecno.nl
www.transtecno.nl



TRANSTECNO AANDRIJFTECHNIEK B.V.
Siliciumweg 32
3812 SX Amersfoort - NETHERLANDS
T +31 (0) 33 20 4 7 006
info@transtecnoaandrijftechnik.nl
www.transtecnoaandrijftechnik.nl



TRANSTECNO USA
8 Creek Parkway,
Boothwyn PA 19061-8136 - UNITED STATES
T + 1 (610) 4970154

TRANSTECNO USA – WEST COAST BRANCH
14561 Fryelands Blvd SE
Monroe, WA 98272 - UNITED STATES
T +1 360-863-1300
usaoffice@transtecno.com
www.transtecno.com



TRANSTECNO CANADA
51 B Caldari Road Unit 10
Vaughan, ON L4K 4G3 - CANADA
T +1 905 761 0762
canadaoffice@transtecno.com
www.transtecno.com



TRANSTECNO CHILE-PERU
Av. Los Libertadores 41
Parque Industrial - Los Libertadores 16.500
Santiago, Colina - CHILE
T +56 2 29633870

Carretera Panamericana Sur KM 29.5,
Interior I-3, Z.I. Lurin - PERU
T +51 1 3546259 / + 51 1 3434231
chileoffice@transtecno.com
www.transtecno.com



TRANSTECNO INDIA
#6A, Sipcot Industrial complex, Phase-1,Elasagiri Road
Hosur – 635126 Tamilnadu - INDIA
T +91 4344 274434
M +91 81443 88800

TRANSTECNO INDIA – NORTH BRANCH
Plot No: 3 A, Sector 2, IIE, Sidcul, Pantnagar
U.S. Nagar, Uttarakhand – 263153 - INDIA
indiaoffice@transtecno.com
www.transtecno.com



TRANSTECNO BRAZIL
Rua Gilberto de Zorzi, 525 Forqueta - CEP. 95115-730
CX Postal 3544 Caxias do Sul RS – BRAZIL

TRANSTECNO BRAZIL – SÃO PAULO BRANCH
R. Mafalda Barnabe Soliane, 314 – CEP. 13347-610
Indaiatuba, São Paulo - BRAZIL
T +55 19 3437 2520

TRANSTECNO BRAZIL – PORTO ALEGRE BRANCH
Rua Dr. Freire Alemão 155 / 402 - CEP. 90450-060
Auxiliadora Porto Alegre RS - BRAZIL
T +55 51 3251 5447
M +55 51 811 45 962
braziloffice@transtecno.com
www.transtecno.com.br



INTERPUMP ANTRIEBSTECHNIK - TRANSTECNO
Vertriebsbüro Stuttgart - GERMANY
T +49 (0)171 4781909
germanoffice@transtecno.com
www.transtecno.com



SALES OFFICE OCEANIA
Unit 5, 12 Nyholt Drive, Yatala 4207
Queensland - AUSTRALIA
T +61 07 3800 0103
M +61 04 38060997

UNIT 9 , 94 Boundary Rd, Sunshine West 3020
Victoria - AUSTRALIA
T +61 9312 4722
oceaniaoffice@transtecno.com
www.transtecno.com.au



SALES OFFICE SOUTH KOREA
772-41. Bongdong-ro, Bongdong-eup, Wanju-goon
Chonbuk, 55313
SOUTH KOREA
T +82 70 8867 8897
M +82 10 5094 2107
koreaoffice@transtecno.com
www.transtecno.com

www.transtecno.com